



RECORD ONLY SUBMITTAL PACKAGE

Prepared For:

Central States Diesel Generators
1901 South Prairie
Waukesha, Wisconsin 53189

THIS SUBMITTAL IS BEING PREPARED FOR RECORD PURPOSES ONLY

The information presented in this submittal package has been approved

and is provided for record purposes only.

Date: 12/3/2025



Serving Cummins Customers
cummins.com/sales-and-service



DISCLAIMER



Serving Cummins Customers

Cummins power solutions are supported by the largest and best-trained worldwide certified sales/distributor network in the industry. This network will help you select and install the critical power solution to meet the requirements of your specific application. This same network provides experts with advanced technology to make your life easier while providing a seamless support experience.

IMPORTANT: *The critical power solution information and specifications included in this pdf can be used by the site contractor(s) and/or engineer(s) to assist with planning for and accomplishing the overall power solution installation. Please forward this document to the appropriate personnel, as necessary.*

It is the obligation of the electrical contractor and reviewing engineer to determine that the item quantities and accuracy of this submittal is correct as required for the job. Any inaccuracies or deviations must be addressed with Cummins Inc. before release to manufacturing. Any releases of material to manufacturing by the above parties constitute an acceptance of the accuracy of the submittal. Any changes after release will be viewed as a change order, subject to pricing changes. Please take the time to review this package for accuracy to prevent any after-shipment problems that could cause delay in energization.

Cummins certifies that these drawings, material lists, specification and datasheets have been checked prior to submittal and they:

- accurately depict the proposed equipment*
- provide current information to the date of the submittal and*
- present true and accurate equipment information.*

This Approval Drawing Package is submitted as our interpretation of the project requirements and/or the specifications for this job. Please note that issuance of these submittals shall not be deemed or interpreted as performance nor acceptance of your purchase order terms and conditions.

For questions or comments regarding this submittal, please contact the Cummins Project Manager listed on the title page.

TABLE OF CONTENTS



Section 1 - Project Information

Project Bill of Material

Section 2 - Generator Specification Sheets

Generator Specification Sheet

Generator Data Sheet

PowerCommand Control (PCC) Specification Sheet

Fuel Tank Specification Sheet

Exhaust Emission Compliance Statement

Exhaust Emission Data Sheet

Sound Data Sheet

Prototype Test Summary Report

Cooling System Data Sheet

Alternator Data Sheet

Section 3 - Generator Accessories

Battery Charger Specification Sheet

Circuit Breaker Data Sheet

Green Sound Level 2 Intake Baffle (Ship Loose)

Kit, Enclosure SL2 Duct (A062H155)

Section 4 - Generator Drawings and Interconnects

Generator Outline Drawing

Generator Options Outline Drawing

Circuit Breaker Outline Drawing

Enclosure Outline Drawing

Fuel Tank Outline Drawing

Foundation Outline Drawing

AC Interconnection Wiring Diagram

Section 5 - Warranty

Generator Warranty Statement

SECTION 1

Project Information



Bill of Material

Feature Code	Description	Qty
C200D6D C200 D6D Install-US-Stat A331-2 L169-2 L090-2 L193-2 B184-2 R098-2 B946-2 F217-2 P176-2 F252-2 F179-2 C319-2 4110 C127-2 C310-2 C318-2 H609-2 H700-2 K796-2 H536-2 KV03-2 KY06-2 4090 4100 KB72-2 A366-2 A422-2 D041-2 A333-2 BB89-2 E125-2 H527-2 E089-2 H669-2 E153-2 H706-2 L028-2 L050-2 A322-2 F065-2 H268-2 L260-2	C200D6D, Diesel Genset, 60Hz, 200kW C200D6D, Diesel Genset, 60Hz, 200kW U.S. EPA, Stationary Emergency Application Duty Rating - Standby Power (ESP) Emission Certification, EPA, Tier 3, NSPS CI Stationary Emergency Listing - UL 2200 NFPA 110 Type 10 Level 1 Capable Exciter/Regulator - Permanent Magnet Generator, 3 Phase Sensor Voltage - 120/208, 3 Phase, Wye, 4 Wire Alternator - 60Hz, 12L, 208/120V, 120C, 40C Ambient Aluminum Sound Attenuated Level 2 Enclosure, with Exhaust System Enclosure Color - Green, Aluminum Enclosure - Wind Load 180 MPH, ASCE7-10 Skidbase - Housing Ready UL142 Sub Base Dual Wall Basic, Diesel Fuel Tank, 24 Hour Minimum Fuel System Alarm - None Fuel Water Separator Low Fuel Level Switch, 40% Switch - Fuel Tank, Rupture Basin Control Mounting - Left Facing PowerCommand 1.1 Controller Stop Switch - Emergency Control Display Language - English Load Connection - Single Circuit Breaker, Location A, 200A - 600A, 3P, LSI, 600 Volts AC, 100%, UL Circuit Breaker or Terminal Box (Position B) - None Circuit Breaker or Terminal Box (Position C) - None Circuit Breaker or Entrance Box - Bottom Entry,Right Side Engine Governor - Electronic, Isochronous Engine Starter - 12 Volt DC Motor Engine Air Cleaner - Normal Duty Battery Charging Alternator Battery Charger - 6 Amp, Regulated Engine Cooling - Radiator, High Ambient Air Temperature, Ship Fitted Warning - Low Coolant Level Extension - Coolant Drain Engine Coolant - 50% Antifreeze, 50% Water Mixture Coolant Heater,Cold Ambient Engine Oil Genset Warranty - 2 Years Base Literature - English Packing - Skid, Poly Bag Battery Rack Extension - Oil Drain Green Sound Level 2 Intake Baffle - Ship Loose	1

A062H155-FRD	Kit, Enclosure (SL2 Duct)	
--------------	---------------------------	--

NOTES:

Proposal is for equipment only, offloading, rigging, and installation by others.
Fuel and permits, unless listed above, is not included.
Cummins Standard Start-up and testing is included. Additional tests, such as NETA testing, if required, is by others
Coordination Study not provided.

SECTION 2

Generator Specifications





Diesel generator set

QSB7 series engine

125-200 kW @ 60 Hz

EPA Tier 3 emissions



Description

Cummins® generator sets are fully integrated power generation systems providing optimum performance, reliability and versatility for stationary Standby applications.

Features

Heavy duty engine - Rugged 4-cycle industrial diesel delivers reliable power and fast response to load changes.

Alternator - Several alternator sizes offer selectable motor starting capability with low reactance 2/3 pitch windings, low waveform distortion with non-linear loads and fault clearing short-circuit capability.

Control system - The PowerCommand® 1.1 electronic control is standard equipment and provides total generator set system integration including automatic remote starting/stopping, precise frequency and voltage regulation, alarm and status message display, output metering, auto-shutdown at fault detection and NFPA 110 Level 1 compliance.

Cooling system - Standard cooling package provides reliable running at up to 50 °C (122 °F) ambient temperature.

Enclosures - The aesthetically appealing enclosure incorporates special designs that deliver one of the quietest generators of its kind. Aluminium material plus durable powder coat paint provides the best anti-corrosion performance. The generator set enclosure has been evaluated to withstand 180 MPH wind loads in accordance with ASCE7 -10. The design has hinged doors to provide easy access for service and maintenance.

Fuel tanks - Dual wall sub-base fuel tanks are offered as optional features, providing economical and flexible solutions to meet extensive code requirements on diesel fuel tanks.

NFPA - The generator set accepts full rated load in a single step in accordance with NFPA 110 for Level 1 systems.

Warranty and service - Backed by a comprehensive warranty and worldwide distributor network.

Model	Standby 60 Hz		Prime 60 Hz		Data sheets
	kW	kVA	kW	kVA	
C125D6D	125	156	113	141	NAD-6371-EN
C150D6D	150	188	135	169	NAD-6372-EN
C175D6D	175	219	158	197	NAD-6373-EN
C200D6D	200	250	180	225	NAD-6374-EN

Generator set specifications

Governor regulation class	ISO8528 Part 1 Class G3
Voltage regulation, no load to full load	± 1.0%
Random voltage variation	± 1.0%
Frequency regulation	isochronous
Random frequency variation	± 0.50%
Radio frequency emissions compliance	FCC code title 47 part 15 class A and B

Engine specifications

Design	Turbocharged and charge air cooled
Bore	107 mm (4.21 in.)
Stroke	124 mm (4.88 in.)
Displacement	6.7 L (408 in ³)
Cylinder block	Cast iron, in-line 6 cylinder
Battery capacity	2 x 850 amps per battery at ambient temperature of 0 °C (32 °F)
Battery charging alternator	100 amps
Starting voltage	2 x 12 volt in parallel, negative ground
Lube oil filter type(s)	Spin-on with relief valve
Standard cooling system	High ambient radiator
Rated speed	1800 rpm

Alternator specifications

Design	Brushless, 4 pole, drip proof, revolving field
Stator	2/3 pitch
Rotor	Direct coupled, flexible disc
Insulation system	Class H per NEMA MG1-1.65
Standard temperature rise	120 °C (248 °F) Standby
Exciter type	Torque match (shunt) with PMG as option
Alternator cooling	Direct drive centrifugal blower
AC waveform Total Harmonic Distortion (THDV)	< 5% no load to full linear load, < 3% for any single harmonic
Telephone Influence Factor (TIF)	< 50 per NEMA MG1-22.43
Telephone Harmonic Factor (THF)	< 3%

Available voltages

1-phase		3-phase			
• 120/240	• 120/208	• 120/240	• 277/480	• 347/600	• 127/220

Generator set options

Fuel system

- **Basic fuel tanks**
- Regional fuel tanks

Engine

- **Engine air cleaner – normal** or heavy duty
- Shut down – low oil pressure
- **Extension – oil drain**
- Engine oil heater

Alternator

- **120 °C temperature rise alternator**
- 105 °C temperature rise alternator
- **PMG excitation**
- Alternator heater, 120 V
- Reconnectable full 1 phase output alternator upto 175 kW

Control

- AC output analog meters
- **Stop switch – emergency**
- Auxiliary output relays (2)
- Auxiliary configurable signal inputs (8) and relay outputs (8)

Electrical

- **One, two or three circuit breaker configurations**
- 80% rated circuit breakers
- 80% or **100% rated LSI circuit breakers**
- **Battery charger**

Enclosure

- **Aluminium enclosure** Sound Level 1 or **Level 2, green color**
- Aluminium weather protective enclosure with muffler installed, green color

Cooling system

- Shutdown – low coolant level
- **Warning – low coolant level**
- **Extension – coolant drain**
- **Coolant heater options:**
 - <4 °C (40 °F) – cold weather
 - <-18 °C (0 °F) – extreme cold

Exhaust system

- Exhaust connector NPT
- Exhaust muffler mounted

Generator set application

- Base barrier – elevated genset
- Radiator outlet duct adapter

Warranty

- **Base warranty – 2 year/1000 hours, Standby**
- Base warranty – 1 year/unlimited hours, Prime
- 3 & 5 year Standby warranty options

Generator set accessories

- **Coolant heater**
- Battery heater kit
- Engine oil heater
- Remote control displays
- Auxiliary output relays (2)
- Auxiliary configurable signal inputs (8) and relay outputs (8)
- Annunciator – RS485
- Audible alarm
- Remote monitoring device – PowerCommand 500/550
- **Battery charger** – stand-alone, 12 V
- **Circuit breakers**
- Enclosure Sound Level 1 to Sound Level 2 upgrade kit
- Base barrier – elevated generator set
- Mufflers – industrial, residential or critical
- **Alternator PMG excitation**
- Alternator heater
- Improved PC1.1 display readability
- Top conduit entry access

Control system PowerCommand 1.1



PowerCommand control is an integrated generator set control system providing voltage regulation, engine protection, operator interface and isochronous governing (optional). Major features include:

- Battery monitoring and testing features and smart starting control system.
- Standard PCCNet interface to devices such as remote annunciator for NFPA 110 applications.
- Control boards potted for environmental protection.
- Control suitable for operation in ambient temperatures from -40 °C to +70 °C (-40 °F to +158 °F) and altitudes to 5000 meters (13,000 feet).
- Prototype tested; UL, CSA, and CE compliant.
- InPower™ PC-based service tool available for detailed diagnostics.

Operator/display panel

- Manual off switch
- Alpha-numeric display with pushbutton access for viewing engine and alternator data and providing setup, controls and adjustments (English or international symbols)
- LED lamps indicating generator set running, not in auto, common warning, common shutdown, manual run mode and remote start
- Suitable for operation in ambient temperatures from -40 °C to +70 °C
- Bargraph display (optional)

AC protection

- Over current warning and shutdown
- Over and under voltage shutdown
- Over and under frequency shutdown
- Over excitation (loss of sensing) fault
- Field overload

Engine protection

- Overspeed shutdown
- Low oil pressure warning and shutdown
- High coolant temperature warning and shutdown

- Low coolant level warning or shutdown
- Low coolant temperature warning
- High, low and weak battery voltage warning
- Fail to start (overcrank) shutdown
- Fail to crank shutdown
- Redundant start disconnect
- Cranking lockout
- Sensor failure indication
- Low fuel level warning or shutdown

Alternator data

- Line-to-Line and Line-to-neutral AC volts
- 3-phase AC current
- Frequency
- Total kVa

Engine data

- DC voltage
- Lube oil pressure
- Coolant temperature
- Engine speed

Other data

- Generator set model data
- Start attempts, starts, running hours
- Fault history
- RS485 Modbus® interface
- Data logging and fault simulation (requires InPower service tool)

Digital governing (optional)

- Integrated digital electronic isochronous governor
- Temperature dynamic governing

Digital voltage regulation

- Integrated digital electronic voltage regulator
- 2-phase Line-to-Line sensing
- Configurable torque matching

Control functions

- Time delay start and cooldown
- Cycle cranking
- PCCNet interface
- (2) Configurable inputs
- (2) Configurable outputs
- Remote emergency stop
- Automatic Transfer Switch (ATS) control
- Generator set exercise, field adjustable

Options

- Auxiliary output relays (2)
- Remote annunciator with (3) configurable inputs and (4) configurable outputs
- **PMG alternator excitation**
- PowerCommand 500/550 for remote monitoring and alarm notification (accessory)
- Auxiliary, configurable signal inputs (8) and configurable relay outputs (8)

- AC output analog meters (bargraph)
 - Color-coded graphical display of:
 - 3-phase AC voltage
 - 3-phase current
 - Frequency
 - kVa
- Remote operator panel
- PowerCommand 2.3 control with AmpSentry protection

Ratings definitions

Emergency Standby Power (ESP):

Applicable for supplying power to varying electrical load for the duration of power interruption of a reliable utility source. Emergency Standby Power (ESP) is in accordance with ISO 8528. Fuel Stop power in accordance with ISO 3046, AS 2789, DIN 6271 and BS 5514.

Limited-Time Running Power (LTP):

Applicable for supplying power to a constant electrical load for limited hours. Limited Time Running Power (LTP) is in accordance with ISO 8528.

Prime Power (PRP):

Applicable for supplying power to varying electrical load for unlimited hours. Prime Power (PRP) is in accordance with ISO 8528. Ten percent overload capability is available in accordance with ISO 3046, AS 2789, DIN 6271 and BS 5514.

Base Load (Continuous) Power (COP):

Applicable for supplying power continuously to a constant electrical load for unlimited hours. Continuous Power (COP) in accordance with ISO 8528, ISO 3046, AS 2789, DIN 6271 and BS 5514.

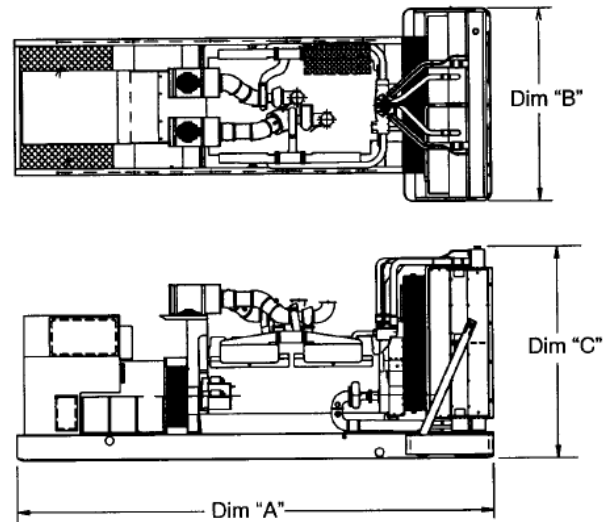

This outline drawing is for reference only. See respective model data sheet for specific model outline drawing number.

Do not use for installation design





Model	Dim "A" mm (in.)	Dim "B" mm (in.)	Dim "C" mm (in.)	Set weight* kg (lbs.)
Open set				
C125D6D	2867 (113)	1016 (40)	1415 (56)	1470 (3240)
C150D6D	2867 (113)	1016 (40)	1415 (56)	1470 (3240)
C175D6D	2867 (113)	1016 (40)	1415 (56)	1470 (3240)
C200D6D	2867 (113)	1016 (40)	1415 (56)	1470 (3240)
Weather protective enclosure				
C125D6D	2867 (113)	1016 (40)	1836 (72)	1600 (3527)
C150D6D	2867 (113)	1016 (40)	1836 (72)	1600 (3527)
C175D6D	2867 (113)	1016 (40)	1836 (72)	1600 (3527)
C200D6D	2867 (113)	1016 (40)	1836 (72)	1600 (3527)
Sound attenuated enclosure Level 2				
C125D6D	3621 (143)	1016 (40)	1836 (72)	1649 (3635)
C150D6D	3621 (143)	1016 (40)	1836 (72)	1649 (3635)
C175D6D	3621 (143)	1016 (40)	1836 (72)	1649 (3635)
C200D6D	3621 (143)	1016 (40)	1836 (72)	1649 (3635)
Sound attenuated enclosure Level 2				
C125D6D	4061 (160)	1016 (40)	1836 (72)	1665 (3671)
C150D6D	4061 (160)	1016 (40)	1836 (72)	1665 (3671)
C175D6D	4061 (160)	1016 (40)	1836 (72)	1665 (3671)
C200D6D	4061 (160)	1016 (40)	1836 (72)	1665 (3671)

Refer to drawings for specific weights and dimensions

* Weights above are average. Actual weight varies with product configuration.

Codes and standards

Codes or standards compliance may not be available with all model configurations – consult factory for availability.

	<p>This generator set is designed in facilities certified to ISO 9001 and manufactured in facilities certified to ISO 9001 or ISO 9002.</p>		<p>The generator set is available Listed to UL 2200, Stationary Engine Generator Assemblies.</p>
	<p>The Prototype Test Support (PTS) program verifies the performance integrity of the generator set design. Cummins products bearing the PTS symbol meet the prototype test requirements of NFPA 110 for Level 1 systems.</p>	<p>U.S. EPA</p>	<p>Engine certified to U.S. EPA SI Stationary Emission Regulation 40 CFR, Part 60.</p>
	<p>All low voltage models are CSA certified to product class 4215-01.</p>	<p>International Building Code</p>	<p>The generator set is certified to International Building Code (IBC) 2012.</p>

Warning: Back feed to a utility system can cause electrocution and/or property damage. Do not connect to any building's electrical system except through an approved device or after building main switch is open.

For more information contact your local Cummins distributor or visit power.cummins.com

Our energy working for you.™





Generator Set Data Sheet

Model: **C200D6D**
 Frequency: 60 Hz
 Fuel Type: **Diesel**
 KW Rating: **200 Standby**
 180 Prime
 Emissions level: EPA Tier 3, Stationary Emergency

Exhaust Emission Data Sheet:	EDS-3046
Exhaust Emission Compliance Sheet:	EPA-2035
Sound Performance Data Sheet:	MSP-4010
Cooling Performance Data Sheet:	MCP-2050
Prototype Test Summary Data Sheet:	PTS-636

Fuel Consumption	Standby				Prime			
	kW (kVA)				kW (kVA)			
Ratings	200 (250)				180 (225)			
Load	1/4	1/2	3/4	Full	1/4	1/2	3/4	Full
US gph	5.7	8.7	11.7	14.9	5.3	8	10.7	13.6
L/hr	21.57	32.92	44.28	56.39	20.06	30.28	40.49	51.47

Engine	Standby rating	Prime rating
Engine Manufacturer	Cummins Inc.	
Engine Model	QSB7-G5	
Configuration	Cast iron, in-line, 6 cylinders	
Aspiration	Turbocharged and charge air cooled	
Gross Engine Power Output, kWm (bhp)	242 (324)	208 (279)
BMEP at set rated load, kPa (psi)	2276 (330)	2063 (299)
Bore, mm (in)	107 (4.21)	
Stroke, mm (in)	124 (4.88)	
Rated Speed, rpm	1800	
Piston Speed, m/s (ft/min)	7.44 (1464)	
Compression Ratio	17.2:1	
Lube Oil Capacity, L (qt)	17.4 (18.38)	
Overspeed limit, rpm	2250	

Fuel Flow

Maximum Fuel Flow, L/hr (US gph)	103 (27.0)
Maximum Fuel Inlet Restriction with Clean Filter, mm Hg (in Hg)	127 (5.0)

Air	Standby rating	Prime rating
Combustion Air, m ³ /min (scfm)	15.86 (560)	15.38 (543)
Maximum Air Cleaner Restriction with Clean Filter, kPa (in H ₂ O)	3.7 (15)	

Exhaust

Exhaust Flow at set rated load, m ³ /min (cfm)	40.74 (1439)	37.8 (1335)
Exhaust Temperature, °C (°F)	512.22 (954)	484.44 (904)
Maximum Back Pressure, kPa (in H ₂ O)	10 (40.19)	10 (40.19)
Actual Exhaust Back Pressure with CPG Sound level 2 Enclosure Muffler, kPa (in H ₂ O)	10 (40.19)	9.9 (39.78)
Actual Exhaust Back Pressure with CPG Weather Enclosure Muffler, kPa (in H ₂ O)	8.4 (33.76)	7.8 (31.47)

Standard Set-Mounted Radiator Cooling

Ambient Design, °C (°F)	49 (120.2)	
Fan Load, kW _m (HP)	14.02 (18.8)	
Coolant Capacity (with radiator), L (US Gal)	22 (5.9)	
Cooling System Air Flow, m ³ /min (scfm)	305.82 (10800)	
Total Heat Rejection, MJ/min (Btu/min)	10.06 (9538)	9.44 (8952)
Maximum Cooling Air Flow Static Restriction, kPa (in H ₂ O)	0.12 (0.5)	

Weight²

Unit Wet Weight kgs (lbs)

Refer to drawings for specific weights and dimensions

Notes:

¹ For non-standard remote installations contact your local Cummins Power Generation representative.

² Weights represent a set with standard features. See outline drawing for weights of other configurations.

Derating Factors

Standby	Engine power available up to 2148 m (7049 ft.) at ambient temperatures up to 40° C (104° F) and 1086 m (3563 ft.) at 50° C (122° F). Consult your Cummins distributor for temperature and ambient requirements outside these parameters.
Prime	Engine power available up to 1944 m (6377 ft.) at ambient temperatures up to 40° C (104° F) and 811 m (2660 ft.) at 50° C (122° F). Consult your Cummins distributor for temperature and ambient requirements outside these parameters.

Ratings Definitions

Emergency Standby Power (ESP):	Limited-time Running Power (LTP):	Prime Power (PRP):	Base Load (continuous) Power (COP):
Applicable for supplying power to varying electrical load for the duration of power interruption of a reliable utility source. Emergency Standby Power (ESP) is in accordance with ISO 8528. Fuel Stop power in accordance with ISO 3046, AS 2789, DIN 6271 and BS 5514.	Applicable for supplying power to a constant electrical load for limited hours. Limited Time Running Power (LTP) is in accordance with ISO 8528.	Applicable for supplying power to varying electrical load for unlimited hours. Prime Power (PRP) is in accordance with ISO 8528. Ten percent overload capability is available in accordance with ISO 3046, AS 2789, DIN 6271 and BS 5514.	Applicable for supplying power continuously to a constant electrical load for unlimited hours. Continuous Power (COP) is in accordance with ISO 8528, ISO 3046, AS 2789, DIN 6271 and BS 5514.

North America
1400 73rd Avenue N.E.
Minneapolis, MN 55432
USA

Phone 763 574 5000
 Fax 763 574 5298

Our energy working for you.™

©2021 Cummins Inc. All rights reserved.
 Cummins is a registered trademarks of Cummins Inc. PowerCommand, AmpSentry, InPower and "Our energy working for you." are trademarks of Cummins. Other company, product, or service names may be trademarks or service marks of others. Specifications are subject to change without notice.
 NAD-6374-EN (03/25) A061F589



power.cummins.com

Alternator Data

Standard Alternators	Single phase ²	Three Phase ¹			
		120 °C			
Maximum Temperature Rise above 40 °C Ambient	120 °C	120 °C			
Feature Code	BB90-2	B946-2	B986-2	B952-2	B943-2
Alternator Data Sheet Number	ADS-213	ADS-213	ADS-212	ADS-212	ADS-212
Voltage Ranges	120/240	120/208	120/240	347/600	277/480
Voltage Feature Code	R104-2	R098-2	R106-2	R114-2	R002-2
Surge kW	205.7	211.1	213.4	214.3	213.4
Motor Starting kVA (at 90% sustained voltage) Shunt	770	770	672	770	770
Motor Starting kVA (at 90% sustained voltage) PMG	920	920	791	920	920
Full load Current Amps at Standby Rating	833	694	602	240	301

Alternator Data

Standard Alternators	Three phase ¹			
	105 °C	105 °C	105 °C	105 °C
Maximum Temperature Rise above 40 °C Ambient	105 °C	105 °C	105 °C	105 °C
Feature Code	BB94-2	BB95-2	BB92-2	BB93-2
Alternator Data Sheet Number	ADS-212	ADS-212	ADS-212	ADS-213
Voltage Ranges	120/240	277/480	347/600	120/208
Voltage Feature Code	R106-2	R002-2	R114-2	R098-2
Surge kW	213.4	213.4	214.3	211.1
Motor Starting kVA (at 90% sustained voltage) Shunt	770	770	770	770
Motor Starting kVA (at 90% sustained voltage) PMG	920	920	920	920
Full load current amps at standby rating	602	301	240	694

Notes:

¹ Single phase power can be taken from a three phase generator set at up to 2/3 set rated 3-phase kW at 1.0 power factor

² Full single phase output up to full set rated 3-phase kW at 1.0 power factor

Formulas for Calculating Full Load Currents:

$$\frac{\text{Three phase output}}{\text{Voltage} \times 1.73 \times 0.8} = \frac{\text{kW} \times 1000}{\text{Voltage} \times 1.73 \times 0.8}$$

$$\frac{\text{Single phase output}}{\text{Voltage}} = \frac{\text{kW} \times \text{SinglePhaseFactor} \times 1000}{\text{Voltage}}$$

Warning: Back feed to a utility system can cause electrocution and/or property damage. Do not connect to any building's electrical system except through an approved device or after building main switch is open.

North America
1400 73rd Avenue N.E.
Minneapolis, MN 55432
USA

Phone 763 574 5000
 Fax 763 574 5298

Our energy working for you.™

©2021 Cummins Inc. All rights reserved.
 Cummins is a registered trademarks of Cummins Inc. PowerCommand, AmpSentry, InPower and "Our energy working for you." are trademarks of Cummins. Other company, product, or service names may be trademarks or service marks of others. Specifications are subject to change without notice.
 NAD-6374-EN (03/25) A061F589



power.cummins.com



PowerCommand[®]

1.1 Control System



Description

The PowerCommand control system is a microprocessor-based generator set monitoring, metering and control system designed to meet the demands of today's engine driven generator sets. The integration of all control functions into a single control system provides enhanced reliability and performance compared to conventional generator set control systems. These control systems have been designed and tested to meet the harsh environment in which gensets are typically applied.

Features

Easy to view: HMI 211RS for residential use. 128 x 64 pixel graphic LED backlight LCD.

Easy to use: Tactile buttons for generator set start/stop. Residential Standby display for convenient use.

Modbus[®] interface: Eliminates need for MODLON.

Progressive protective functions: Advanced Overcurrent Protection – Generator set monitoring & protection.

Digital voltage regulation: Single phase full wave SCR type regulator compatible with either shunt or PMSG systems.

Digital engine speed governing: Provides isochronous frequency regulation.

12 and 24 VDC battery operation.

Automatic mains failure: Smooth & automatic transfer and re-transfer of load from utility to generator set & vice-versa.

Exerciser clock: Runs generator set exerciser routines for dependability of operation.

Warranty and service: Backed by a comprehensive warranty and worldwide distributor service network.

Certification: Suitable for use on generator sets that are designed, manufactured, tested and certified to relevant UL, NFPA, ISO, IEC Mil Std., CE, UKCA and CSA standards.

PowerCommand Digital Generator Set Control PCC 1302



Description

The PowerCommand generator set control is suitable for use on a wide range of generator sets in non-parallel applications. The PowerCommand control is compatible with shunt or PMG excitation style. It is suitable for use with reconnectable or non-reconnectable generators, and it can be configured for any frequency, voltage and power connection from 120-600 VAC Line-to-Line.

Power for this control system is derived from the generator set starting batteries. The control functions over a voltage range from 8 VDC to 30 VDC.

Features

- 12 and 24 VDC battery operation.
- Digital voltage regulation.
- Digital engine speed governing (where applicable) - Provides isochronous frequency regulation.
- Full authority engine communications (where applicable) - Provides communication and control with the Engine Control Module (ECM).
- Common harnessing - with higher feature Cummins controls allows for easy field upgrades.
- Generator set monitoring - Monitors status of all critical engine and alternator functions.
- Digital genset metering (AC and DC).
- Genset battery monitoring system - to sense and warn against a weak battery condition.
- Engine starting - Includes relay drivers for starter, fuel shut off (FSO), glow plug/spark ignition power and switch B+ applications.
- Generator set protection - Protects engine and alternator.
- Advanced serviceability - using InPower™, a PC-based software service tool.
- Environmental protection - The control system is designed for reliable operation in harsh environments. The main control board is a fully encapsulated module that is protected from the elements.
- Exerciser function – Routine exercising of generator set.
- Supports dual fuel control.
- Automatic Mains Failure function built in generator set controller. Modbus interface - for interconnecting to customer equipment.

- Configurable inputs and outputs - Four discrete inputs and two dry contact relay outputs.
- Warranty and service - Backed by a comprehensive warranty and worldwide distributor service network.
- Certifications - Suitable for use on generator sets that are designed, manufactured, tested and certified to relevant UL, NFPA, ISO, IEC, Mil Std., CE, UKCA and CSA standards.

Base Control Functions

HMI capability

Operator adjustments - The HMI includes provisions for many set up and adjustment functions.

Generator set hardware data - Access to the control and software part number, generator set rating in kVA and generator set model number is provided from the HMI or InPower™.

Data logs - Includes engine run time, controller on time, number of start attempts.

Fault history - Provides a record of the most recent fault conditions with control hours time stamp. Up to 10 events are stored in the control non-volatile memory.

Alternator data

- Voltage (single or three phase Line-to-Line and Line-to-Neutral)
- Current (single or three phase)
- kVA (three phase and total)
- Frequency
- Engine data
- Starting battery voltage
- Engine speed
- Engine temperature
- Engine oil pressure
- Partial Full Authority Engine (FAE) data (where applicable)
- Service adjustments - The HMI includes provisions for adjustment and calibration of generator set control functions. Adjustments are protected by a password. Functions include:
 - Engine speed governor adjustments
 - Voltage regulation adjustments
 - Cycle cranking
 - Configurable fault set up
 - Configurable output set up
 - Meter calibration
 - Units of measurement

Engine control

SAE-J1939 CAN interface to full authority ECMs (where applicable) - Provides data swapping between genset and engine controller for control, metering and diagnostics.

12 VDC/24 VDC battery operations - PowerCommand will operate either on 12 VDC or 24 VDC batteries.

Isochronous governing (where applicable) - Capable of controlling engine speed within +/-0.25% for any steady state load from no load to full load. Frequency drift will not exceed +/-0.5% for a 33 °C (60 °F) change in ambient temperature over an 8 hour period.

Temperature dependent governing dynamics (with electronic governing) - Modifies the engine governing control parameters as a function of engine temperature. This allows the engine to be more responsive when warm and more stable when operating at lower temperature levels.

Remote start mode - Accepts a ground signal from remote devices to automatically start the generator set and immediately accelerate to rated speed and voltage. The remote start signal will also wake up the control from sleep mode. The control can incorporate a time delay start and stop.

Remote and local Emergency stop - The control accepts a ground signal from a local (genset mounted) or remote (facility mounted) Emergency stop switch to cause the generator set to immediately shut down. The generator set is prevented from running or cranking with the switch engaged. If in sleep mode, activation of either Emergency stop switch will wake up the control.

Sleep mode - The control includes a configurable low current draw state to minimize starting battery current draw when the genset is not operating. The control can also be configured to go into a low current state while in auto for Prime applications or applications without a battery charger.

Engine starting - The control system supports automatic engine starting. Primary and backup start disconnects are achieved by one of three methods: magnetic pickup, battery charging alternator feedback or main alternator output frequency. The control also supports configurable glow plug control when applicable.

Cycle cranking - Configurable for the number of starting cycles (1 to 7) and duration of crank and rest periods. Control includes starter protection algorithms to prevent the operator from specifying a starting sequence that might be damaging.

Time delay start and stop (cooldown) - Configurable for time delay of 0-300 seconds prior to starting after receiving a remote start signal and for time delay of 0-600 seconds prior to shut down after signal to stop in normal operation modes. Default for both time delay periods is 0 seconds.

Alternator control

The control includes an integrated line-to-line sensing voltage regulation system that is compatible with shunt or PMG excitation systems. The voltage regulation system is full wave rectified and has an SCR output for good motor starting capability. Major system features include:

Digital output voltage regulation - Capable of regulating output voltage to within +/-1.0% for any loads between no load and full load. Voltage drift will not exceed +/-1.5% for a 40 °C (104 °F) change in temperature in an eight hour period. On engine starting or sudden load acceptance, voltage is controlled to a maximum of 5% overshoot over nominal level.

The automatic voltage regulator feature can be disabled to allow the use of an external voltage regulator.

Torque-matched V/Hz overload control - The voltage roll-off set point and rate of decay (i.e. the slope of the V/Hz curve) is adjustable in the control.

Protective Functions

On operation of a protective function the control will indicate a fault by illuminating the appropriate status LED on the HMI, as well as display the fault code and fault description on the LCD. The nature of the fault and time of occurrence are logged in the control. The service manual and InPower service tool provide service keys and procedures based on the service codes provided. Protective functions include:

Battle short mode

When enabled and the battle short switch is active, the control will allow some shutdown faults to be bypassed. If a bypassed shutdown fault occurs, the fault code and description will still be annunciated, but the genset will not shutdown. This will be followed by a fail to shutdown fault. Emergency stop shutdowns and others that are critical for proper operation are not bypassed. Please refer to the Control Application Guide or Manual for list of these faults.

Configurable alarm and status inputs

The control accepts up to four alarm or status inputs (configurable contact closed to ground or open) to indicate a configurable (customer-specified) condition. The control is programmable for warning, shutdown or status indication and for labelling the input.

Emergency stop

Annunciated whenever either Emergency stop signal is received from external switch.

General engine protection

Low and high battery voltage warning - Indicates status of battery charging system (failure) by continuously monitoring battery voltage.

Weak battery warning - The control system will test the battery each time the generator set is signaled to start and indicate a warning if the battery indicates impending failure.

Fail to start (overcrank) shutdown - The control system will indicate a fault if the generator set fails to start by the completion of the engine crank sequence.

Fail to crank shutdown - Control has signaled starter to crank engine but engine does not rotate.

Cranking lockout - The control will not allow the starter to attempt to engage or to crank the engine when the engine is rotating.

Hydro mechanical fuel system engine protection

Overspeed shutdown - Default setting is 115% of nominal.

Low lube oil pressure warning/shutdown - Level is pre-set (configurable with InPower) to match the capabilities of the engine used. Control includes time delays to prevent nuisance alarms.

High lube oil temperature warning/shutdown - Level is pre-set (configurable with InPower) to match the capabilities of the engine used. Control includes time delays to prevent nuisance alarms.

High engine temperature warning/shutdown - Level is pre-set (configurable with InPower) to match the capabilities of the engine used. Control includes time delays to prevent nuisance alarms.

Low coolant temperature warning - Indicates that engine temperature may not be high enough for a 10 second start or proper load acceptance.

Sensor failure indication - Logic is provided on the base control to detect analog sensor or interconnecting wiring failures.

Full authority electronic engine protection

Engine fault detection is handled inside the engine ECM. Fault information is communicated via the SAE-J1939 data link for annunciation in the HMI

Alternator protection

High AC voltage shutdown (59) - Output voltage on any phase exceeds pre-set values. Time to trip is inversely proportional to amount above threshold. Values adjustable from 105-130% of nominal voltage, with time delay adjustable from 0.1-10 seconds. Default value is 110% for 10 seconds.

Low AC voltage shutdown (27) - Voltage on any phase has dropped below a pre-set value. Adjustable over a range of 50-95% of reference voltage, time delay 2-20 seconds. Default value is 85% for 10 seconds.

Overcurrent warning/shutdown - Implementation of the thermal damage curve with instantaneous trip level calculated based on current transformer ratio and application power rating.

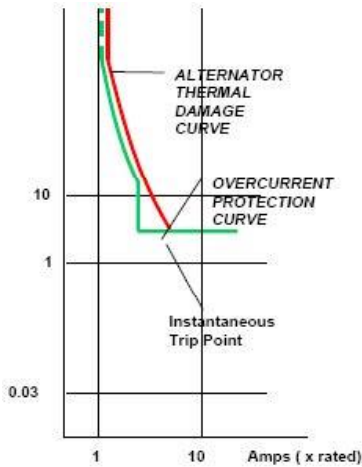

Under frequency shutdown (81 u) - Generator set output frequency cannot be maintained. Settings are adjustable from 2-10 Hz below nominal governor set point, for a 5-20 second time delay. Default: 6 Hz, 10 seconds.

Over frequency shutdown/warning (81 o) - Generator set is operating at a potentially damaging frequency level. Settings are adjustable from 2-10 Hz above nominal governor set point for a 1-20 second time delay. Default: 6 Hz, 10 seconds, enabled.

Loss of sensing voltage shutdown - Shutdown of generator set will occur on loss of voltage sensing inputs to the control.

Field overload shutdown - Uses field voltage to shutdown generator set when a field overload condition occurs.

Advanced Functions

Automatic mains failure*

The built in AMF feature provides the automatic transfer and re-transfer of the load from utility to generator set and vice-versa.

- Automatically starts-stops the generator set in the event of utility failure.
- Annunciates faults.

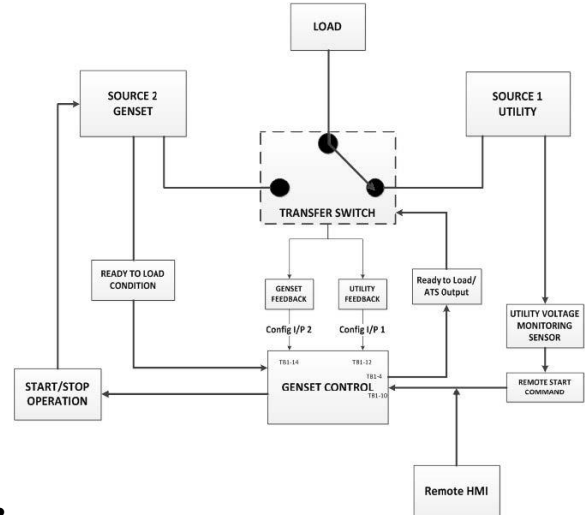

- * A utility voltage monitoring sensor (as shown in the AMF diagram above) must be connected in order to use the AMF feature on the 1302 control. Use Schneider Electric Relay RSB1A120U7 and Socket RSZE1S35M.

Exerciser clock

The exerciser clock runs the generator set exerciser routines for dependability of operation.

Field Control Interface

Input signals to the base control include:

- Remote start
- Local and Emergency stop
- Configurable inputs: Control includes (4) input signals from customer discrete devices that are configurable for warning, shutdown or status indication, as well as message displayed.

Output signals from the PowerCommand control include:

- Configurable relay outputs: Control includes (2) relay output contacts rated at 2 A. These outputs can be configured to activate on any control warning or shutdown fault as well as ready to load, not in auto, common alarm, common warning and common shutdown.
- Ready to load (generator set running) signal: Operates when the generator set has reached 90% of rated speed and voltage and latches until generator set is switched to off or idle mode.

PowerCommand Human Machine Interface HMI211



Description

This control system includes an intuitive operator interface panel that allows for complete genset control as well as system metering, fault annunciation, configuration and diagnostics. The interface includes five generator set status LED lamps with both internationally accepted symbols and English text to comply with customer needs. The interface also includes an LED backlit LCD display with tactile feel soft-switches for easy operation and screen navigation. It is configurable for units of measurement and has adjustable screen contrast and brightness.

The *run/off/auto* switch function is integrated into the interface panel.

All data on the control can be viewed by scrolling through screens with the navigation keys. The control displays the current active fault and a time-ordered history of the five previous faults.

Features

- LED indicating lamps:
 - Remote start
 - Not in auto
 - Shutdown
 - Warning
 - Auto
 - Run
- 128 x 64 pixels graphic LED backlight LCD.
- Four tactile feel membrane switches for LCD defined operation. The functions of these switches are defined dynamically on the LCD.
- Two tactile feel membrane switches dedicated for off and back.
- Allows for complete genset control setup.
- Certifications: Suitable for use on generator sets that are designed, manufactured, tested and certified to relevant UL, NFPA, ISO, IEC, Mil Std., CE, UKCA and CSA standards.
- HMI 211RS provides convenience for residential use.

Communications Connections

PC tool interface - This RS-485 communication port allows the HMI to communicate with a personal computer running InPower.

This RS-485 communication port allows the HMI to communicate with the main control board.

Mechanical Drawing

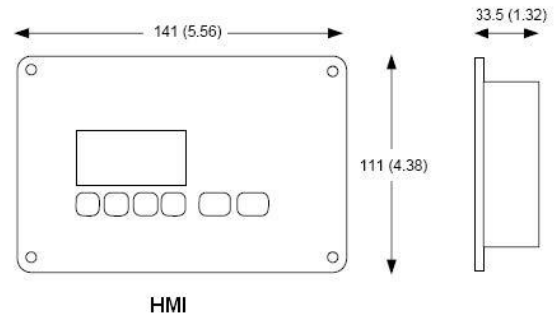

Dimensions: mm (inches)

Software

InPower (beyond 6.0 version) is a PC-based software service tool that is designed to directly communicate to PowerCommand generator sets and transfer switches, to facilitate service and monitoring of these products.

Environment

The control is designed for proper operation without recalibration in ambient temperatures from -40 °C (-40 °F) to +70 °C (158 °F), and for storage from -55 °C (-67 °F) to +80 °C (176 °F). Control will operate with humidity up to 95%, non-condensing.

The HMI is designed for proper operation in ambient temperatures from -40 °C* (-40 °F) to +70 °C (158 °F), and for storage from -40 °C* (-40 °F) to +80 °C (176 °F).

The control board is fully encapsulated to provide superior resistance to dust and moisture. Display panel has a single membrane surface, which is impervious to effects of dust, moisture, oil and exhaust fumes. This panel uses a sealed membrane to provide long reliable service life in harsh environments.

The control system is specifically designed and tested for resistance to RFI/EMI and to resist effects of vibration to provide a long reliable life when mounted on a generator set. The control includes transient voltage surge suppression to provide compliance to referenced standards.

* Heater accessory (pn: A040H853) is available for enhanced operation below -20 °C

Certifications

PowerCommand meets or exceeds the requirements of the following codes and standards:

- NFPA 110 for level 1 and 2 systems.
- ISO 8528-4: 1993 compliance, controls and switchgear.
- CE and UKCA marking: The control system is suitable for use on generator sets to be CE and UKCA-marked.
- EN 50081-1,2 residential/light industrial emissions or industrial emissions.
- EN 50082-1,2 residential/light industrial or industrial susceptibility.
- ISO 7637-2, level 2: DC supply surge voltage test.
- Mil Std. 202C, Method 101 and ASTM B117: Salt fog test.
- PowerCommand control systems and generator sets are designed and manufactured in ISO 9001 certified facilities.
- UL 6200 recognized and suitable for use on UL 2200 Listed generator sets.
- CSA C282-M1999 compliance.
- CSA 22.2 No. 14 M91 industrial controls.

Warranty

All components and subsystems are covered by an express limited one year warranty. Other optional and extended factory warranties and local distributor maintenance agreements are available

Accessories

1301-1302 Upgrade Kit (HM)	0541-1431
PowerCommand 500 (LAN)	A040X126
Remote HMI 211	0541-1394
Remote HMI 211RS	A046K103
I/O Expansion (Aux 101)	0541-1291
HMI Heater Accessory Kit	A040H853

Parts Ordering Information

1302 Control Board	0327-1617-02
1302 control Board – Arrow	A043W505
Aux 104 (Governor Control)	0327-1507
HMI 211 Without Heater	0300-6014
HMI 211 with Heater	A026G237

Additional Resources

Resource	Where to find
1302 Service Manual	QSOL
Accessories Catalog	cumminspower.com
Additional Controls Information	PowerSuite Library



For more information contact your local Cummins distributor or visit power.cummins.com

Our energy working for you.™





Dual wall sub-base diesel fuel tanks - 10-200 kW generator sets



Description

Cummins® offers two series of fuel tanks (basic series and regional series) for the 10~125 kW diesel generator sets. The “basic” series of fuel tanks provide economical solutions for areas with no or minimal local/regional code requirements on diesel fuel tanks. The footprint of “basic” tanks matches the generator set’s footprint. The “regional” series of fuel tanks provide flexible and upgradable solutions for areas with extensive local/regional code requirements on diesel fuel tanks. The footprint of the “regional” series of fuel tanks extends beyond the generator set to allow room for installation of optional features at factory or accessories in the field for meeting local/regional code requirements or customer specification on diesel fuel tanks. All fuel tanks and optional features are compatible with factory installed enclosures.

These tanks are constructed of heavy gauge steel and include an internally reinforced baffle structure for supporting the generator set. The fuel tank design features fewer seams and welds for better corrosion resistance performance.

These tanks are pre-treated with a conversion coating and then finished with a textured powder paint. The paint has superior UV and chemical resistance with best-in-class adhesion, flexibility, and durability to resist chipping and substrate corrosion. Both interior compartments are treated with a rust preventative for extended corrosion protection.

These tanks are UL and ULC Listed as secondary containment generator base tanks. Inner and outer containments are leak checked per UL and ULC testing procedures to ensure their integrity.

These fuel tanks are offered in various sizes to satisfy different fuel capacities requirements.

Compatible generator set model

Engine	D1703M	V2203M	4BT3.3-G5	4BTAA3.3-G7	QSB5-G5	QSB7-G5
Generator set model names	C10D6	C20D6	C25D6	C50D6	C50D6C	C125D6D
	C15D6		C30D6	C60D6	C60D6C	C150D6D
			C35D6		C80D6C	C175D6D
			C40D6		C100D6C	C200D6D
					C125D6C	

Basic fuel tanks

Standard features:

UL 142 and ULC-S601 listed - Minimum 110% secondary containment capacity.

NFPA and IFC - Capable of meeting NFPA 30 and NFPA 110 codes with available factory installed optional features.

Emergency pressure relief vents - Ensure adequate ventilation of the primary and secondary tank compartments under extreme temperature and emergency conditions.

Normal atmospheric vent - "Mushroom" style vent ensures adequate venting of the primary tank during fill, generator set running and temperature variations. Raised above fuel fill.

Raised fuel fill - includes lockable sealed fuel cap.

Lifting eyes - Allow lifting of fuel tank with generator set installed.

Optional features:

Secondary containment basin switch (rupture switch) - Activates a warning in the event of a primary tank leak. Side mounted.

Low fuel level switch - Activates a warning when 40% of the fuel is left in the tank.

Fuel level gauge - Provides direct reading of fuel level. Top mounted.

Electric fuel level sender with gauge - Allows remote electrical monitoring of fuel tank level. Flying leads for customer connection.

Tank to foundation clearance - 2-inch bolt-thru risers allow visual inspection under tank including rodent barrier.

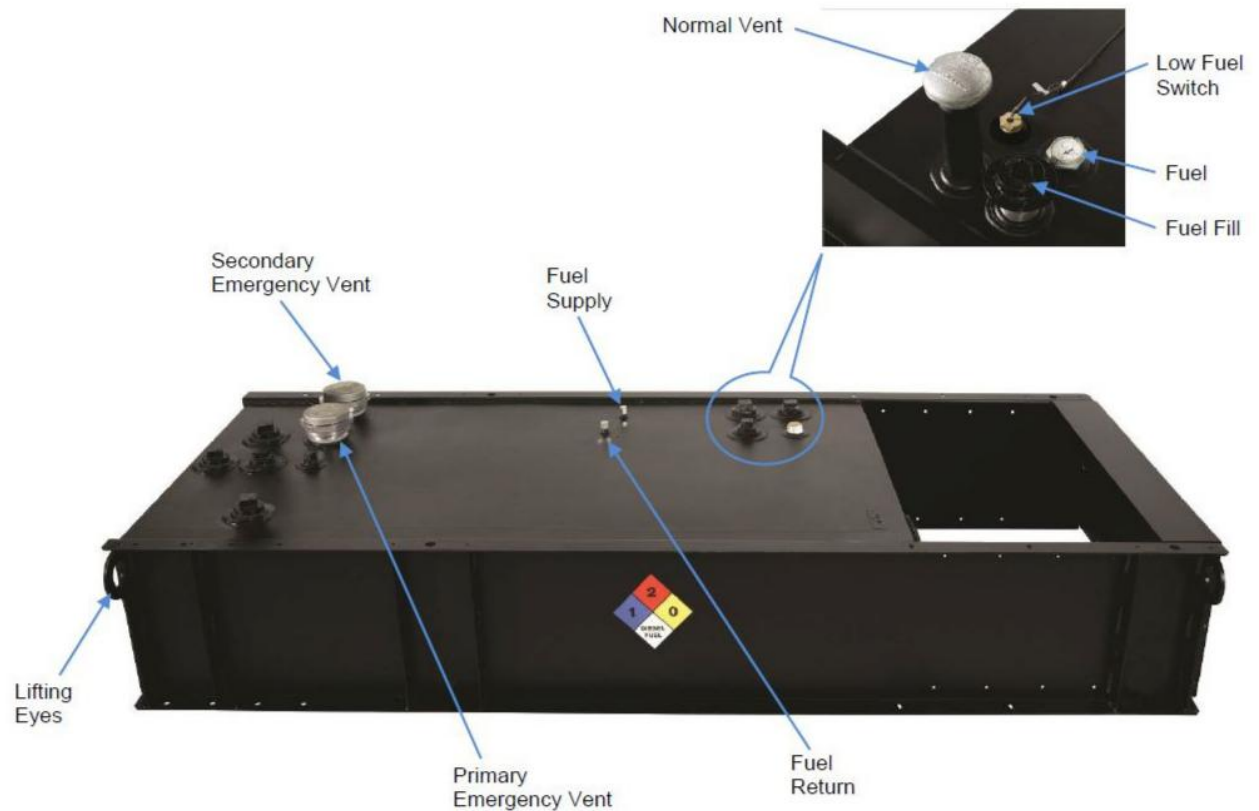

*Picture is for reference only. See outline drawing for tank specific information by model.

Basic tanks

Generator set Standby power output	Generator set model	Engine model	Fuel consumption (100% load, Standby)	Tank feature code	Minimum run time feature	Tank dimensions (L x W x H)	Nominal dry weight*	Tank usable volume	Actual run time
kW			gal/hr		hr	inch	lbs	gal	hr
10	C10D6	D1703M	1.12	C319-2	24	65.7 x 34 x 13	310	46	41
				C320-2	48	65.7 x 34 x 23	583	91	81
15	C15D6	D1703M	1.38	C319-2	24	65.7 x 34 x 13	310	46	33
				C320-2	48	65.7 x 34 x 23	583	91	66
20	C20D6	V2203M	1.81	C319-2	24	65.7 x 34 x 13	310	46	25
				C320-2	48	65.7 x 34 x 23	583	91	50
25	C25D6	4BT3.3-G5	2.42	C319-2	24	87.6 x 34 x 15	456	74	31
				C320-2	48	87.6 x 34 x 23	669	132	54
				C342-2	72	96 x 31 x30	977	230	95
30	C30D6	4BT3.3-G5	2.81	C319-2	24	87.6 x 34 x 15	456	74	26
				C320-2	48	87.6 x 34 x 32	908	195	69
				C342-2	72	96 x 31 x30	977	230	81
35	C35D6	4BT3.3-G5	3.16	C319-2	24	87.6 x 34 x 23	669	132	42
				C320-2	48	87.6 x 34 x 32	908	195	62
				C342-2	72	96 x 31 x30	977	230	72
40	C40D6	4BT3.3-G5	3.66	C319-2	24	87.6 x 34 x 23	669	132	36
				C320-2	48	87.6 x 34 x 32	908	195	53
				C341-2	72	96 x 31 x30	977	230	62
50	C50D6	4BTAA3.3-G7	4.25	C319-2	24	87.6 x 34 x 23	669	132	31
				C320-2	48	87.6 x 34 x 42	977	263	62
				C341-2	72	96 x 31 x30	977	230	54
60	C60D6	4BTAA3.3-G7	5.04	C319-2	24	87.6 x 34 x 23	669	132	26
				C320-2	48	87.6 x 34 x 42	977	263	52
				C340-2	72	96 x 31 x30	977	230	45
50	C50D6C	QSB5-G5	5.30	C319-2	24	117 x 40 x 25	809	260	49
				C320-2	48	117 x 40 x 25	809	260	49
60	C60D6C	QSB5-G5	6.10	C319-2	24	117 x 40 x 25	809	260	42
				C320-2	48	117 x 40 x 33	966	353	57
80	C80D6C	QSB5-G5	7.30	C319-2	24	117 x 40 x 25	809	260	35
				C320-2	48	117 x 40 x 33	966	353	48
100	C100D6C	QSB5-G5	8.90	C319-2	24	117 x 40 x 25	809	260	29
				C320-2	48	117 x 40 x 48	1471	526	59
125	C125D6C	QSB5-G6	10.30	C319-2	24	117 x 40 x 25	809	260	25
				C320-2	48	117 x 40 x 48	1471	526	51
125	C125D6D	QSB7-G5	10.1	C319-2	24	117x40x25	809	258	25
				C320-2	48	117x40x48	1471	520	51
150	C150D6D		11.7	C319-2	24	117x40x33	966	350	29
				C320-2	48	180x40x42	2302	737	62
175	C175D6D		13.3	C319-2	24	117x40x33	966	350	26
				C320-2	48	180x40x42	2302	737	55
200	C200D6D		14.9	C319-2	24	117x40x48	1471	520	34
				C320-2	48	180x40x42	2302	737	49

Note: No OFPV is offered on basic fuel tanks.

* All weights are approximate.

Regional tanks

Generator set Standby power output	Generator set model	Engine model	Fuel consumption (100% load, Standby)	Tank feature code	Minimum run time feature	Tank dimensions (L x W x H)	Nominal dry weight*	Tank usable volume	Actual run time w/o OFPV	Actual run time w/OFPV
kW			gal/hr		hr	inch	lbs	gal	hr	hr
125	C125D6D	QSB7-G5	10.1	C301-2	24	180x40x21	1477	351	34	30
				C303-2	48	180x40x42	2302	737	72	69
				C305-2	72	180x40x42	2302	737	72	69
				C307-2	96	180x65.5x35.3	3552	1055	104	98
150	C150D6D		11.7	C301-2	24	180x40x21	1477	351	30	26
				C303-2	48	180x40x42	2302	737	63	59
				C305-2	72	180x65.5x35.3	3552	1055	90	84
175	C175D6D		13.3	C301-2	24	180x40x21	1477	351	26	23
				C303-2	48	180x40x42	2302	737	55	52
				C305-2	72	180x65.5x35.3	3552	1055	79	74
200	C200D6D		14.9	C301-2	24	180x40x21	1477	351	24	21
				C303-2	48	180x40x42	2302	737	49	47
		C305-2		72	180x65.5x35.3	3552	1055	72	66	

Certifications/standards/codes



UL 142 Listed - Cummins dual wall sub-base tanks are UL Listed and constructed in accordance with Underwriters Laboratories Standard UL 142 "steel aboveground tanks for flammable and combustible liquids," as a "secondary containment generator base tank"



NFPA - Cummins tanks are built in accordance with all applicable NFPA codes:

- NFPA 30 - Flammable and Combustible Liquids code
- NFPA 37 - Standard for Installation and use of Stationary Combustible Engine and Gas Turbines
- NFPA 110 - Standard for Emergency and Standby Power Systems



ISO9001 - This product was designed and manufactured in facilities certified to ISO9001.



ULC - Cummins tanks are built in accordance with all applicable ULC codes

For more information contact your local Cummins distributor or visit power.cummins.com

Our energy working for you.™



2025 EPA Tier 3 Exhaust Emission Compliance Statement

C200D6D

Stationary Emergency 60 Hz Diesel Generator Set

Compliance Information:

The engine used in this generator set complies with Tier 3 emissions limit of U.S. EPA New Source Performance Standards for stationary emergency engines under the provisions of 40 CFR 60 Subpart IIII.

Engine Manufacturer: Cummins Inc.
 EPA Certificate Number: SCEXL0409AAD-033
 Effective Date: 12/30/2024
 Date Issued: 12/30/2024
 EPA Engine Family (Cummins Emissions Family): SCEXL0409AAD

Engine Information:

Model: QSB7-G5 NR3 Bore: 4.21 in. (106.9 mm)
 Engine Nameplate HP: 324 Stroke: 4.88 in. (124 mm)
 Type: 4 Cycle, In-line, 6 Cylinder Diesel Displacement: 408 cu. in. (7 liters)
 Aspiration: Turbocharged and Charge Air Cooled Compression ratio: 17.2:1
 Emission Control Device: Exhaust stack diameter: 4 in. (101.6)

Diesel Fuel Emission Limits

D2 Cycle Exhaust Emissions

	Grams per BHP-hr			Grams per kWm-hr		
	<u>NO_x + NMHC</u>	<u>CO</u>	<u>PM</u>	<u>NO_x + NMHC</u>	<u>CO</u>	<u>PM</u>
EPA Emissions Limit	3.0	2.6	0.15	4.0	3.5	0.20

Test methods: EPA emissions recorded per 40 CFR Part 60, 89, 1039, 1065 and weighted at load points prescribed in the regulations for constant speed engines.

Diesel fuel specifications: Cetane number: 40-50, Reference: ASTM D975 No. 2-D, 300-500 ppm Sulphur

Reference conditions: Air Inlet Temperature: 25 °C (77 °F), Fuel Inlet Temperature: 40 °C (104 °F). Barometric Pressure: 100 kPa (29.53 in Hg), Humidity: 10.7 g/kg (75 grains H2O/lb) of dry air; required for NOx correction, Restrictions: Intake Restriction set to a maximum allowable limit for clean filter; Exhaust Back Pressure set to a maximum allowable limit..

Tests conducted using alternate test methods, instrumentation, fuel or reference conditions can yield different results. Engine operation with excessive air intake or exhaust restriction beyond published maximum limits, or with improper maintenance, may result in elevated emission levels.



Exhaust Emission Data Sheet

C200D6D

60 Hz Diesel Generator Set

Engine Information:

Model:	Cummins QSB7-G5 NR3	Bore:	4.21 in. (106.9 mm)
Type:	4 cycle, in-line, 6 cylinder diesel	Stroke:	4.88 in. (123.9 mm)
Aspiration:	Turbocharged and Charge Air Cooled	Displacement:	408 cu. in. (6.7 liters)
Compression Ratio:	17.2:1	Exhaust Stack Diameter:	4 in (101.6 mm)
Emission Control Device:	Turbocharged and Charge Air Cooled		

<u>Performance Data</u>	<u>1/4 Standby</u>	<u>1/2 Standby</u>	<u>3/4 Standby</u>	<u>Full Standby</u>	<u>Full Prime</u>
BHP @ 1800 RPM (60 Hz)	106.9	173.9	241	306.2	277.6
Fuel Consumption (gal/Hr)	5.7	8.7	11.7	14.7	13.4
Exhaust Gas Flow (CFM)	784.8	1125.5	1272.1	1439.3	1335.8
Exhaust Gas Temperature (°F)	723.1	816.5	876.7	954.4	904.2
Exhaust Emission Data					
HC (Total Unburned Hydrocarbons)	0.24	0.10	0.04	0.03	0.03
NOx (Oxides of Nitrogen as NO ₂)	1.87	2.08	2.94	4.65	4.06
CO (Carbon Monoxide)	1.54	0.75	0.33	0.19	0.22
PM (Particulate Matter)	0.15	0.09	0.05	0.02	0.03
Smoke (Bosch)	0.71	0.62	0.44	0.25	0.23
Sulfur Dioxide (SO ₂)	0.17	0.16	0.15	0.14	0.14
All values (except smoke) are cited: g/BHP-hr					

Test Conditions

Data is representative of steady-state engine speed (± 25 RPM) at designated genset loads. Pressures, temperatures, and emission rates were stabilized.

Fuel Specification:	ASTM D975 No. 2-D diesel fuel with 0.03-0.05% sulfur content (by weight), and 40-48 cetane number.
Fuel Temperature:	99 \pm 9 °F (at fuel pump inlet)
Intake Air Temperature:	77 \pm 9 °F
Barometric Pressure:	29.6 \pm 1 in. Hg
Humidity:	NOx measurement corrected to 75 grains H ₂ O/lb dry air
Reference Standard:	ISO 8178

The NOx, HC, CO and PM emission data tabulated here are representative of test data taken from a single engine under the test conditions shown above. Data for the other components are estimated. These data are subjected to instrumentation and engine-to-engine variability. Field emission test data are not guaranteed to these levels. Actual field test results may vary due to test site conditions, installation, fuel specification, test procedures and instrumentation. Engine operation with excessive air intake or exhaust restriction beyond published maximum limits, or with improper maintenance, may result in elevated emission levels.



Sound Data

C200D6D

QSB7-G5 NR3 60Hz Diesel

A-weighted Sound Pressure Level @ 7 meters, dB(A)

See notes 2, 5 and 7-11 listed below

Configuration	Exhaust	Applied Load	Position (Note 2)								8 Position Average
			1	2	3	4	5	6	7	8	
Standard – Unhoused	Infinite Exhaust	100% Standby	86	87	88	89	84	90	90	91	89
F216-2 Weather Aluminum	Mounted	100% Standby	87	86	84	89	85	91	84	88	87
F231-2 Sound Attenuated Level 1, Aluminum	Mounted	100% Standby	84	81	74	75	75	76	76	83	80
F217-2 Sound Attenuated Level 2, Aluminum	Mounted	100% Standby	74	73	72	73	73	73	72	74	73

Average A-weighted Sound Pressure Level @ 1 meter, dB(A)

See notes 1, 5 and 7-14 listed below

Configuration	Exhaust	Applied Load	Octave Band Center Frequency (Hz)											Overall Sound Pressure Level
			16	31.5	63	125	250	500	1000	2000	4000	8000	16000	
Standard – Unhoused	Infinite Exhaust	100% Standby	N/A	47	69	81	91	92	93	91	90	87	91	99
F216-2 Weather Aluminum	Mounted	100% Standby	N/A	44	67	84	92	90	91	89	86	81	83	97
F231-2 Sound Attenuated Level 1, Aluminum	Mounted	100% Standby	N/A	46	62	75	81	81	82	80	77	79	77	89
F217-2 Sound Attenuated Level 2, Aluminum	Mounted	100% Standby	N/A	46	64	73	77	77	78	77	74	73	68	85

A-weighted Sound Pressure Level @ Operator Location, dB(A)

See notes 1, 3, 5 and 7-14 listed below

Configuration	Exhaust	Applied Load	Octave Band Center Frequency (Hz)											Overall Sound Pressure Level
			16	31.5	63	125	250	500	1000	2000	4000	8000	16000	
Standard – Unhoused	Infinite Exhaust	100% Standby	N/A	43	69	79	87	90	90	91	90	89	99	101
F216-2 Weather Aluminum	Mounted	100% Standby	N/A	44	68	80	86	85	83	83	79	76	78	91
F231-2 Sound Attenuated Level 1, Aluminum	Mounted	100% Standby	N/A	50	66	75	81	82	83	79	76	76	66	88
F217-2 Sound Attenuated Level 2, Aluminum	Mounted	100% Standby	N/A	50	68	76	80	80	80	77	75	74	64	87



Sound Data

C200D6D

QSB7-G5 NR3 60Hz Diesel

A-weighted Sound Power Level, dB(A)

See notes 1, 3 and 6-14 listed below

Configuration	Exhaust	Applied Load	Octave Band Center Frequency (Hz)											Overall Sound Power Level
			16	31.5	63	125	250	500	1000	2000	4000	8000	16000	
Standard – Unhoused	Infinite Exhaust	100% Standby	N/A	64	86	99	108	109	110	109	107	104	108	117
F216-2 Weather Aluminum	Mounted	100% Standby	N/A	62	85	102	109	108	109	106	103	99	101	115
F231-2 Sound Attenuated Level 1, Aluminum	Mounted	100% Standby	N/A	64	81	93	99	99	101	99	95	97	95	107
F217-2 Sound Attenuated Level 2, Aluminum	Mounted	100% Standby	N/A	64	82	91	96	95	96	95	93	92	87	103

Exhaust Sound Power Level, dB(A)

See notes 4 and 6-14 listed below

Configuration	Applied Load	Octave Band Center Frequency (Hz)											Overall Sound Power Level
		16	31.5	63	125	250	500	1000	2000	4000	8000	16000	
Open Exhaust (No Muffler)	100% Standby	N/A	63	94	107	117	118	115	114	115	107	95	123

Global Notes:

1. Sound pressure levels at 1 meter are measured per the requirements of ISO 3744, ISO 8528-10, and European Communities Directive 2000/14/EC as applicable. The microphone measurement locations are 1 meter from a reference parallelepiped just enclosing the generator set (enclosed or unenclosed).
2. Seven-meter measurement location 1 is 7 meters (23 feet) from the generator (alternator) end of the generator set, and the locations proceed counterclockwise around the generator set at 45° angles at a height of 1.2 meters (48 inches) above the ground surface.
3. Sound Power Levels are calculated according to ISO 3744, ISO 8528-10, and/or CE (European Union) requirements.
4. Exhaust Sound Levels are measured and calculated per ISO 6798, Annex A.
5. Reference Sound Pressure Level is 20 µPa
6. Reference Sound Power Level is 1 pW (10⁻¹² Watt)
7. Sound data for remote-cooled generator sets are based on rated load without cooling fan noise.
8. Sound data for the generator set with infinite exhaust do not include the exhaust noise contribution
9. Published sound levels are measured at CE certified test site and are subject to instrumentation measurement, installation, and manufacturing variability.
10. Unhoused/Open configuration generator sets refers to generator sets with no sound enclosures of any kind.
11. Housed/Enclosed/Closed/Canopy configuration generator sets refer to generator sets that have noise reduction sound enclosure installed over the generator set and usually integrally attached to the skid base/base frame/fuel container base of the generator set.
12. Published sound levels meet the requirements India's Central Pollution Control Board (Ministry of Environment & Forests), vide GSR 371 (E), which states the A-weighted sound level at 1 meter from any diesel generator set up to a power output rating of 1000kVA shall not exceed 75 dB(A).
13. For updated noise pollution information for India see website: <http://www.envfor.nic.in/legis/legis.html>
14. Sound levels must meet India's Ambient Air Noise Quality Standards detailed for Daytime/Nighttime operation in Noise Pollution (Regulation and Control) Rules, 2000



Prototype Test Support (PTS) 60 Hz test summary



Generator set models	Representative prototype
C125D6D	Model: C200D6D
C150D6D	Engine: QSB7-G5 NR3
C175D6D	Alternator: UCDI274K

The following summarizes prototype testing conducted on the designated representative prototype of the specified models. This testing is conducted to verify the complete generator set electrical and mechanical design integrity. Prototype testing is conducted only on generator sets not sold as new equipment.

Maximum surge power: 211.5 kW
The generator set was evaluated to determine the stated maximum surge power.

Alternator temperature rise:
The highest rated temperature rise (20 °C) test result are reported as follows to verify that worst case temperature rises do not exceed allowable NEMA MG1 limits for class H insulation. Tests were conducted per IEEE 115, rise by resistance and embedded detector, with rated voltages. Only the highest temperatures are reported.

Torsional analysis and testing:
The generator set with UCDI274K was tested to verify that the design is not subjected to harmful torsional stresses. A spectrum analysis of the transducer output was conducted over the speed range of 1710 to 1890 RPM.

Cooling system: 49 °C ambient
0.5 in H2O restriction

The cooling system was tested to determine ambient temperature and static restriction capabilities. The test was performed at full rated load elevated ambient temperature under static restriction conditions.

Durability:
The generator set was subjected to a 500 hour endurance test replicating field duty cycles operating at variable load up to the standby rating based upon MIL-STD-705 to verify structural soundness and durability of the design.

Electrical and mechanical strength:
The generator set was tested to several single phase and three phase faults to verify that the generator can safely withstand the forces associated with short circuit conditions. The generator set was capable of producing full rated output at the conclusion of the testing.

Steady state performance:
The generator set was tested to verify steady state operating performance. It was within the specified maximum limits.

Voltage regulation: ± 0.5%
Random voltage variation: ± 0.5%
Frequency regulation: Isochronous
Random frequency variation: ± 0.25%

Transient performance:
The generator set was tested with the listed alternator to verify single step loading capability as required by NFPA 110. Voltage and frequency response on load addition or rejection were evaluated. The following results were recorded at 0.8 power factor:

Full load acceptance:

Voltage dip:	29.4%
Recovery time:	3.3 seconds
Frequency dip:	20.3%
Recovery time:	4.4 seconds

Full load rejection:

Voltage rise:	32.7%
Recovery time:	1.4 seconds
Frequency rise:	11%
Recovery time:	2.1 seconds

All data based on 0.8 power factor:

Harmonic analysis:
(per MIL-STD-705B, Method 601.4)

Harmonic	<u>Line to Line</u>		<u>Line to Neutral</u>	
	<u>No load</u>	<u>Full load</u>	<u>No load</u>	<u>Full load</u>
3	0.0	0.1	0.2	1.1
5	0.9	0.9	0.9	0.9
7	0.7	2.2	0.7	2.2
9	0.0	0.0	0.7	1.2
11	0.0	0.2	0.1	0.2
13	0.1	0.1	0.0	0.1
15	0.0	0.0	0.2	0.4



Cooling System Data

C200D6D

High Ambient Air Temperature Radiator Cooling System

	Fuel Type	Duty	Rating (kW)	Max Cooling @ Air Flow Static Restriction, Unhoused (inches water/mm water)					Housed in Free Air, No Air Discharge Restriction		
				0.0/0.0	0.25/6.4	0.5/12.7	0.75/19.1	1.0/25.4	Weather	Sound Level 1	Sound Level 2
				Maximum allowable ambient temperature, degree C							
60 Hz	Diesel	Standby	200	50	50	49	47	44	49	47	44
		Prime	180	50	50	47	45	43	48	46	43

Notes:

1. Data shown are anticipated cooling performance for typical generator set.
2. Cooling data is based on 1000 ft (305 m) site test location.
3. Generator set power output may need to be reduced at high ambient conditions. Consult generator set data sheet for derate schedules.
4. Cooling performance may be reduced due to several factors including but not limited to: Incorrect installation, improper operation, fouling of the cooling system, and other site installation variables.



Alternator data sheet

Frame size: **UCDI274K**

Characteristics								
Weights:		Wound stator assembly:	454 kg	1001 lb				
		Rotor assembly:	273 kg	602 lb				
		Complete alternator:	727 kg	1603 lb				
Maximum speed:			2250 rpm					
Excitation current:		Full load:	2 Amps					
		No load:	0.50 Amps					
Insulation system:		Class H throughout						
1 Ø Ratings (1.0 power factor)		60 Hz (winding no)			50 Hz (winding no)			
(Based on specific temperature rise at 40 °C ambient temperature)		Double delta (311)		4 lead (06)	Double delta (311)			
		120/240		120/240	110-120/220-240			
125 °C rise ratings	kW/kVA	175/175		200/200	150/150			
105 °C rise ratings	kW/kVA	160/160		N/A	137/137			
					4 lead (05)			
					110-120/220-240			
					N/A			
					N/A			
3 Ø Ratings (0.8 power factor)		Upper broad range (311)			Broad range (311)			
(Based on specified temperature rise at 40 °C ambient temperature)		120/208	127/220	139/240	110/190	115/200	120/208	127/220
		240/416	255/440	277/480	220/380	230/400	240/415	254/440
150 °C Rise ratings	kW	243	250	265	212	212	212	N/A
	kVA	304	313	331	265	265	265	N/A
125 °C Rise ratings	kW	233	239	250	200	200	200	N/A
	kVA	291	199	313	250	250	250	N/A
105 °C Rise ratings	kW	214	220	229	183	183	183	N/A
	kVA	267	275	286	229	229	229	N/A
80 °C Rise ratings	kW	N/A	N/A	N/A	N/A	N/A	N/A	N/A
	kVA	N/A	N/A	N/A	N/A	N/A	N/A	N/A
3 Ø Reactances (per unit, ±10%)								
(Based on full load at 105 °C rise rating)								
Synchronous		2.90	2.67	2.34	2.59	2.34	2.17	N/A
Transient		0.14	0.12	0.11	0.12	0.11	0.10	N/A
Subtransient		0.09	0.08	0.07	0.08	0.07	0.07	N/A
Negative sequence		0.12	0.11	0.10	0.11	0.10	0.09	N/A
Zero sequence		0.02	0.02	0.02	0.02	0.02	0.02	N/A
3 Ø Motor starting		Broad range		LBR*	600	Broad range		
Maximum kVA	(Shunt)	770				535		
(90% sustained voltage)	(PMG)	920				678		
Time constants (Sec)								
Transient		0.049			0.049			
Subtransient		0.020			0.020			
Open circuit		1.270			1.270			
DC		0.018			0.018			
Windings (@ 20° C)								
Stator resistance	(Line to Line, Ohms)	0.0126			0.0126			
Rotor resistance	(Ohms)	2.0800			2.0800			
Number of leads		12			12			

* Lower broad range 110/190 thru 120/208, 220/380 thru 240/416.



Alternator data sheet

Frame size: UCDI274K

Locked Rotor Motor Starting Curve (Winding 311)

**50
Hz**

MX

SX

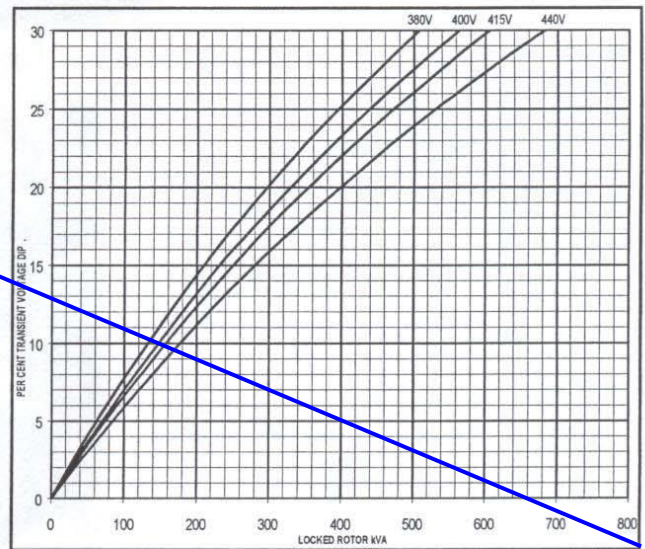
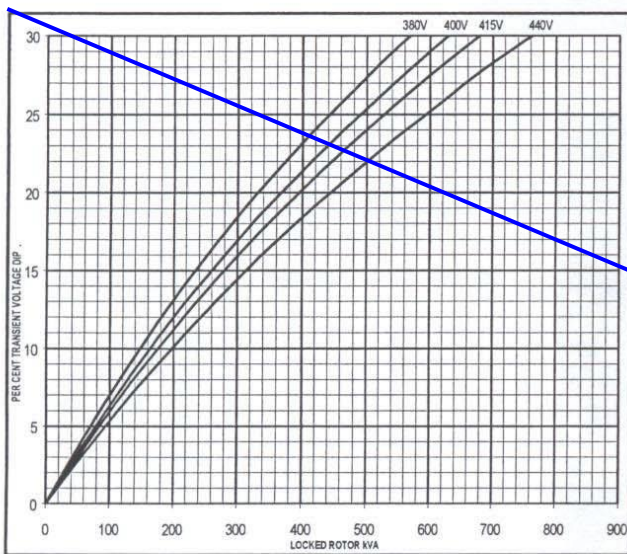

**60
Hz**

MX

SX

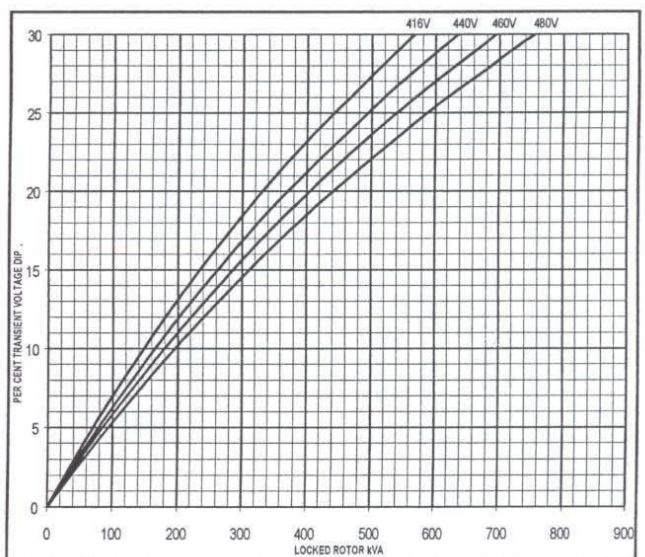
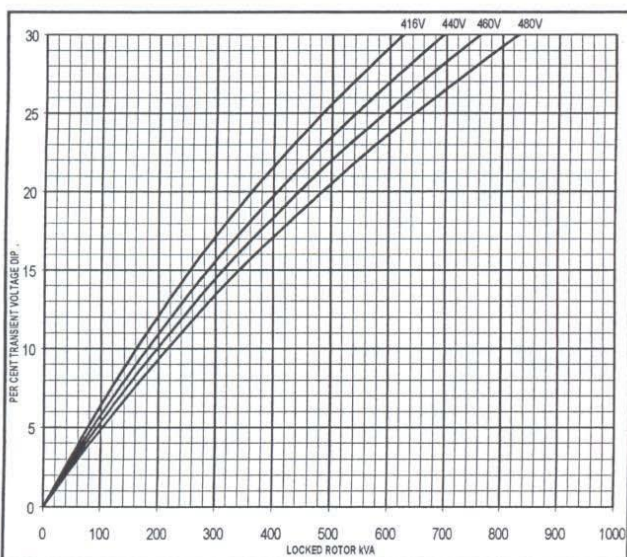



Alternator data sheet

Frame size: UCDI274K

Three-phase Short Circuit Decrement Curve. No-load Excitation at Rated Speed
Based on star (wye) connection.

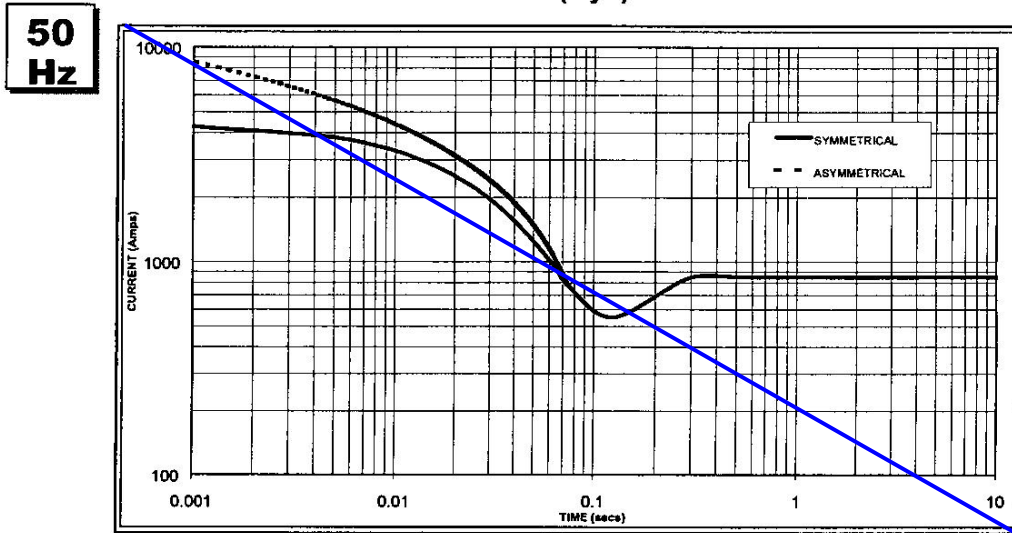

Sustained Short Circuit = 850 Amps

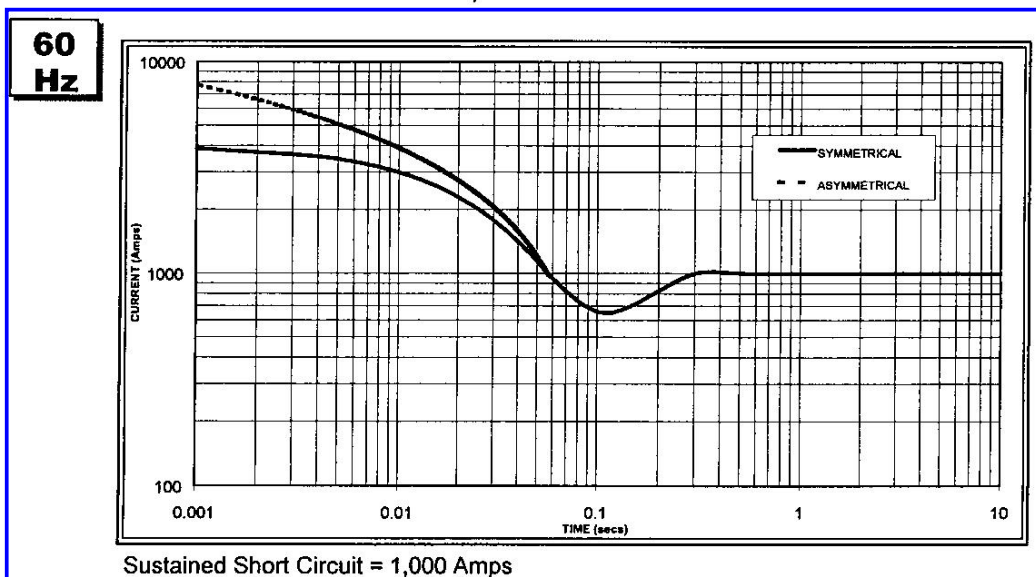

Sustained Short Circuit = 1,000 Amps

Note 1

The following multiplication factors should be used to adjust the values from curve between time 0.001 seconds and the minimum current point in respect of nominal operating voltage :

50Hz		60Hz	
Voltage	Factor	Voltage	Factor
380v	X 1.00	416v	X 1.00
400v	X 1.05	440v	X 1.07
415v	X 1.10	460v	X 1.12
440v	X 1.16	480v	X 1.16

The sustained current value is constant irrespective of voltage level

Note 2

The following multiplication factor should be used to convert the values calculated in accordance with NOTE 1 to those applicable to the various types of short circuit :

	3-phase	2-phase L-L	1-phase L-N
Instantaneous	x 1.00	x 0.87	x 1.30
Minimum	x 1.00	x 1.80	x 3.20
Sustained	x 1.00	x 1.50	x 2.50
Max. sustained duration	10 sec.	5 sec.	2 sec.

All other times are unchanged

Note 3

Curves are drawn for Star (Wye) connected machines. For other connection the following multipliers should be applied to current values as shown :

Parallel Star = Curve current value X 2

Series Delta = Curve current value X 1.732

SECTION 3

Generator Accessories





Battery Charger-6 Amp

A045D925 60Hz/50Hz



Description

Cummins® fully automatic battery chargers are designed to both recharge your batteries, and extend your battery's life in applications where it is stored for long periods of time. This charger can handle poor power quality, exposure to extreme weather and rough handling.

To maximize battery life, a 3-stage charging cycle is implemented. The three charging stages are bulk stage, absorption stage and maintenance stage. During the bulk stage, the charger uses its full amp output to do the heaviest charging, quickly bringing your battery to about 75% of capacity. In the absorption stage, the current slows, adjusting for maximum charging efficiency while it gently tops off the battery to about 98% of capacity.

During the maintenance stage, a lower, closely-regulated, constant voltage is applied to maintain full charge and prevent discharge.

Unlike some "trickle chargers," the float charger won't apply more current than necessary to maintain full charge. Batteries can be connected indefinitely, without harm; in fact, the float charge extends battery life.

Features

Protection – Surge protected to IEEE and EN standards. All models include single pole cartridge type fuses mounted on the printed circuit board to protect against input or output overcurrent.

Lightweight and Silent – Lighter than transformer types, completely silent but still provides full output when overloaded outlets drop AC voltage below the normal 115V.

Monitoring – Status LED indicators are provided to show the condition or charging status of the battery. When the red LED is on, it indicates that the battery is discharged and is recharging at the 'BULK' rate. When both the red and green LEDs are on, the battery is charging at the 'midrange' rate. When the green LED is on, the battery is 90% charged and ready for use.

Construction – Made using epoxy-potted cases making it the ultimate in durability, completely waterproof and able to withstand numerous caustic chemicals and gases, as well as being shockproof.

Fault Indication – The charger senses and indicates the following fault conditions: Defective or damaged cells, under-voltage at the battery, battery drawing more current than charger can replace, loss of power or extremely low AC voltage at the charger, other battery fault conditions and charger failure.

Compatibility – Works with Sealed Lead Acid (SLA), Absorbed Glass Mat (AGM) and Gel type batteries.

Low Electromagnetic and Radio

Frequency Interference – This product meets FCC class B for conducted and radiated emissions.

Listed – This product is UL listed according to the UL 1236 Standard.

Warranty – This product has a two year warranty

Specifications

Performance and Physical Characteristics

Output:	Nominal voltage	12 VDC
	Float voltage – 12 V batteries	13.0-13.6 VDC at 0-2 amps
	Maximum output current	6 A @ 12 VDC nom
Input:	Voltage AC	115, 208, 240 ±10%, 90-135
	Frequency	60 Hz ±5%
Battery:	Maximum battery size	150 Amp Hours
	Maximum recharge time	20 hours
Approximate net weight		4 lbs. (1.81 Kg)
Approximate dimensions: height x width x depth-in(mm)		2.25 x 6.4 x 3.5 (57 x 162 x 89)
Ambient temperature operation: At full rated output		-40°F to 122 °F (-40 °C to 50 °C)



Warning: Back feed to a utility system can cause electrocution and/or property damage. Do not connect generator sets to any building electrical system except through an approved device or after building main switch is open.

Warning: For professional use only. Must be installed by a qualified service technician. Improper installation presents hazards of electrical shock and improper operation, resulting in severe personal injury and/or property damage.

For more information contact your local Cummins distributor
or visit power.cummins.com

Our energy working for you.™



Product data sheet

Specifications

SQUARE D

Green Premium™



Circuit breaker, PowerPact L, unit mount, Micrologic 3.3S, 600A, 3 pole, 18kA, 600VAC,

LGL36600U33X

Main

Range	PowerPact
Product name	PowerPact L
Device short name	L-Frame
Product or Component Type	Circuit breaker
Device application	Distribution

Complementary

Line Rated Current	600 A
Number of Poles	3P
Control type	Toggle
Breaking capacity code	G
Breaking capacity	65 kA 240 V AC 50/60 Hz UL 489 35 kA 480 V AC 50/60 Hz UL 489 18 kA 600 V AC 50/60 Hz UL 489 20 kA 250 V DC UL 489 20 kA 500 V DC UL 489
[Ue] rated operational voltage	600 V AC 50/60 Hz IEC 60947-3
Network Frequency	50/60 Hz
[Ics] rated service breaking capacity	65 kA 220/240 V AC 50/60 Hz IEC 60947-2 35 kA 380/440/415 V AC 50/60 Hz IEC 60947-2 18 kA 500/525 V AC 50/60 Hz IEC 60947-2 20 kA 250 V DC IEC 60947-2 20 kA 500 V DC IEC 60947-2
[Uimp] rated impulse withstand voltage	8 kV IEC 60947-2
Trip unit technology	Electronic, standard, Micrologic 3.3 S, LSI
[Ui] rated insulation voltage	750 V IEC 60947-2
Trip unit name	Micrologic 3.3 S
Protection technology	Current limiter
Suitability for isolation	Yes IEC 60947-2
Utilisation category	Category A
AWG gauge	Please see CB outline drawing for lug and termination details

Local signalling	Ready 1 LED green) Alarm 1 LED 90 % Ir orange) Alarm LED 105 % Ir red) Switched off (OFF) 1 trip indicator green)
Mounting mode	Unit mount lug)
Mounting Support	Lug
Electrical connection	Lugs line Lugs load
Terminal identifier	Please see CB outline drawing for lug and termination details
Long time pick-up adjustment range	0.25...1 x In
Tightening torque	442.54 lbf.in (50 N.m) 0.11...0.37 in ² (70...240 mm ²) (AWG 2/0...500 kcmil)
Number of slots	2 auxiliary switch OF plug-in) 1 alarm switch SD plug-in) 1 overcurrent trip switch SDE plug-in) 1 voltage release MN or MX plug-in)
Power wire stripping length	1.22 in (31 mm) 2.40 in (61 mm)
Color	Black
Height	13.39 in (340 mm)
Width	5.51 in (140 mm)
Depth	4.33 in (110 mm)
Net weight	13.67 lb(US) (6.2 kg)
Communication interface	Modbus Ethernet

Environment

Standards	UL CSA NEMA NOM-003-SCFI-2000 IEC 60947-2
Product certifications	UL CSA NOM
IP degree of protection	Front cover IP40
Pollution degree	3 IEC 60947-1
Ambient Air Temperature for Operation	28...158 °F (-2...70 °C)
Ambient Air Temperature for Storage	-58...185 °F (-50...85 °C)
Operating altitude	< 6561.68 ft (2000 m) without derating 5000 m with derating

Ordering and shipping details

Category	01116-L ELEC TRIP UNIT MOUNT BREAKER/SW
Discount Schedule	DE2
GTIN	785901638674
Nbr. of units in pkg.	1
Package weight(Lbs)	15.00 lb(US) (6.804 kg)
Returnability	Yes
Country of origin	US

Packing Units

Unit Type of Package 1	PCE
Package 1 Height	8.75 in (22.225 cm)
Package 1 width	10.75 in (27.305 cm)
Package 1 Length	19.50 in (49.53 cm)

Offer Sustainability

Sustainable offer status	Green Premium product
California proposition 65	WARNING: This product can expose you to chemicals including: DINP, which is known to the State of California to cause cancer, and DIDP, which is known to the State of California to cause birth defects or other reproductive harm. For more information go to www.P65Warnings.ca.gov
REACH Regulation	REACH Declaration
EU RoHS Directive	Compliant EU RoHS Declaration
Mercury free	Yes
RoHS exemption information	Yes
China RoHS Regulation	China RoHS declaration Product out of China RoHS scope. Substance declaration for your information.
Environmental Disclosure	Product Environmental Profile
Circularity Profile	End of Life Information
PVC free	Yes

Dimensions

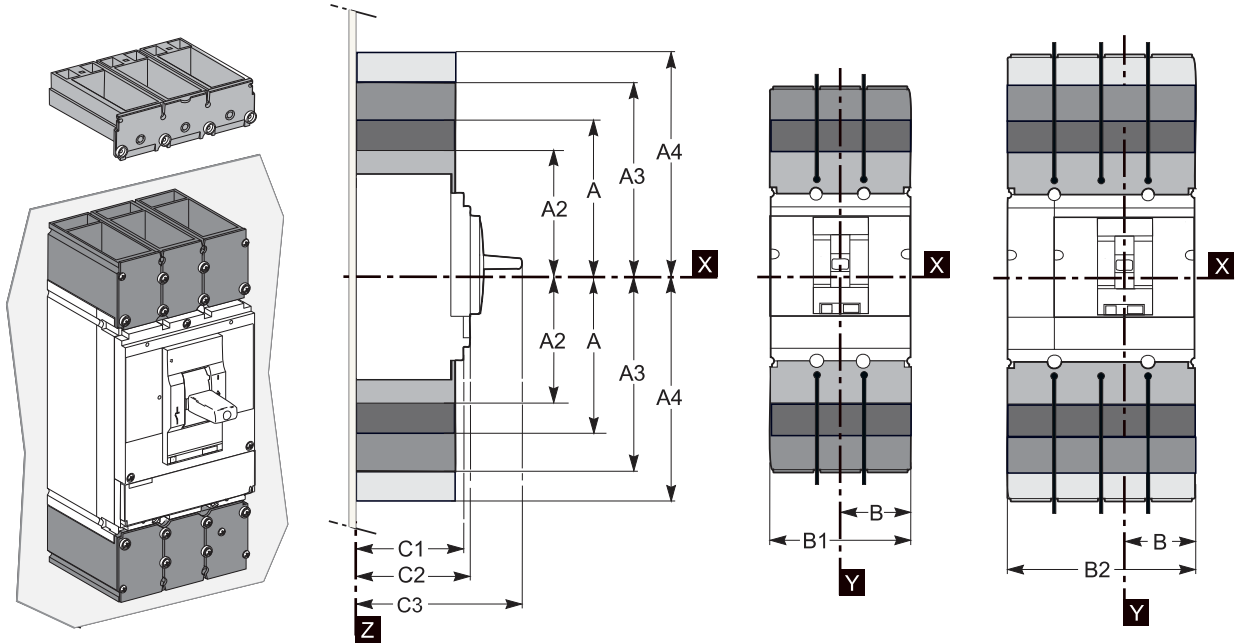

A2 = Short Lug Pack
 AL400L61K3
 CU400L61K3
 AL600LF52K3
 CU600LF5283

A = Medium Lug Pack
 AL400L61K4
 CU400L61K4
 AL600LS52K3
 AL600LS52K4
 CU600LS52K3
 CU600LS52K4

A3 = Long Lug Pack
 Compression Lug Kits
 A4 = 500 Vdc Lug Pack

L-Frame

	A	A2	A3	A4	B	B1	B2	C1	C2	C3
inch	6.69	5.65	7.87	9.53	2.76	5.51	7.28	3.76	4.33	6.61
mm	170	143.5	200	242	70	140	185	105	110	168

Please see CB outline drawing for lug and termination details

PowerPact™ H-, J-, and L-Frame Circuit Breakers Trip Units

Micrologic™ 3 Trip Units

Micrologic 3 trip units can be used on PowerPact H-, J-, and L-Frame circuit breakers with performance levels D/G/J/L.

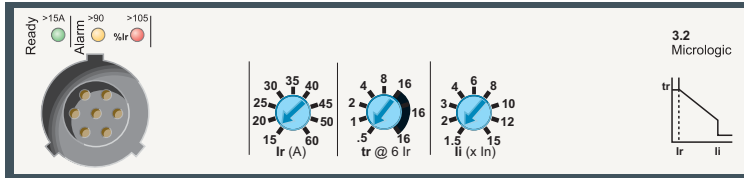

They provide:

- standard protection of distribution cables
- indication of:
 - overloads (using LEDs)
 - overload tripping (using the SDx relay module).

Circuit breakers equipped with Micrologic 3 trip units can be used to protect distribution systems supplied by transformers.

Protection

Settings are made using the adjustment rotary switches.

Overloads: Long time protection (I_r)

Inverse time protection against overloads with an adjustable current pick-up I_r set using a rotary switch and an adjustable time delay t_r .

Neutral protection

- On 3-pole L-frame circuit breakers, neutral protection is not possible.
- On four-pole L-frame circuit breakers, neutral protection may be set using a three-position switch:
 - switch position 4P 3D: neutral unprotected
 - switch position 4P 3D + N/2: neutral protection at half the value of the phase pick-up, ($0.5 \times I_r$)
 - switch position 4P 4D: neutral fully protected at I_r

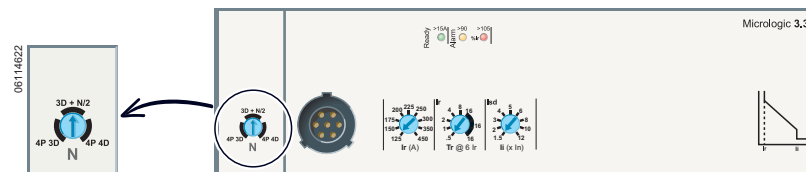

Indicators

Front indicators

- The green “Ready” LED blinks slowly when the electronic trip unit is ready to provide protection. It indicates the trip unit is operating correctly.
- Orange overload pre-alarm LED: steady on when $I > 90\% I_r$
- Red overload LED: steady on when $I > 105\% I_r$

Remote indicators

An overload trip signal can be remotely checked by installing an SDx relay module inside the circuit breaker. This module receives the signal from the Micrologic electronic trip unit through an optical link and makes it available on the terminal block. The signal is cleared when the circuit breaker is reclosed. See page 94.

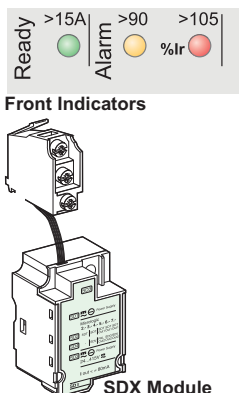

PowerPact™ H-, J-, and L-Frame Circuit Breakers Trip Units

Table 50: Micrologic™ 3 Trip Unit

Ratings	I_n at 104°F (40°C) ¹		60 A	100 A	150 A	250 A	400 A	600 A
Circuit Breaker	H-frame		X	X	X			
	J-frame					X		
	L-frame					X	X	X

Micrologic 3.2 / 3.3 trip units

L Long-time protection

	I_r		Value depending on sensor rating (I_n) and setting on rotary switch									
	Pick-Up (A) Tripping between 1.05 and 1.20 I_r	$I_n = 60$ A	$I_r =$	15	20	25	30	35	40	45	50	60
$I_n = 100$ A		$I_r =$	35	40	45	50	60	70	80	90	100	
$I_n = 150$ A		$I_r =$	50	60	70	80	90	100	110	125	150	
$I_n = 250$ A		$I_r =$	70	80	100	125	150	175	200	225	250	
$I_n = 400$ A		$I_r =$	125	150	175	200	225	250	300	350	400	
$I_n = 600$ A		$I_r =$	200	225	250	300	350	400	450	500	600	
Time Delay (s) Accuracy 0 to -20%	t_r		0.5	1	2	4	8	16				
		$1.5 \times I_r$	15	25	50	100	200	400				
		$6 \times I_r$	0.5	1	2	4	8	16				
		$7.2 \times I_r$	0.35	0.7	1.4	2.8	5.5	11				
Thermal memory			20 minutes before and after tripping									

I Instantaneous

Pick-up (A) accuracy \pm 15%	$I_i \times$	60 A	1.5	2	3	4	6	8	10	12	15
		100 A	1.5	2	3	4	6	8	10	12	15
		150 A	1.5	2	3	4	6	8	10	12	15
		250 A	1.5	2	3	4	5	6	8	10	12
		400 A	1.5	2	3	4	5	6	8	10	12
		600 A	1.5	2	3	4	5	6	8	10	11
	Non-tripping time Maximum break time		10 ms 50 ms for $I > 1.5 I_i$								

Micrologic 3.2S / 3.3S trip units

L Long-time protection

	I_r		Value depending on sensor rating (I_n) and setting on rotary switch									
	Pick-Up (A) Tripping between 1.05 and 1.20 I_r	$I_n = 60$ A	$I_r =$	15	20	25	30	35	40	45	50	60
$I_n = 100$ A		$I_r =$	35	40	45	50	60	70	80	90	100	
$I_n = 150$ A		$I_r =$	50	60	70	80	90	100	110	125	150	
$I_n = 250$ A		$I_r =$	70	80	100	125	150	175	200	225	250	
$I_n = 400$ A		$I_r =$	125	150	175	200	225	250	300	350	400	
$I_n = 600$ A		$I_r =$	200	225	250	300	350	400	450	500	600	
Time Delay (s) Accuracy 0 to -20%	t_r		non-adjustable									
		$1.5 \times I_r$	400									
		$6 \times I_r$	16									
		$7.2 \times I_r$	11									
Thermal memory			20 minutes before and after tripping									

S Short-time protection

Pick-up (A) accuracy \pm 10%	$I_{sd} - I_r \times \dots$		1.5	2	3	4	5	6	7	8	10	
Time delay (ms)	t_{sd}		non-adjustable									
	Non-tripping time Maximum break time		20 80									

I Instantaneous

Pick-up (A) accuracy \pm 15%	$I_i \times I_n$		1.5	2	3	4	6	8	10	12	15
	Non-tripping time Maximum break time		10 ms 50 ms for $I > 1.5 I_i$								

¹ If the trip units are used in high-temperature environments, the Micrologic trip unit setting must take into account the thermal limitations of the circuit breaker. See the temperature derating information on page 126.

PowerPact H-, J-, and L-Frame Circuit Breakers Trip Curves

Figure 125: Micrologic 3.3S and 3.3S-W Electronic Trip Unit Long Time/Short Time Trip Curve

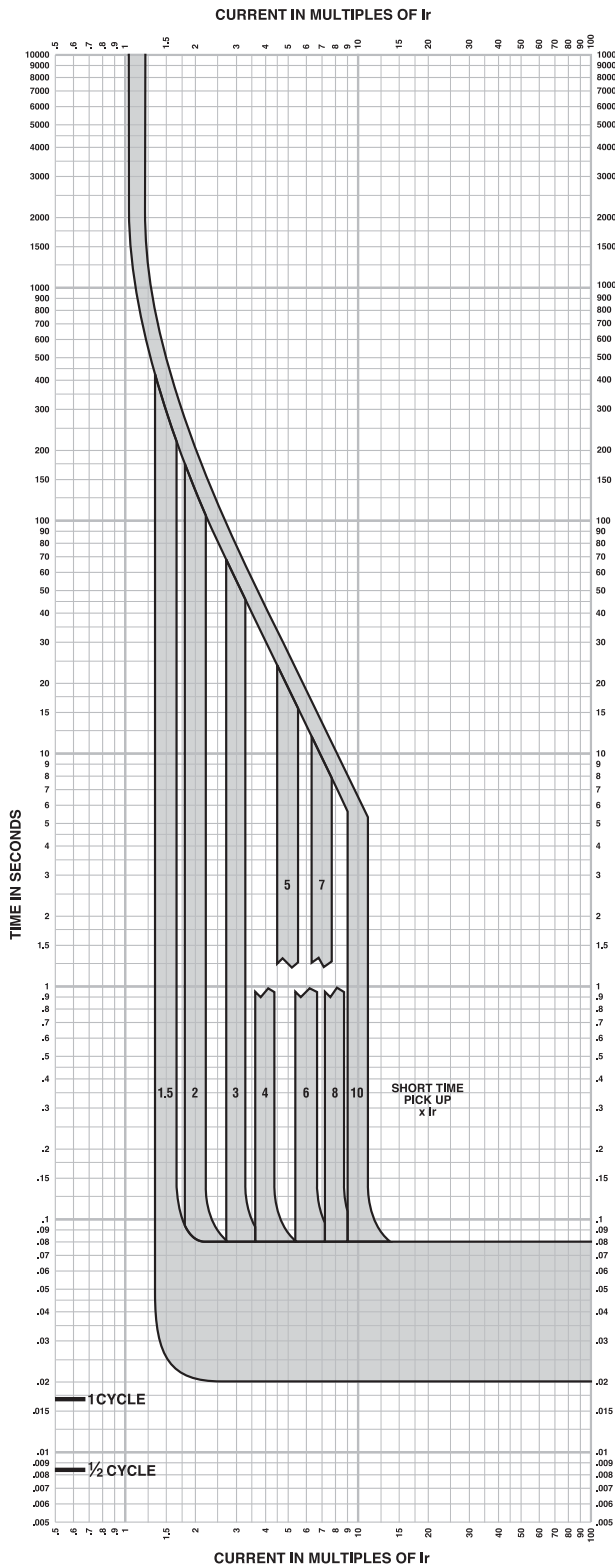

MICROLOGIC™ ELECTRONIC TRIP UNITS Micrologic™ 3.3S and 3.3S-W Long Time/Short Time Trip Curve 600A L-Frame

The time-current curve information is to be used for application and coordination purposes only.

Notes:

1. There is a thermal-imaging effect that can act to shorten the long-time delay. The thermal imaging effect comes into play if a current above the long-time delay pickup value exists for a time and then is cleared by the tripping of a downstream device or the circuit breaker itself. A subsequent overload will cause the circuit breaker to trip in a shorter time than normal. The amount of time delay reduction is inverse to the amount of time that has elapsed since the previous overload. Approximately 20 minutes is required between overloads to completely reset thermal-imaging.
2. Total clearing times shown include the response times of the trip unit, the circuit breaker opening, and the extinction of the current.

Curves apply from -35°C to +70°C (-31°F to +158°F) ambient temperature.

MULTIPLES OF I_n

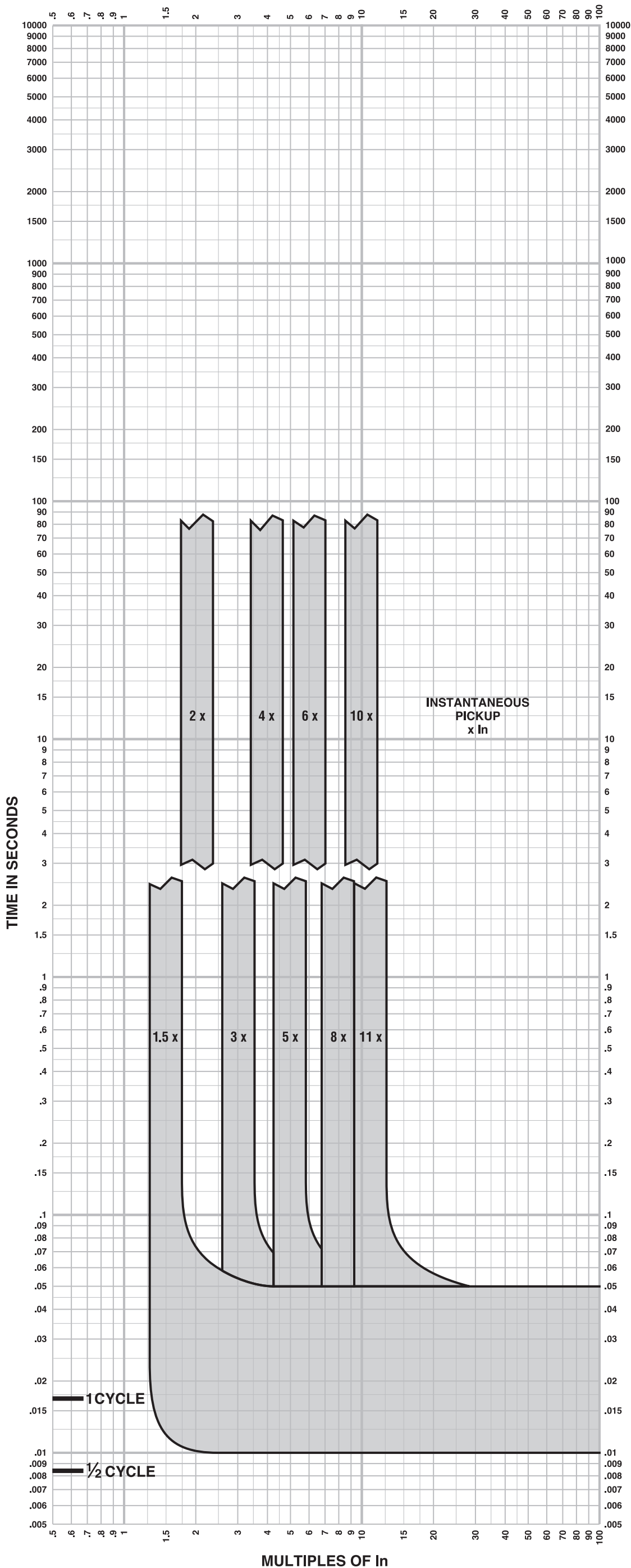

MICROLOGIC™ ELECTRONIC TRIP UNITS
Micrologic™ 3.3/3.3S/5.3A or E/6.3A or E
Instantaneous Trip Curve
600A L-Frame

The time-current curve information is to be used for application and coordination purposes only.

Notes:

1. There is a thermal-imaging effect that can act to shorten the long-time delay. The thermal imaging effect comes into play if a current above the long-time delay pickup value exists for a time and then is cleared by the tripping of a downstream device or the circuit breaker itself. A subsequent overload will cause the circuit breaker to trip in a shorter time than normal. The amount of time delay reduction is inverse to the amount of time that has elapsed since the previous overload. Approximately 20 minutes is required between overloads to completely reset thermal-imaging.
2. Total clearing times shown include the response times of the trip unit, the circuit breaker opening, and the extinction of the current.
3. I_n = Maximum dial setting of I_r .
 600A L-Frame: I_n = 600A = Max I_r setting
 Curves apply from -35°C to $+70^{\circ}\text{C}$ (-31°F to $+158^{\circ}\text{F}$) ambient temperature.

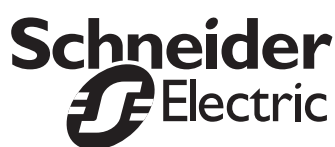

REL NO	REV	NO	REVISION	DWN	CKD	APVD	DATE
ECO-182895	A	1	PRODUCTION RELEASE	DAH	DAH	GILLETT	30 JAN 18

NOTE:

- 1. TORQUE TO 6 - 8 Nm.
- 2. HARDWARE IN THIS LOCATION FOR HOLDING DUCT PIECES TOGETHER.

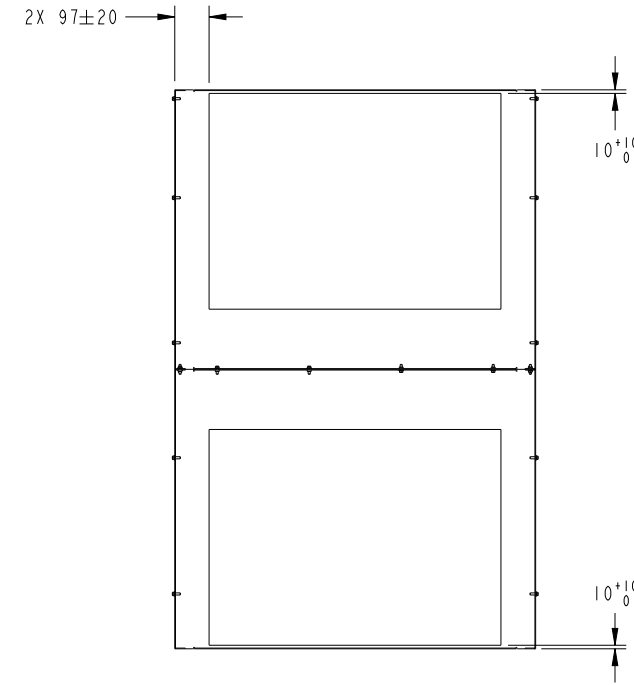

INSULATION ATTACHED TO PART A062J646

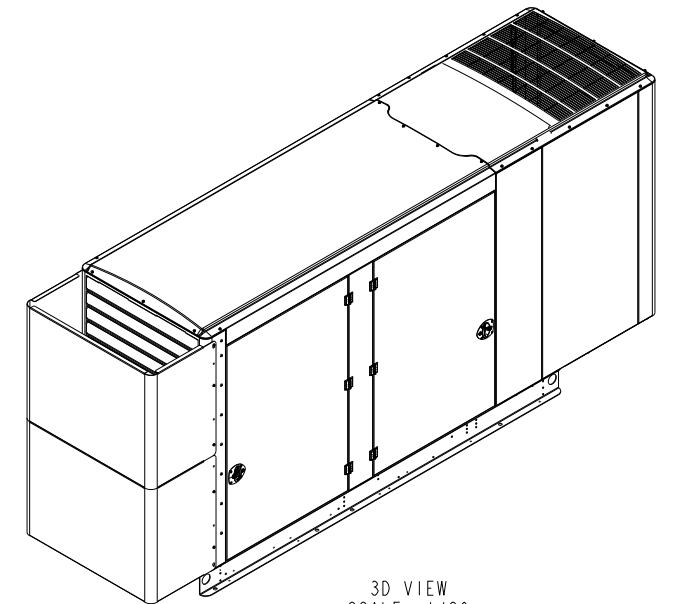
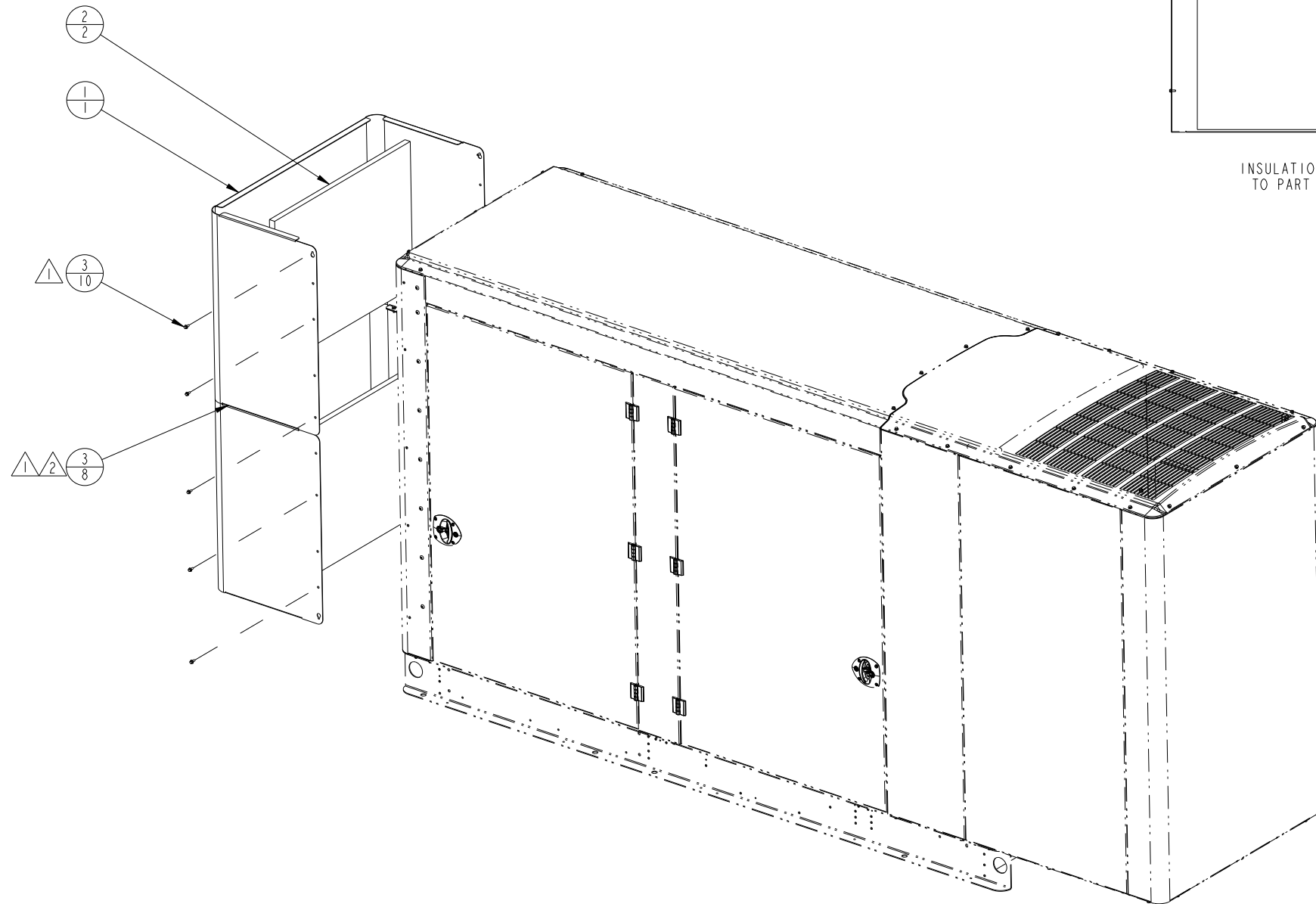

UNLESS OTHERWISE SPECIFIED, ALL DIMENSIONS ARE IN MILLIMETERS		SHW TO A054F439	DWN D HOFMEISTER		CUMMINS POWER GENERATION
DO NOT SCALE PRINT			CKD D HOFMEISTER		INSTALLATION, ENCLOSURE
DIM	TOL		APVD D GILLETT	SITE CODE	
X ± 1	0.00 - 4.99 +0.15/-0.08		DATE 30 JAN 18		
.X ± 0.8	5.00 - 9.99 +0.20/-0.10				
.XX ± 0.38	10.00 - 17.49 +0.25/-0.13				
	17.50 - 24.99 +0.30/-0.13				
ANG TOL	SCALE	THIS DOCUMENT (AND THE INFORMATION SHOWN THEREON) IS CONFIDENTIAL AND PROPRIETARY AND SHALL NOT BE DISCLOSED TO OTHERS IN HARD COPY OR ELECTRONIC FORM, REPRODUCED BY ANY MEANS, OR USED FOR ANY PURPOSE WITHOUT WRITTEN CONSENT OF CUMMINS INC.		FOR INTERPRETATION OF DIMENSIONING AND TOLERANCING, SEE ASME Y14.5-2009	FIRST USED ON
± 1.0°	1/10		ARROW	PGF	
				D	A062H155
					CAD SHEET 1 of 1

SECTION 4

Generator Drawings



REL NO	REV	NO	REVISION	DWN	CKD	APVD	DATE
ECO-176532	A	1	PRODUCTION RELEASE	DAH	DAH	GILLETT	04APR18

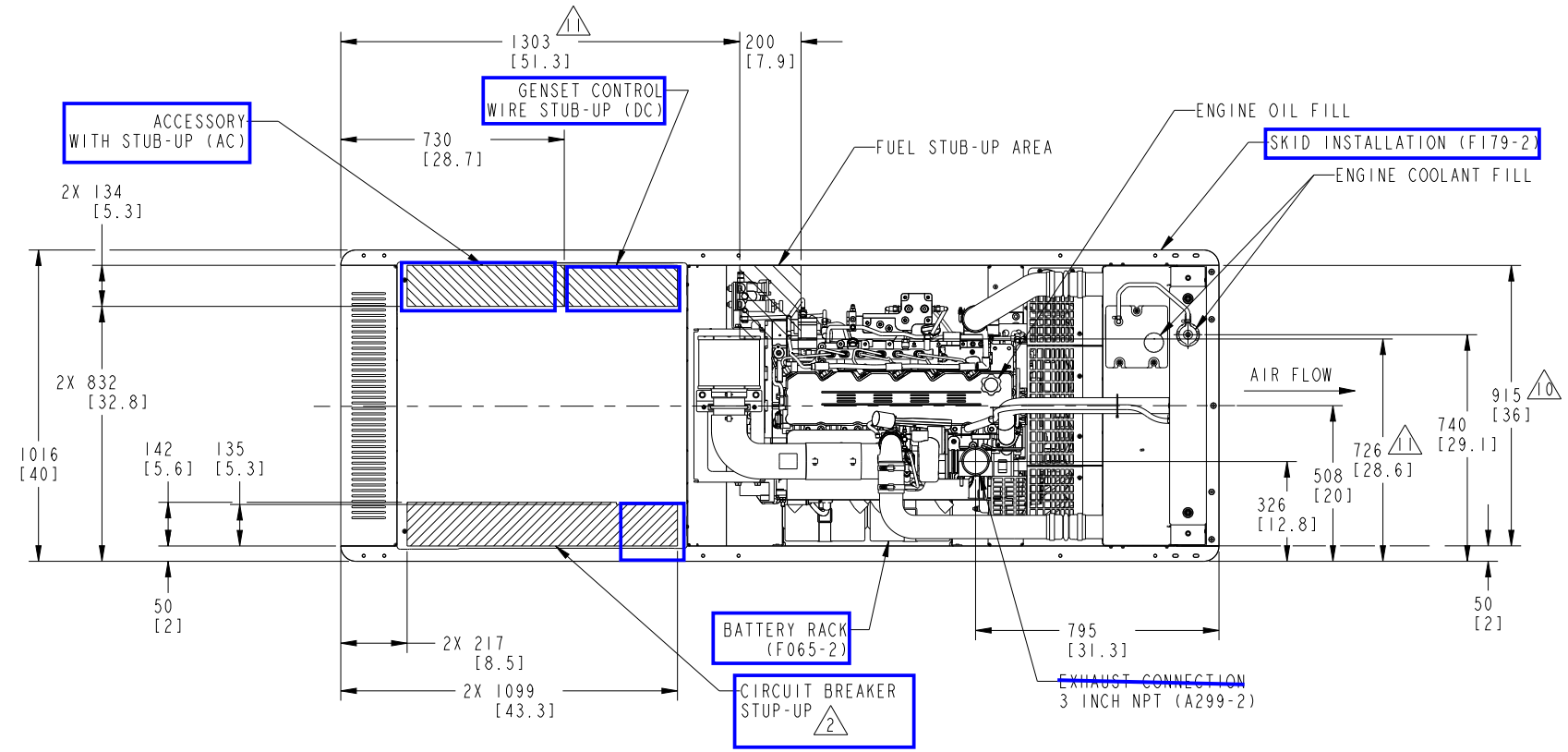

- NOTES:
- ALL DIMENSIONS ARE REFERENCE, UNLESS SPECIFICALLY TOLERANCED.
 - REFER TO CIRCUIT BREAKER OUTLINE DRAWING FOR ELECTRICAL STUB-UP AREA FOR SPECIFIC BREAKERS.
 - CONTROL INTERFACE CONNECTIONS SHOULD BE MADE WITH FLEXIBLE CONNECTIONS.
 - Ø21 [0.8] HOLES MARKED BY FOR SECURING TO MOUNTING SURFACE. HOLES IN GENERATOR SET BASE AT THESE LOCATIONS ARE INTENDED FOR ATTACHMENT TO THE MOUNTING SURFACE. IF GENERATOR SET IS MOUNTED ON A FUEL TANK, REFER TO FUEL TANK OUTLINE DRAWING FOR LOCATION OF TANK ATTACHMENT POINTS.
 - REFER TO GENSET OR FUEL TANK FOUNDATION OUTLINES FOR ELECTRICAL, FUEL AND OTHER FOUNDATION SPECIFICS.
 - GENSET SUPPLIED WITH FLEXIBLE FUEL LINES THAT CAN BE CONNECTED TO ENGINE INTERFACE POINTS.
 - FUEL SUPPLY LINE: 670 [26] LONG WITH 1/4 INCH NPT MALE TERMINATION.
 - FUEL RETURN LINE: 930 [37] LONG WITH 1/4 INCH NPT MALE TERMINATION.
 - OIL DRAIN EXTENSION: 5/8 INCH HOSE I.D.
 - FOR IBC SEISMIC CERTIFIED INSTALLATIONS, SEE GENSET IBC SEISMIC INSTALLATION REQUIREMENTS DRAWING.
 - DRY WEIGHT = WET WEIGHT - 38.5 KG (85 LB).
 - 6X Ø7.3 HOLES FOR CUSTOMER-SUPPLIED COOLING EXHAUST AIR DUCT ADAPTER.
 - FUEL SUPPLY AND RETURN STUB-UP AREA.

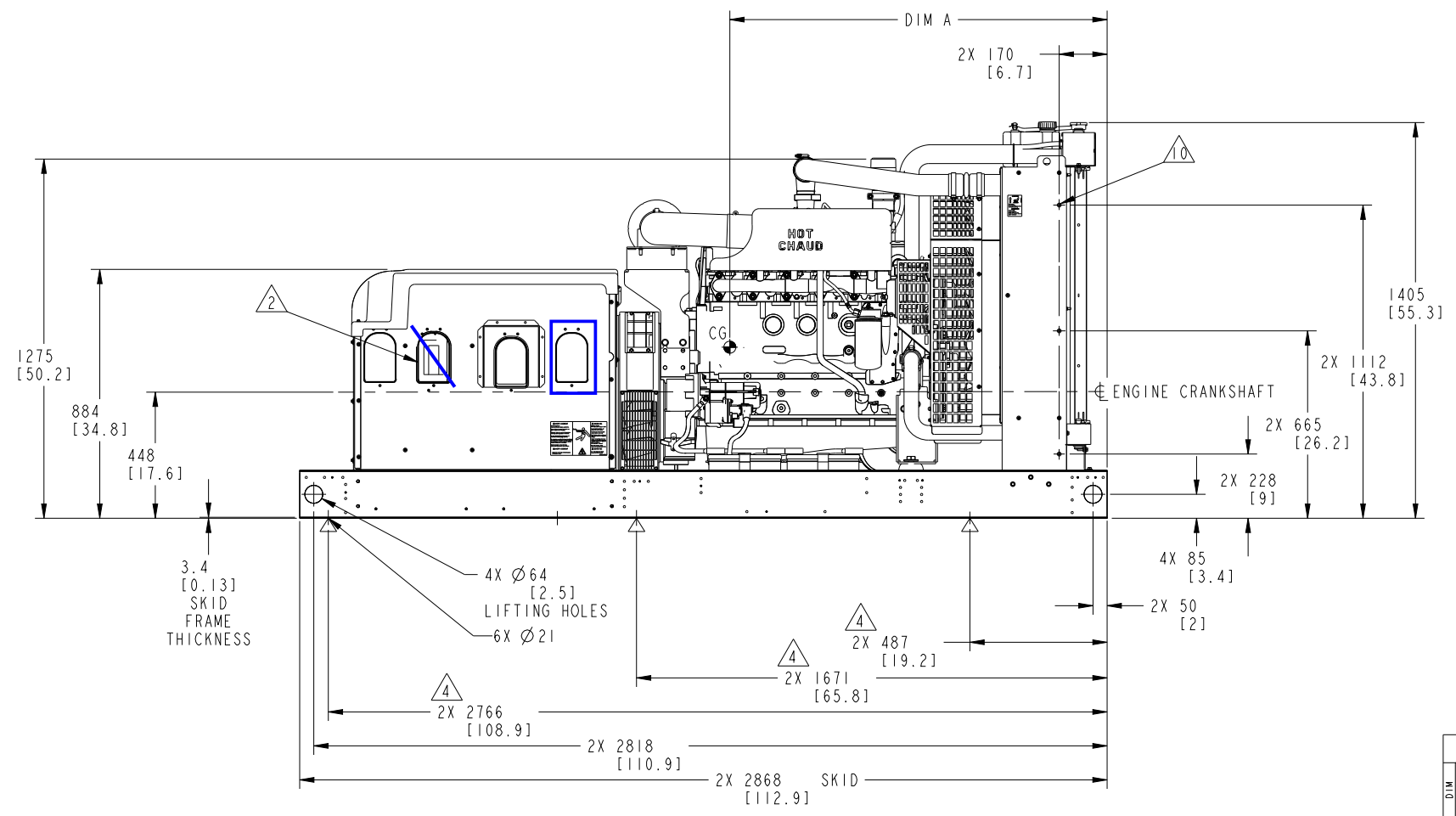

ALT DATA SHEET #	DIM A	DIM B	GENSET WET WEIGHT	
			KG	LB
ADS-208	1414	504	1340	2955
ADS-209	1443	502	1390	3064
ADS-210	1470	500	1442	3179
ADS-211	1493	499	1480	3262
ADS-212	1526	495	1583	3491
ADS-213	1526	495	1583	3491

C125D6D, C150D6D, C175D6D, **C200D6D**

UNLESS OTHERWISE SPECIFIED, ALL DIMENSIONS ARE IN MILLIMETERS		SKID TO	DWN D HOFMEISTER		CUMMINS POWER GENERATION	
DO NOT SCALE PRINT			CKD D HOFMEISTER		OUTLINE, GENSET	
DIM	TOLERANCE		DATE 04APR18	SITE CODE		
ANG TOL	SCALE	THIS DOCUMENT (AND THE INFORMATION SHOWN THEREON) IS CONFIDENTIAL AND PROPRIETARY AND SHALL NOT BE DISCLOSED TO OTHERS IN HARD COPY OR ELECTRONIC FORM, REPRODUCED BY ANY MEANS, OR USED FOR ANY PURPOSE WITHOUT WRITTEN CONSENT OF CUMMINS INC.	FIRST USED ON	PGF	A060C858	CAD SHEET 1 OF 2

REL NO	REV	NO	REVISION	DWN	CKD	APVD	DATE
ECO-176532	A	1	PRODUCTION RELEASE	DAH	DAH	GILLETT	04APR18

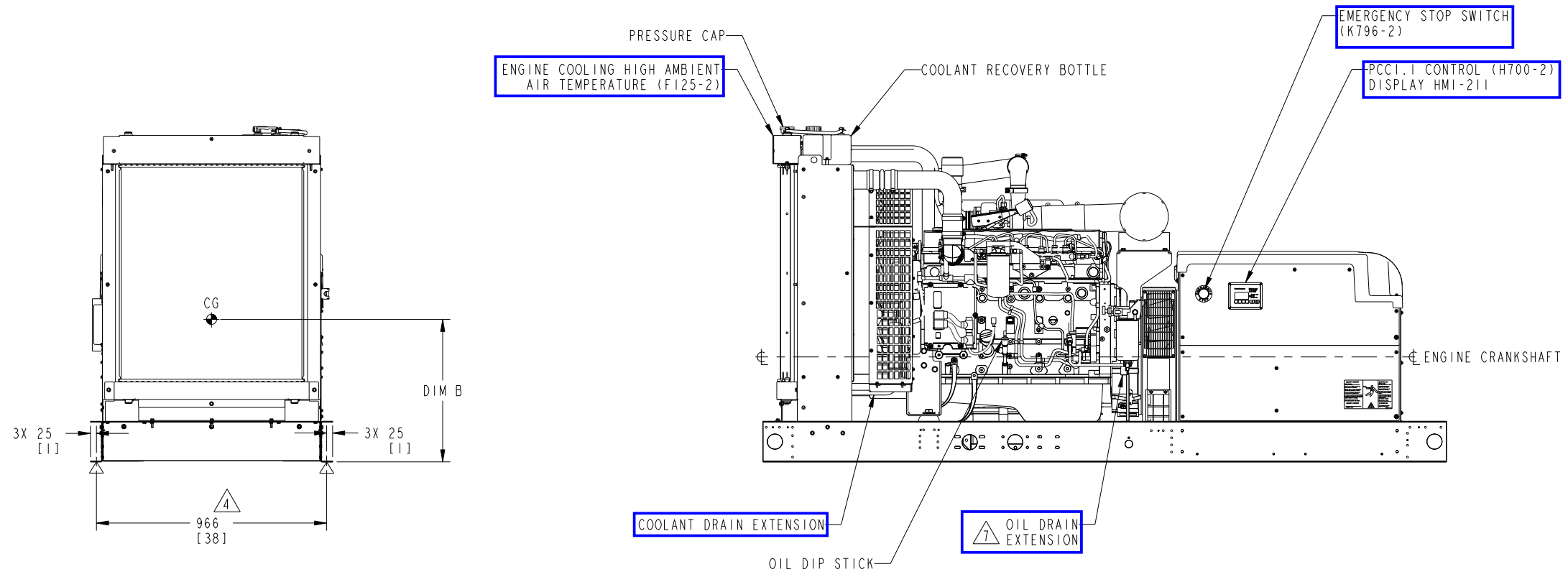

UNLESS OTHERWISE SPECIFIED, ALL DIMENSIONS ARE IN MILLIMETERS		SHW TO	DWN D HOFMEISTER		CUMMINS POWER GENERATION																											
DO NOT SCALE PRINT			CKD D HOFMEISTER		OUTLINE, GENSET																											
<table border="1"> <tr> <th>DIM</th> <th>TOL</th> </tr> <tr> <td>X ± 1</td> <td>0.00- 4.99 +0.15/-0.08</td> </tr> <tr> <td>.X ± 0.8</td> <td>5.00- 9.99 +0.20/-0.10</td> </tr> <tr> <td>.XX ± 0.38</td> <td>10.00-17.49 +0.25/-0.13</td> </tr> <tr> <td></td> <td>17.50-24.99 +0.30/-0.13</td> </tr> </table>	DIM	TOL	X ± 1	0.00- 4.99 +0.15/-0.08	.X ± 0.8	5.00- 9.99 +0.20/-0.10	.XX ± 0.38	10.00-17.49 +0.25/-0.13		17.50-24.99 +0.30/-0.13	<table border="1"> <tr> <th>ANG TOL</th> <th>SCALE</th> </tr> <tr> <td>± 1.0°</td> <td>3:32</td> </tr> </table>	ANG TOL	SCALE	± 1.0°	3:32	<small>THIS DOCUMENT (AND THE INFORMATION SHOWN THEREON) IS CONFIDENTIAL AND PROPRIETARY AND SHALL NOT BE DISCLOSED TO OTHERS IN HARD COPY OR ELECTRONIC FORM, REPRODUCED BY ANY MEANS, OR USED FOR ANY PURPOSE WITHOUT WRITTEN CONSENT OF CUMMINS INC.</small>		<table border="1"> <tr> <td>DATE 04APR18</td> <td>FIRST USED ON</td> </tr> <tr> <td></td> <td>ARROW</td> </tr> </table>	DATE 04APR18	FIRST USED ON		ARROW	<table border="1"> <tr> <td>SITE CODE</td> <td>PGF</td> </tr> <tr> <td>SCALE</td> <td>D</td> </tr> </table>	SITE CODE	PGF	SCALE	D	<table border="1"> <tr> <td>A060C858</td> <td>CAD SHEET</td> </tr> <tr> <td></td> <td>2 of 2</td> </tr> </table>	A060C858	CAD SHEET		2 of 2
DIM	TOL																															
X ± 1	0.00- 4.99 +0.15/-0.08																															
.X ± 0.8	5.00- 9.99 +0.20/-0.10																															
.XX ± 0.38	10.00-17.49 +0.25/-0.13																															
	17.50-24.99 +0.30/-0.13																															
ANG TOL	SCALE																															
± 1.0°	3:32																															
DATE 04APR18	FIRST USED ON																															
	ARROW																															
SITE CODE	PGF																															
SCALE	D																															
A060C858	CAD SHEET																															
	2 of 2																															

REL NO	REV NO	REVISION	DWN	CKD	APVD	DATE
ECO-176532	A	1 PRODUCTION RELEASE	DAH	DAH	GILLETT	10APR18

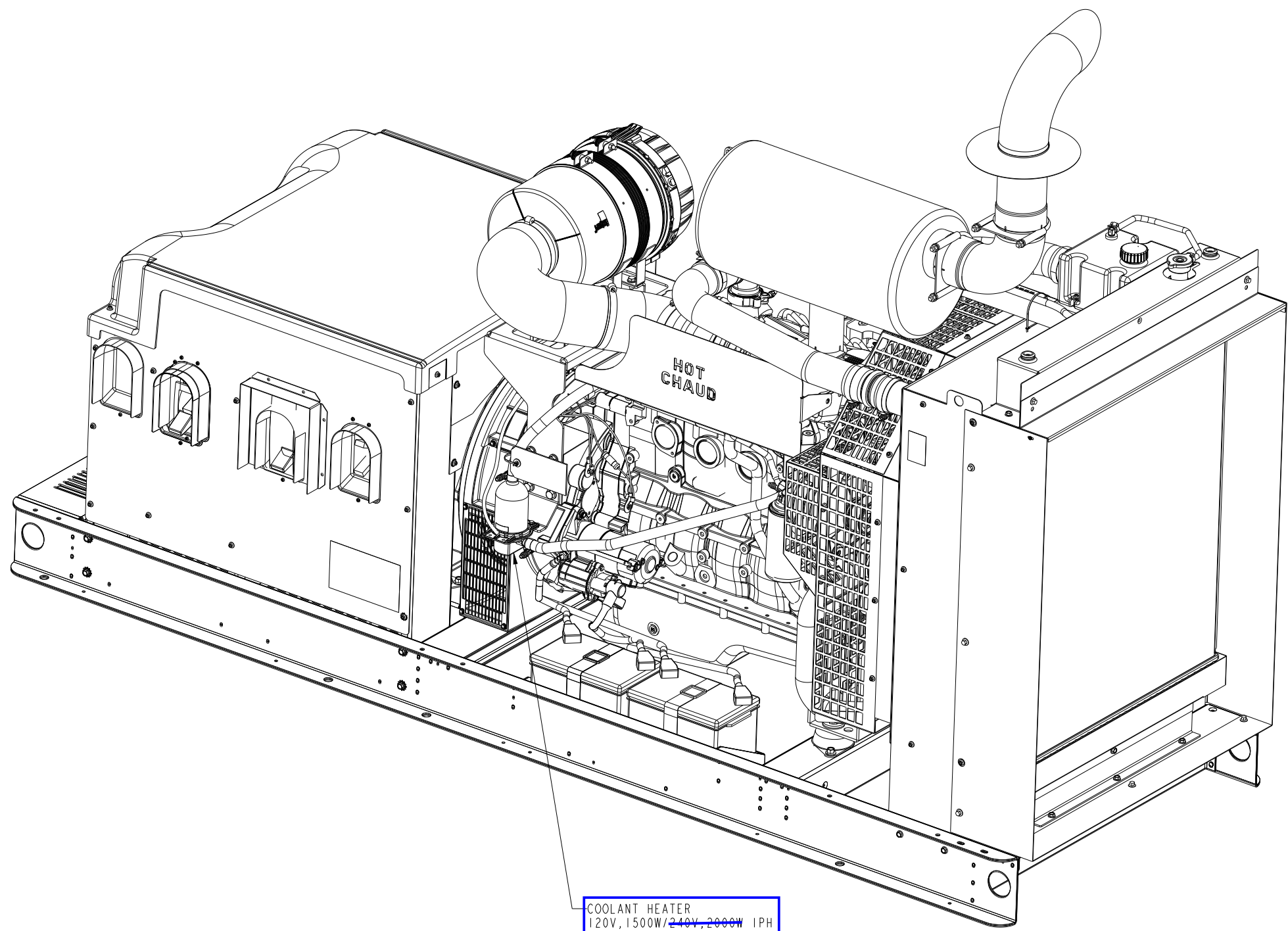

COOLANT HEATER
 120V, 1500W/240V, 2000W IPH
 (E153-2/E154-2)

UNLESS OTHERWISE SPECIFIED, ALL DIMENSIONS ARE IN MILLIMETERS		SHW TO A055J592	DWN D HOFMEISTER		CUMMINS POWER GENERATION
DO NOT SCALE PRINT		CKD D HOFMEISTER	APVD D GILLETT		
DIM	TOLERANCE	DATE 10APR18	FOR INTERPRETATION OF DIMENSIONING AND TOLERANCING, SEE ASME Y14.5-2009	SITE CODE	OUTLINE, GENSET OPTIONS
ANG TOL	SCALE	ARROW	FIRST USED ON	PGF	A060G756
± 1.0°	3:16				CAD SHEET 2 of 3

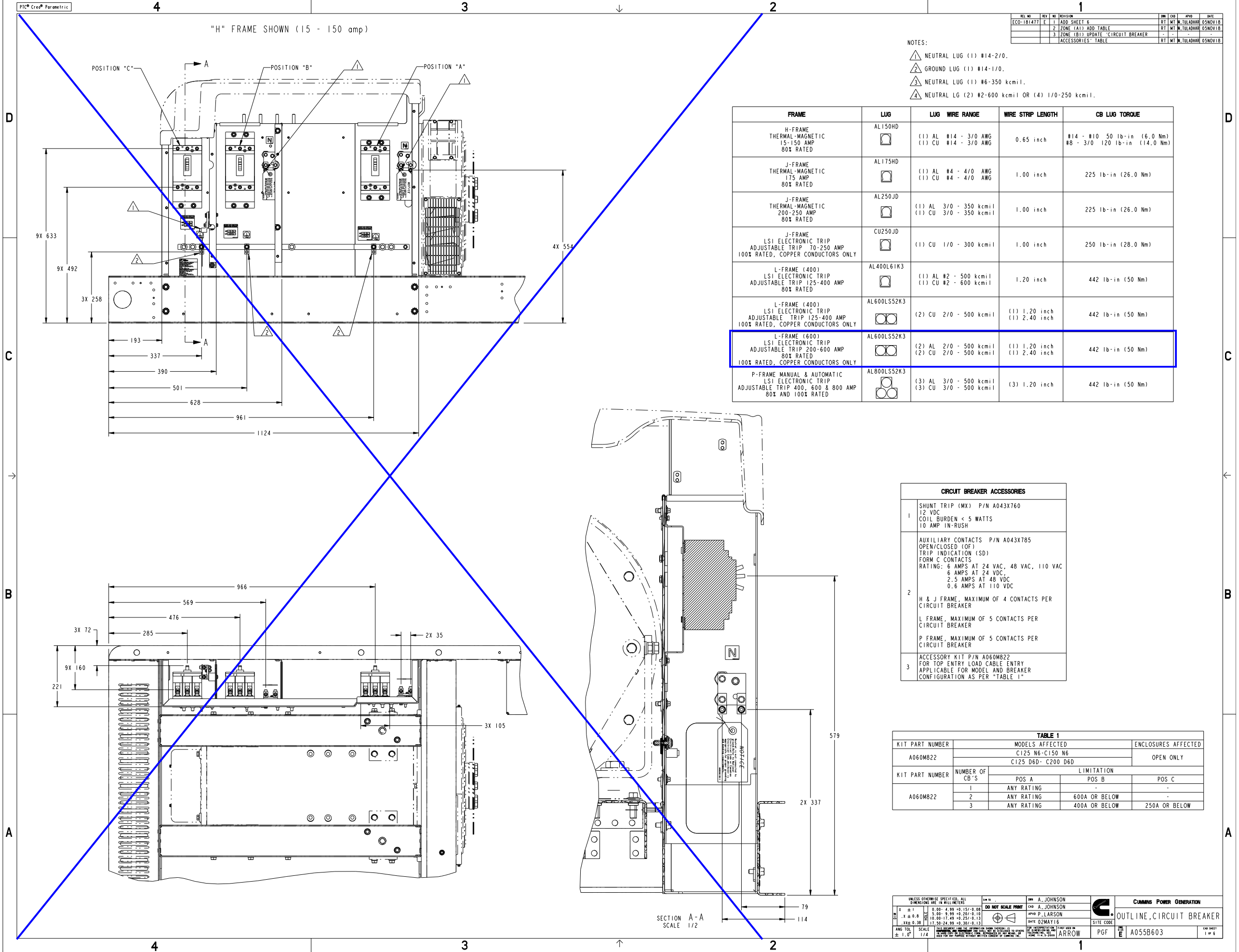

REV NO	REV	NO	REVISION	REV	NO	DATE
ECO-181477	E	1	ADD SHEET 6	RT	MT, M. TULADHAN	05NOV18
		2	ZONE (A1) ADD TABLE	RT	MT, M. TULADHAN	05NOV18
		3	ZONE (B1) UPDATE "CIRCUIT BREAKER ACCESSORIES" TABLE	RT	MT, M. TULADHAN	05NOV18

- NOTES:
- 1 NEUTRAL LUG (1) #14-2/0.
 - 2 GROUND LUG (1) #14-1/0.
 - 3 NEUTRAL LUG (1) #6-350 kcmil.
 - 4 NEUTRAL LG (2) #2-600 kcmil OR (4) 1/0-250 kcmil.

FRAME	LUG	LUG WIRE RANGE	WIRE STRIP LENGTH	CB LUG TORQUE
H-FRAME THERMAL-MAGNETIC 15-150 AMP 80% RATED	AL150HD	(1) AL #14 - 3/0 AWG (1) CU #14 - 3/0 AWG	0.65 inch	#14 - #10 50 lb-in (6.0 Nm) #8 - 3/0 120 lb-in (14.0 Nm)
J-FRAME THERMAL-MAGNETIC 175 AMP 80% RATED	AL175HD	(1) AL #4 - 4/0 AWG (1) CU #4 - 4/0 AWG	1.00 inch	225 lb-in (26.0 Nm)
J-FRAME THERMAL-MAGNETIC 200-250 AMP 80% RATED	AL250JD	(1) AL 3/0 - 350 kcmil (1) CU 3/0 - 350 kcmil	1.00 inch	225 lb-in (26.0 Nm)
J-FRAME LSI ELECTRONIC TRIP ADJUSTABLE TRIP 70-250 AMP 100% RATED, COPPER CONDUCTORS ONLY	CU250JD	(1) CU 1/0 - 300 kcmil	1.00 inch	250 lb-in (28.0 Nm)
L-FRAME (400) LSI ELECTRONIC TRIP ADJUSTABLE TRIP 125-400 AMP 80% RATED	AL400L61K3	(1) AL #2 - 500 kcmil (1) CU #2 - 600 kcmil	1.20 inch	442 lb-in (50 Nm)
L-FRAME (400) LSI ELECTRONIC TRIP ADJUSTABLE TRIP 125-400 AMP 100% RATED, COPPER CONDUCTORS ONLY	AL600LS2K3	(2) CU 2/0 - 500 kcmil	(1) 1.20 inch (1) 2.40 inch	442 lb-in (50 Nm)
L-FRAME (600) LSI ELECTRONIC TRIP ADJUSTABLE TRIP 200-600 AMP 80% RATED 100% RATED, COPPER CONDUCTORS ONLY	AL600LS2K3	(2) AL 2/0 - 500 kcmil (2) CU 2/0 - 500 kcmil	(1) 1.20 inch (1) 2.40 inch	442 lb-in (50 Nm)
P-FRAME MANUAL & AUTOMATIC LSI ELECTRONIC TRIP ADJUSTABLE TRIP 400, 600 & 800 AMP 80% AND 100% RATED	AL800LS2K3	(3) AL 3/0 - 500 kcmil (3) CU 3/0 - 500 kcmil	(3) 1.20 inch	442 lb-in (50 Nm)

CIRCUIT BREAKER ACCESSORIES	
1	SHUNT TRIP (MX) P/N A043X760 12 VDC COIL BURDEN < 5 WATTS 10 AMP IN-RUSH
2	AUXILIARY CONTACTS P/N A043X785 OPEN/CLOSED (OF) TRIP INDICATION (SD) FORM C CONTACTS RATING: 6 AMPS AT 24 VAC, 48 VAC, 110 VAC 6 AMPS AT 24 VDC, 2.5 AMPS AT 48 VDC, 0.6 AMPS AT 110 VDC
3	H & J FRAME, MAXIMUM OF 4 CONTACTS PER CIRCUIT BREAKER L FRAME, MAXIMUM OF 5 CONTACTS PER CIRCUIT BREAKER P FRAME, MAXIMUM OF 5 CONTACTS PER CIRCUIT BREAKER
	ACCESSORY KIT P/N A060M822 FOR TOP ENTRY LOAD CABLE ENTRY APPLICABLE FOR MODEL AND BREAKER CONFIGURATION AS PER "TABLE 1"

TABLE 1				
KIT PART NUMBER	MODELS AFFECTED	ENCLOSURES AFFECTED		
A060M822	C125 N6-C150 N6 C125 D6D-C200 D6D	OPEN ONLY		
KIT PART NUMBER	NUMBER OF CB'S	LIMITATION		
		POS A	POS B	POS C
A060M822	1	ANY RATING	-	-
	2	ANY RATING	600A OR BELOW	-
	3	ANY RATING	400A OR BELOW	250A OR BELOW

UNLESS OTHERWISE SPECIFIED, ALL DIMENSIONS ARE IN MILLIMETERS	DO NOT SCALE PRINT	APP'D A. JOHNSON CER. A. JOHNSON APP'D P. LARSON DATE 02MAY16	CUMMINS POWER GENERATION OUTLINE, CIRCUIT BREAKER
ANG TOL SCALE 1/4	SCALE 1/2	DATE 02MAY16	PGF A055B603

REV NO	REV	NO	REVISION	REV	NO	DATE
ECO-181477	E	-	-	RT	WT	N. TOLADAN 05NOV18

"L" FRAME SHOWN (400 - 600 amp)

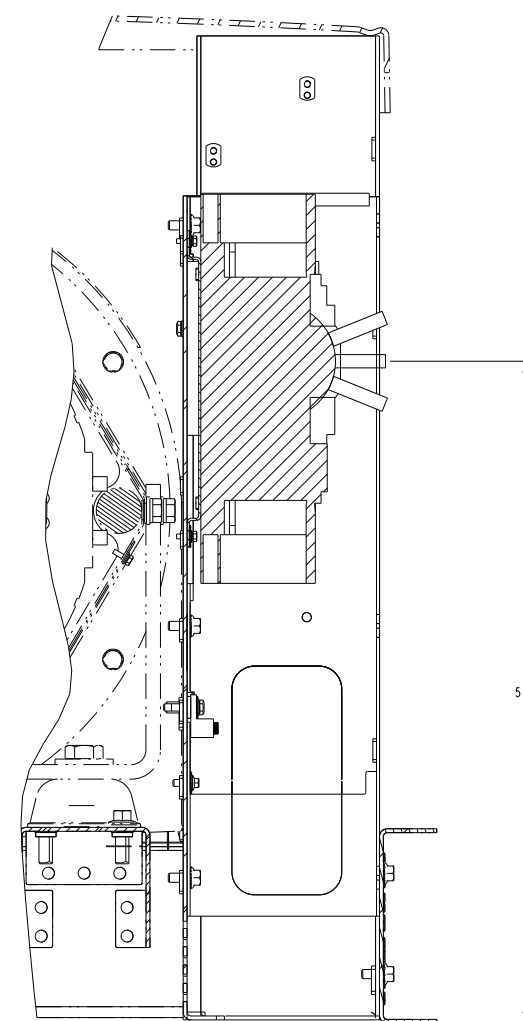
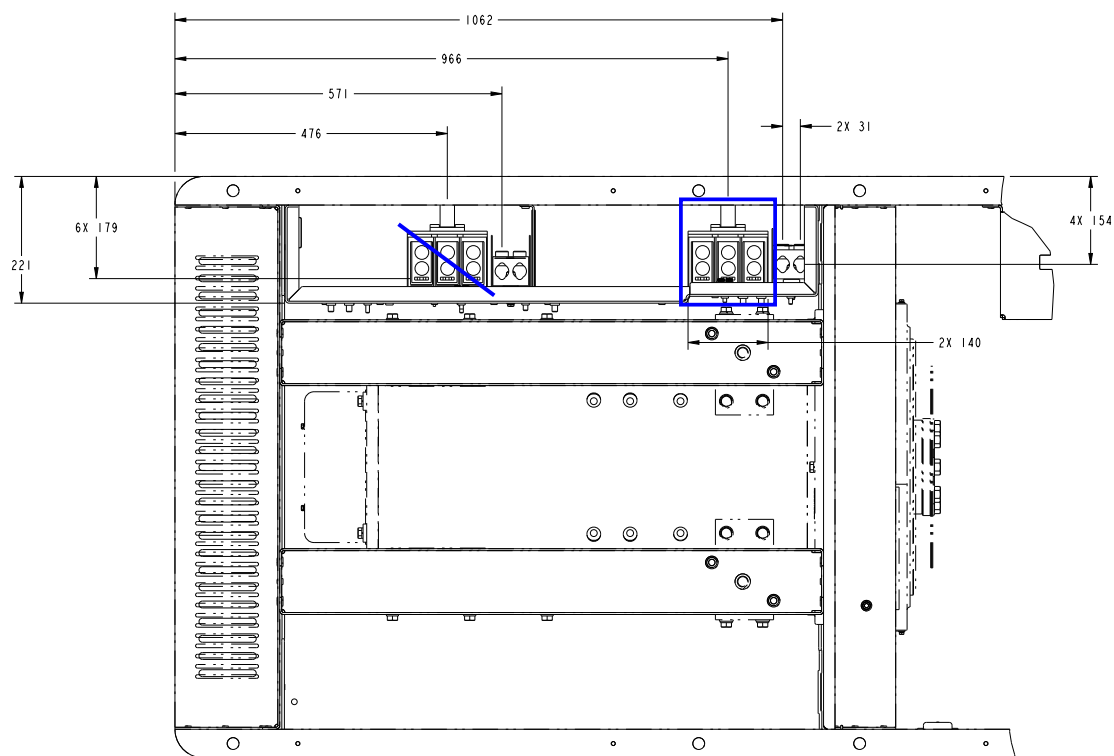
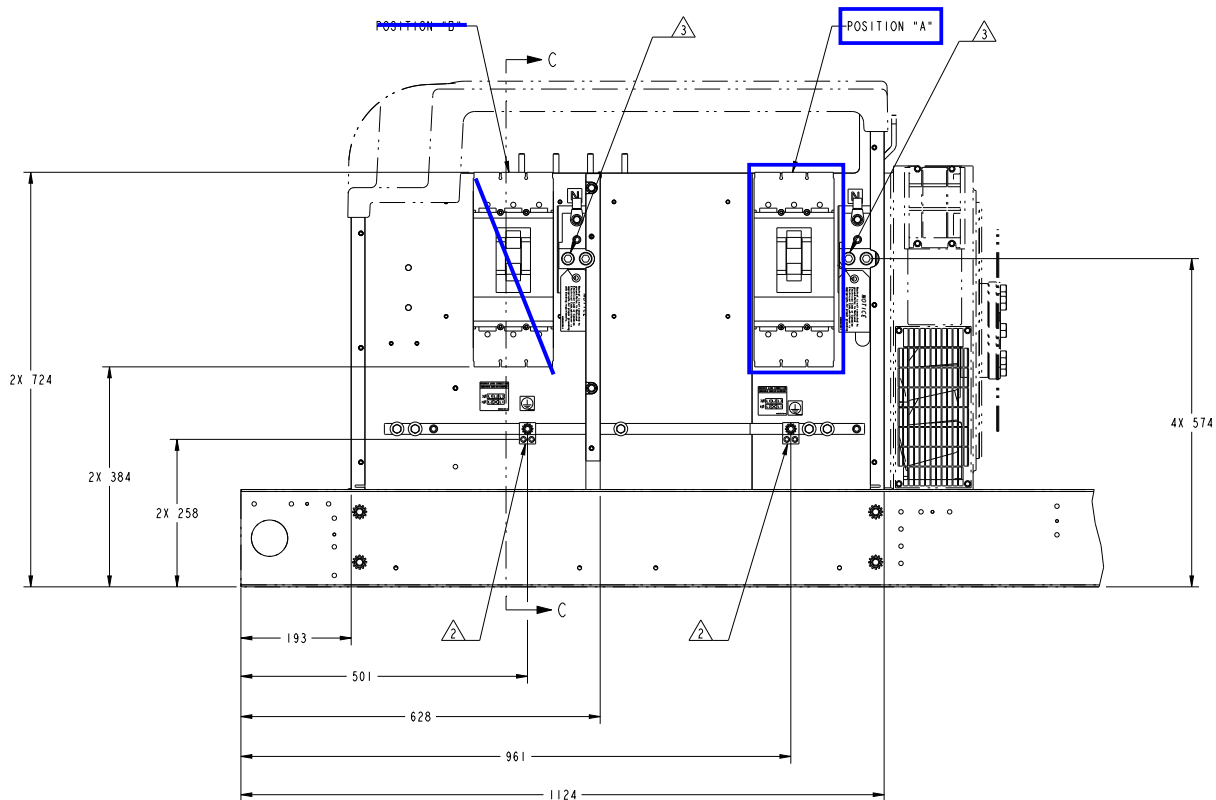

SECTION C-C
SCALE 1/2

UNLESS OTHERWISE SPECIFIED, ALL DIMENSIONS ARE IN MILLIMETERS		APP'D	CUMMINS POWER GENERATION	
± 1	0.00 - 4.99 +0.15/-0.00	A. JOHNSON	CUMMINS POWER GENERATION	OUTLINE, CIRCUIT BREAKER
± 0.8	5.00 - 9.99 +0.20/-0.10	A. JOHNSON		
± 0.5	10.00 - 17.49 +0.25/-0.13	P. LARSON	DATE	02MAY16
± 0.38	17.50 - 24.99 +0.30/-0.13		SITE CODE	
ANG TOL	SCALE	DATE	PGF	E
± 1.0°	1/4	02MAY16		A055B603

REV NO	REV	NO	REVISION	REV	NO	DATE
ECO-181477	E	-	-	RT	MT	OSNOV18

"H" FRAME SHOWN (15 - 150 amp)

"L" FRAME SHOWN (400 - 600 amp)

Not applicable on this system

Not applicable on this system

Not applicable on this system

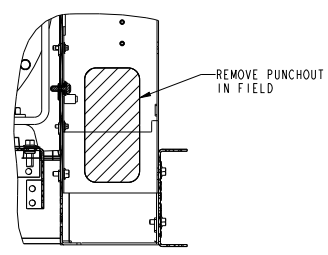
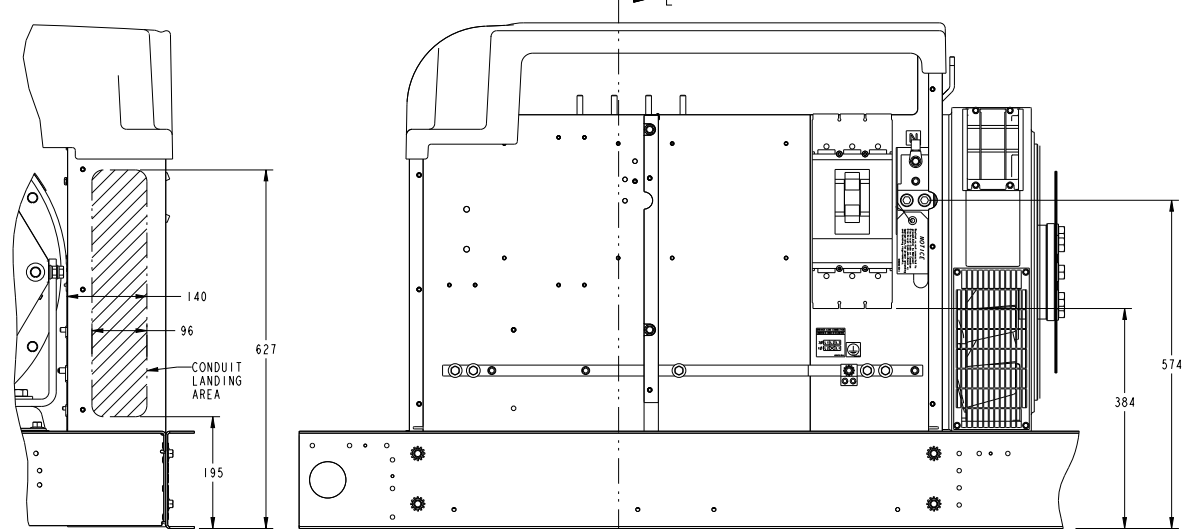
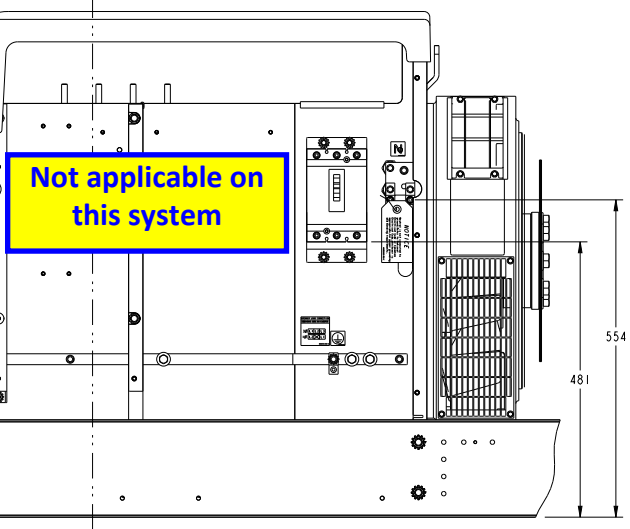

SECTION E-E

"J" FRAME SHOWN (175 - 250 amp)

"P" FRAME SHOWN (400-800 amp)

Not applicable on this system

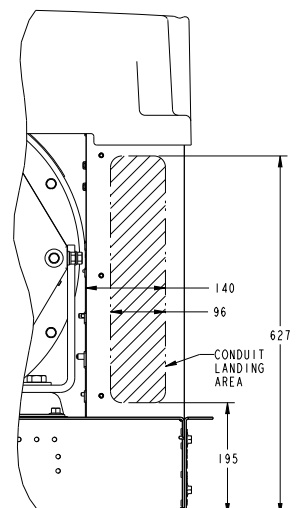
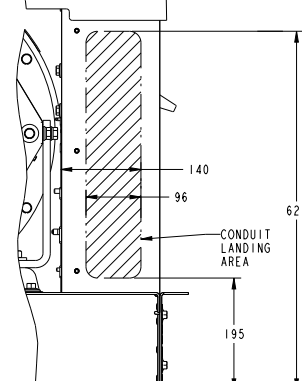
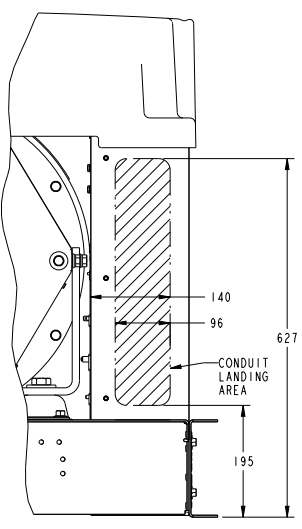
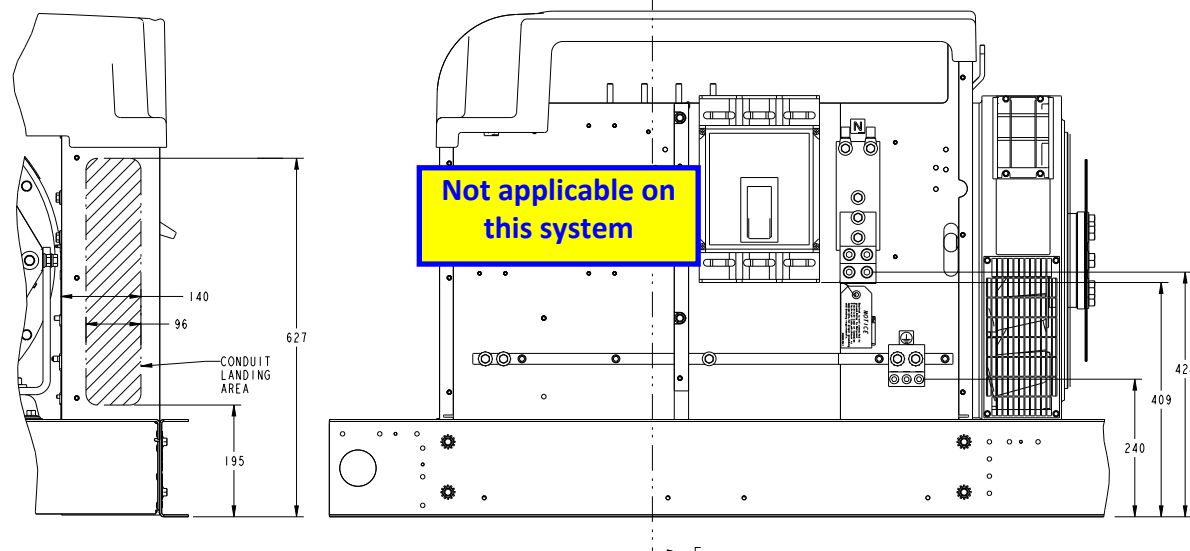
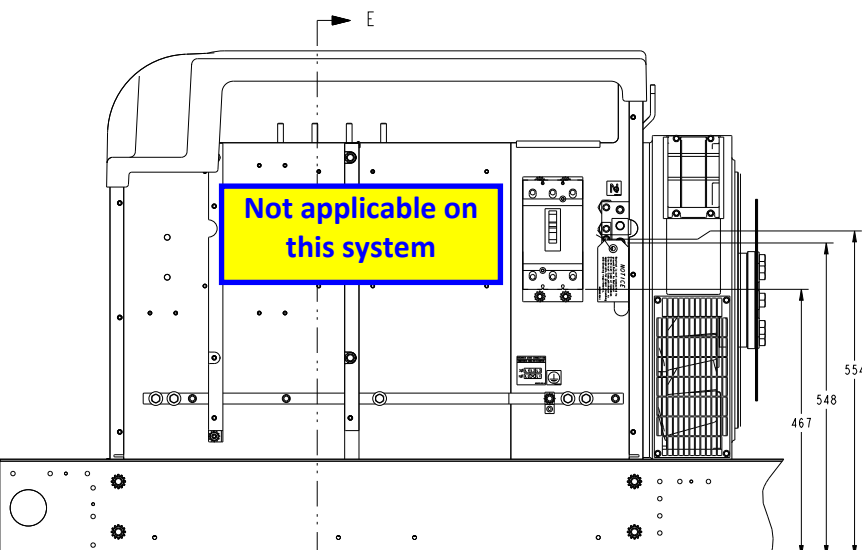

UNLESS OTHERWISE SPECIFIED, ALL DIMENSIONS ARE IN MILLIMETERS		DO NOT SCALE PRINT	APP'D A. JOHNSON	CUMMINS POWER GENERATION
± 0.1	0.00 - 4.99 ± 0.15 / 0.00		CAD A. JOHNSON	
± 0.2	5.00 - 9.99 ± 0.20 / 0.10		APP'D P. LARSON	OUTLINE, CIRCUIT BREAKER
± 0.38	10.00 - 17.49 ± 0.25 / 0.13		DATE 02MAY16	
± 1.0	17.50 - 24.99 ± 0.30 / 0.13		DATE 02MAY16	SITE CODE
ANG TOL	SCALE	DATE	DATE	PGF
± 1.0°	1/4	02MAY16	02MAY16	E

REL NO	REV	NO	REVISION	DWN	CKD	APVD	DATE
ECO-181040	B	1	VIEW FROM AIR OUTLET SIDE WAS AIR OUTLET VIEW	DAH	DAH	GILLETT	19OCT18
		2	ADD DISCHARGE DIMENSIONS TO TOP VIEW	DAH	DAH	GILLETT	19OCT18

NOTES:

- DIM [] IN INCHES
- WITH F231-2 ENCLOSURE INSTALLED THE GENERATOR SET WEIGHT INCREASES BY 179 KG (395 LBS).
WITH F217-2 ENCLOSURE INSTALLED THE GENERATOR SET WEIGHT INCREASES BY 195 KG (429 LBS).
- WITH F231-2 INSTALLED THE CENTER OF GRAVITY OF THE GENERATOR SET SHIFTS APPROXIMATELY 42 MM (1.7 INCH) TOWARDS THE AIR DISCHARGE END AND 61MM (2.4 INCH) HIGHER.
WITH F217-2 INSTALLED THE CENTER OF GRAVITY OF THE GENERATOR SET SHIFTS APPROXIMATELY 57 MM (2.2 INCH) TOWARDS THE AIR DISCHARGE END AND 61MM (2.4 INCH) HIGHER.
CHANGES IN CENTER OF GRAVITY LISTED ARE FOR GENERATOR SETS WITHOUT SUBBASE FUEL TANKS.
REFER TO OPEN GENERATOR SET OUTLINE DRAWING FOR CG LOCATIONS PRIOR TO ENCLOSURE INSTALLATION.

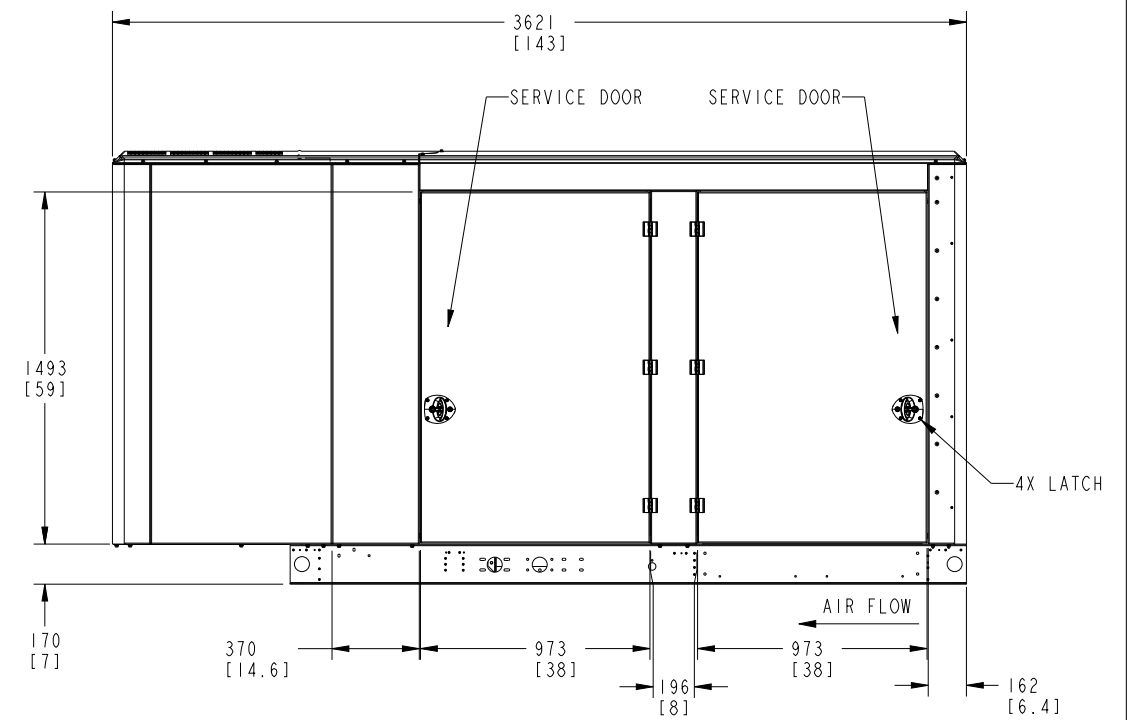
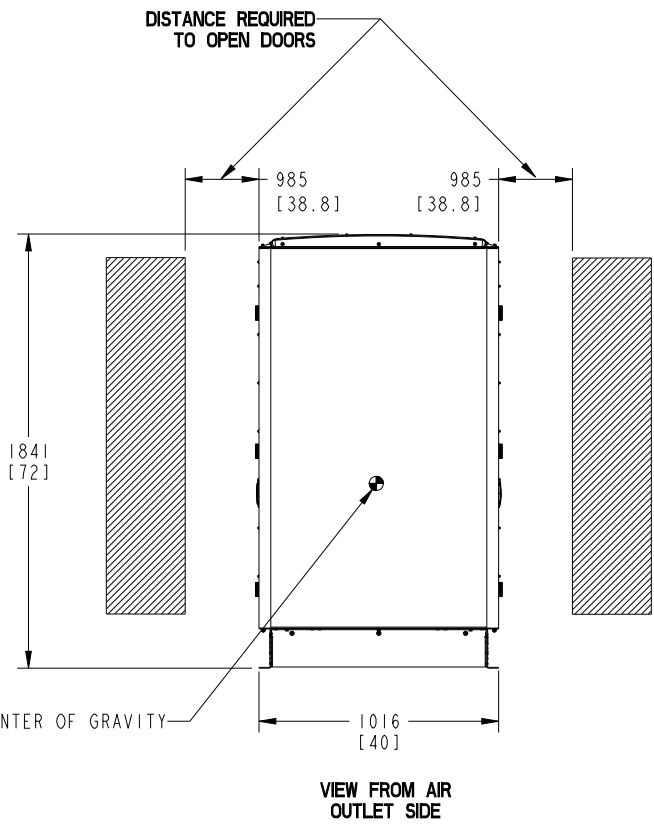
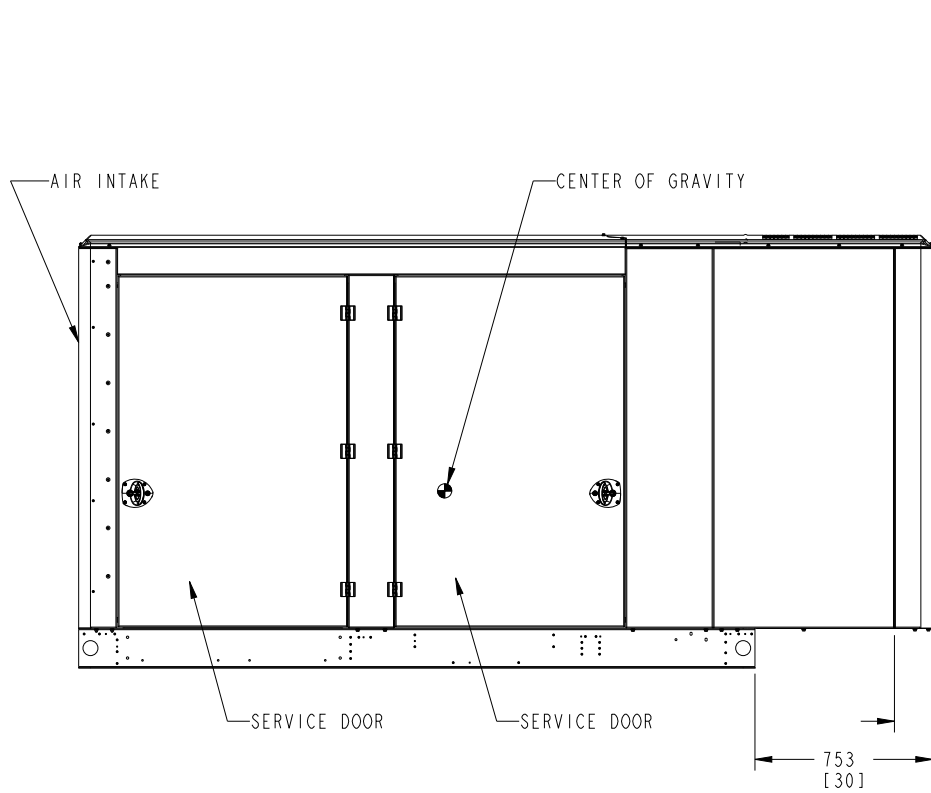
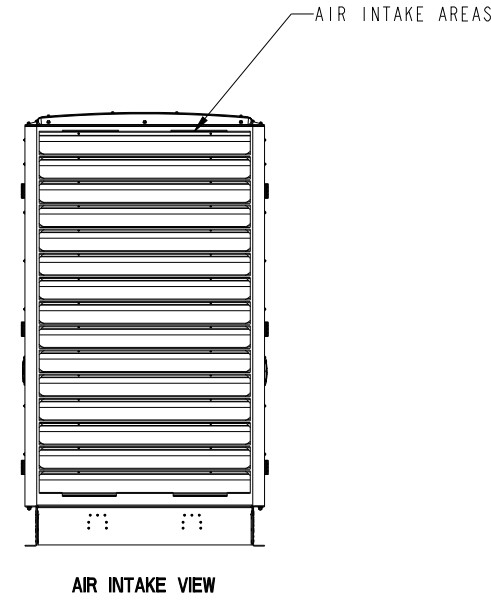
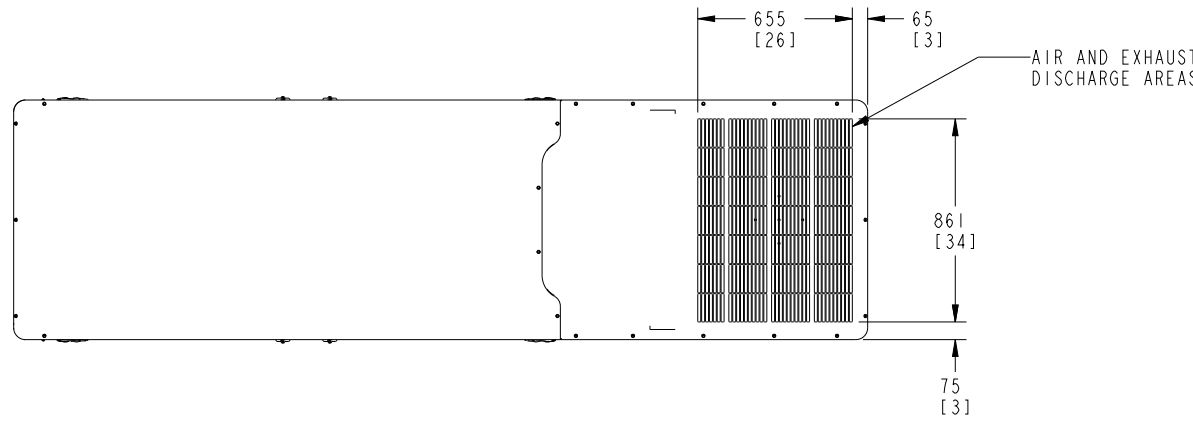

F231-2 ENCLOSURE CONFIGURATION

C125D6D, C150D6D, C175D6D, C200D6D

UNLESS OTHERWISE SPECIFIED, ALL DIMENSIONS ARE IN MILLIMETERS		SHW TO: A055V240	DWN: D HOFMEISTER		CUMMINS POWER GENERATION
DO NOT SCALE PRINT		CKD: D HOFMEISTER	APVD: D GILLETT		OUTLINE, ENCLOSURE
DATE: 29MAR18		FIRST USED ON: ARROW		SITE CODE: PGF	CAD SHEET: 1 OF 2
PART NO: A060C609		REV: D		DATE: 19OCT18	

REL NO	REV	NO	REVISION	DWN	CKD	APVD	DATE
ECO-181040	B	-	-----	DAH	DAH	GILLETT	19OCT18

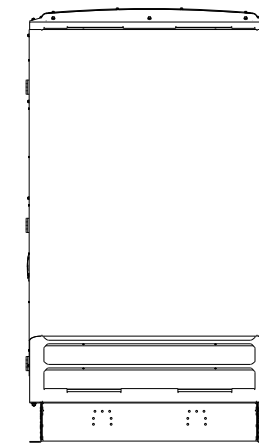
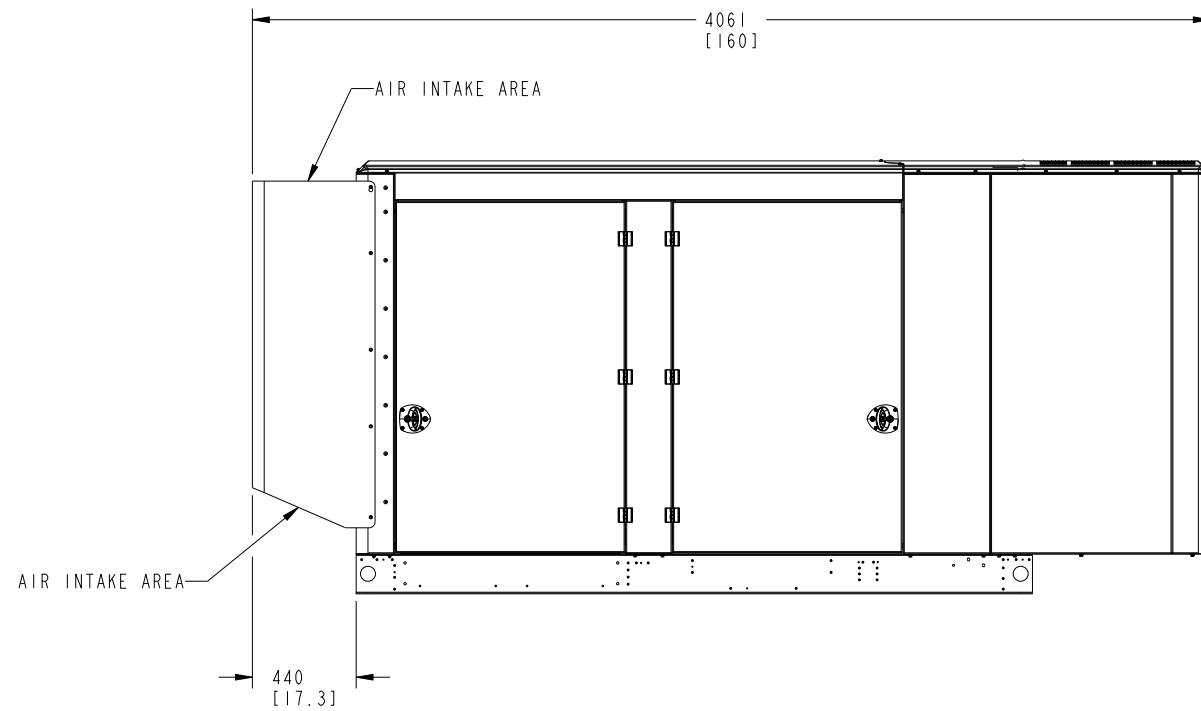
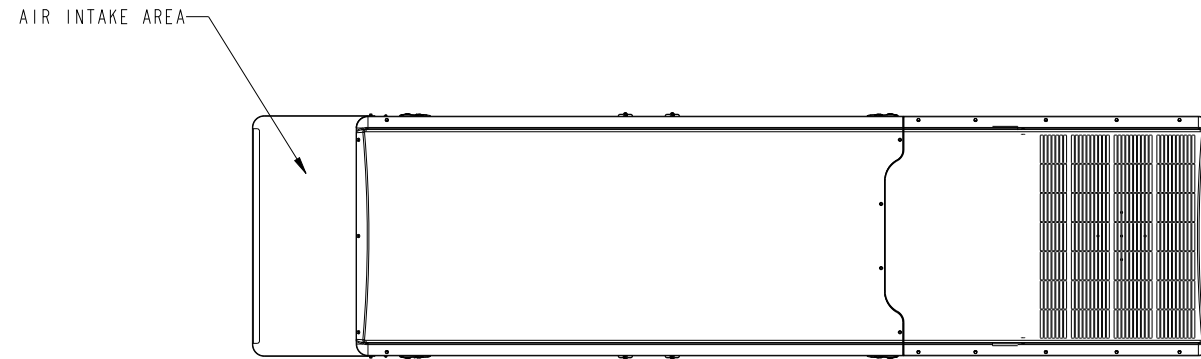

F217-2 ENCLOSURE CONFIGURATION
REFER TO PAGE 1 (F231-2 ENCLOSURE) FOR
OTHER F217-2 ENCLOSURE DIMENSIONS

UNLESS OTHERWISE SPECIFIED, ALL DIMENSIONS ARE IN MILLIMETERS		SHW TO A055V240	DWN D HOFMEISTER		CUMMINS POWER GENERATION	
DO NOT SCALE PRINT		CKD D HOFMEISTER	APVD D GILLETT		OUTLINE, ENCLOSURE	
DIM	TOL	DATE 29MAR18	SITE CODE			
X ± 1	0.00- 4.99 +0.15/-0.08	FOR INTERPRETATION OF DIMENSIONING AND TOLERANCING, SEE ASME Y14.5-2009	PGF	D	A060C609	CAD SHEET 2 of 2
.X ± 0.8	5.00- 9.99 +0.20/-0.10					
.XX ± 0.38	10.00-17.49 +0.25/-0.13					
	17.50-24.99 +0.30/-0.13					
ANG TOL ± 1.0°	SCALE 1/15	THIS DOCUMENT (AND THE INFORMATION SHOWN THEREON) IS CONFIDENTIAL AND PROPRIETARY AND SHALL NOT BE DISCLOSED TO OTHERS IN HARD COPY OR ELECTRONIC FORM, REPRODUCED BY ANY MEANS, OR USED FOR ANY PURPOSE WITHOUT WRITTEN CONSENT OF CUMMINS INC.	ARROW			

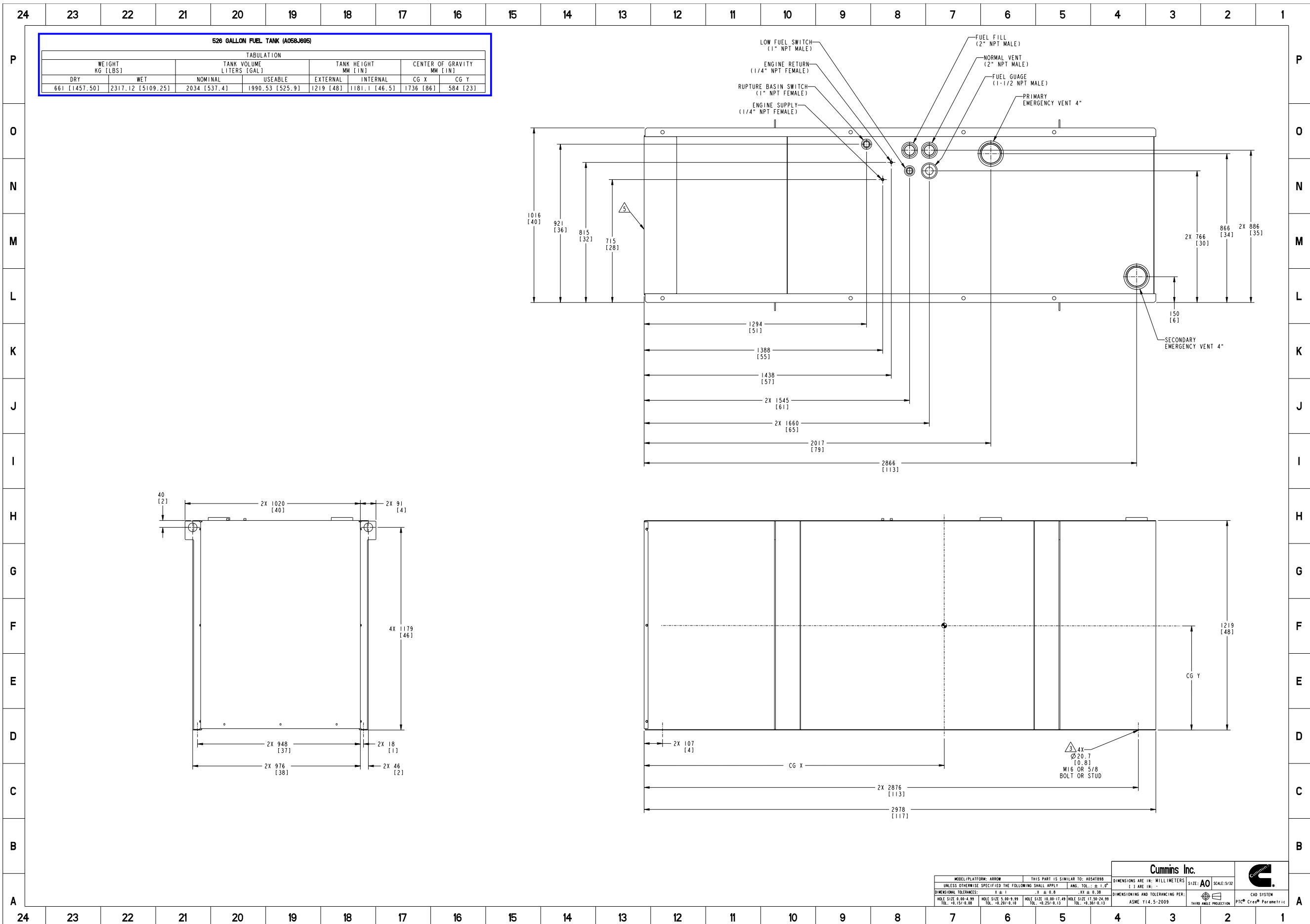

Document Generated: 01APR2022 11:17 GMT

MODEL/PLATFORM: ARROW	THIS PART IS SIMILAR TO: A054T088	DIMENSIONS ARE IN: MILLIMETERS	SIZE: A0 (SCALE: 5/32)					
UNLESS OTHERWISE SPECIFIED THE FOLLOWING SHALL APPLY	ANG. TOL.: ± 1.0°	() ARE IN: -						
DIMENSIONAL TOLERANCES:	X ± 0.8	XX ± 0.38	DIMENSIONING AND TOLERANCING PER: ASME Y14.5-2009					
HOLE SIZE: 0.00-4.99	TOL. +0.13/-0.08	HOLE SIZE: 5.00-9.99	TOL. +0.20/-0.10	HOLE SIZE: 10.00-12.49	TOL. +0.25/-0.13	HOLE SIZE: 12.50-24.99	TOL. +0.30/-0.13	CAD SYSTEM: PTC® Creo® Parametric

	24	23	22	21	20	19	18	17	16	15	14	13	12	11	10	9	8	7	6	5	4	3	2	1																																																																																																																																																																																																																																																																																																																																																																																																																																																																																																																																																																																																																																																																																																																																																																																																																																																								
P O N M L K J I H G F E D C B A	<p>A058J692 TANK DEPTH CHART</p> <table border="1"><thead><tr><th>HEIGHT (IN)</th><th>HEIGHT (MM)</th><th>USABLE VOLUME (GAL)</th><th>TOTAL VOLUME (GAL)</th></tr></thead><tbody><tr><td>0.5</td><td>12.7</td><td>0</td><td>5.8</td></tr><tr><td>1.0</td><td>25.4</td><td>2.9</td><td>11.6</td></tr><tr><td>1.5</td><td>38.1</td><td>8.7</td><td>17.4</td></tr><tr><td>2.0</td><td>50.8</td><td>14.4</td><td>23.1</td></tr><tr><td>2.5</td><td>63.5</td><td>20.2</td><td>28.9</td></tr><tr><td>3.0</td><td>76.2</td><td>26.0</td><td>34.7</td></tr><tr><td>3.5</td><td>88.9</td><td>31.8</td><td>40.4</td></tr><tr><td>4.0</td><td>101.6</td><td>37.5</td><td>46.2</td></tr><tr><td>4.5</td><td>114.3</td><td>43.3</td><td>52.0</td></tr><tr><td>5.0</td><td>127.0</td><td>49.1</td><td>57.8</td></tr><tr><td>5.5</td><td>139.7</td><td>54.9</td><td>63.6</td></tr><tr><td>6.0</td><td>152.4</td><td>60.6</td><td>69.3</td></tr><tr><td>6.5</td><td>165.1</td><td>66.4</td><td>75.1</td></tr><tr><td>7.0</td><td>177.8</td><td>72.2</td><td>80.9</td></tr><tr><td>7.5</td><td>190.5</td><td>78.0</td><td>86.6</td></tr><tr><td>8.0</td><td>203.2</td><td>83.7</td><td>92.4</td></tr><tr><td>8.5</td><td>215.9</td><td>89.5</td><td>98.2</td></tr><tr><td>9.0</td><td>228.6</td><td>95.3</td><td>104.0</td></tr><tr><td>9.5</td><td>241.3</td><td>101.1</td><td>109.8</td></tr><tr><td>10.0</td><td>254.0</td><td>106.8</td><td>115.6</td></tr><tr><td>10.5</td><td>266.7</td><td>112.6</td><td>121.3</td></tr><tr><td>11.0</td><td>279.4</td><td>118.4</td><td>127.1</td></tr><tr><td>11.5</td><td>292.1</td><td>124.2</td><td>132.9</td></tr><tr><td>12.0</td><td>304.8</td><td>129.9</td><td>138.7</td></tr><tr><td>12.5</td><td>317.5</td><td>135.7</td><td>144.5</td></tr><tr><td>13.0</td><td>330.2</td><td>141.5</td><td>150.2</td></tr><tr><td>13.5</td><td>342.9</td><td>147.3</td><td>155.9</td></tr><tr><td>14.0</td><td>355.6</td><td>153.0</td><td>161.7</td></tr><tr><td>14.5</td><td>368.3</td><td>158.8</td><td>167.5</td></tr><tr><td>15.0</td><td>381.0</td><td>164.6</td><td>173.3</td></tr><tr><td>15.5</td><td>393.7</td><td>170.4</td><td>179.0</td></tr><tr><td>16.0</td><td>406.4</td><td>176.1</td><td>184.8</td></tr><tr><td>16.5</td><td>419.1</td><td>181.9</td><td>190.6</td></tr><tr><td>17.0</td><td>431.8</td><td>187.7</td><td>196.4</td></tr><tr><td>17.5</td><td>444.5</td><td>193.5</td><td>202.1</td></tr><tr><td>18.0</td><td>457.2</td><td>199.2</td><td>207.9</td></tr><tr><td>18.5</td><td>469.9</td><td>205.0</td><td>213.7</td></tr><tr><td>19.0</td><td>482.6</td><td>210.8</td><td>219.5</td></tr><tr><td>19.5</td><td>495.3</td><td>216.6</td><td>225.2</td></tr><tr><td>20.0</td><td>508.0</td><td>222.3</td><td>231.0</td></tr><tr><td>20.5</td><td>520.7</td><td>228.1</td><td>236.8</td></tr><tr><td>21.0</td><td>533.4</td><td>233.9</td><td>242.6</td></tr><tr><td>21.5</td><td>546.1</td><td>239.7</td><td>248.3</td></tr><tr><td>22.0</td><td>558.8</td><td>245.4</td><td>254.1</td></tr><tr><td>22.5</td><td>571.5</td><td>251.2</td><td>259.9</td></tr><tr><td>23.0</td><td>584.2</td><td>254.1</td><td>265.7</td></tr><tr><td>23.5</td><td>596.9</td><td>259.9</td><td>271.4</td></tr></tbody></table> <p>A058J694 TANK DEPTH CHART</p> <table border="1"><thead><tr><th>HEIGHT (IN)</th><th>HEIGHT (MM)</th><th>USABLE VOLUME (GAL)</th><th>TOTAL VOLUME (GAL)</th></tr></thead><tbody><tr><td>0.5</td><td>12.7</td><td>0</td><td>5.8</td></tr><tr><td>1.0</td><td>25.4</td><td>2.9</td><td>11.6</td></tr><tr><td>1.5</td><td>38.1</td><td>8.7</td><td>17.4</td></tr><tr><td>2.0</td><td>50.8</td><td>14.5</td><td>23.1</td></tr><tr><td>2.5</td><td>63.5</td><td>20.2</td><td>28.9</td></tr><tr><td>3.0</td><td>76.2</td><td>26.0</td><td>34.7</td></tr><tr><td>3.5</td><td>88.9</td><td>31.8</td><td>40.5</td></tr><tr><td>4.0</td><td>101.6</td><td>37.6</td><td>46.3</td></tr><tr><td>4.5</td><td>114.3</td><td>43.4</td><td>52.1</td></tr><tr><td>5.0</td><td>127.0</td><td>49.2</td><td>57.8</td></tr><tr><td>5.5</td><td>139.7</td><td>55.0</td><td>63.6</td></tr><tr><td>6.0</td><td>152.4</td><td>60.7</td><td>69.4</td></tr><tr><td>6.5</td><td>165.1</td><td>66.5</td><td>75.2</td></tr><tr><td>7.0</td><td>177.8</td><td>72.3</td><td>81.0</td></tr><tr><td>7.5</td><td>190.5</td><td>78.1</td><td>86.8</td></tr><tr><td>8.0</td><td>203.2</td><td>83.9</td><td>92.6</td></tr><tr><td>8.5</td><td>215.9</td><td>89.7</td><td>98.3</td></tr><tr><td>9.0</td><td>228.6</td><td>95.4</td><td>104.1</td></tr><tr><td>9.5</td><td>241.3</td><td>101.2</td><td>109.9</td></tr><tr><td>10.0</td><td>254.0</td><td>107.0</td><td>115.7</td></tr><tr><td>10.5</td><td>266.7</td><td>112.8</td><td>121.5</td></tr><tr><td>11.0</td><td>279.4</td><td>118.6</td><td>127.3</td></tr><tr><td>11.5</td><td>292.1</td><td>124.4</td><td>133.0</td></tr><tr><td>12.0</td><td>304.8</td><td>130.2</td><td>138.8</td></tr><tr><td>12.5</td><td>317.5</td><td>135.9</td><td>144.6</td></tr><tr><td>13.0</td><td>330.2</td><td>141.7</td><td>150.4</td></tr><tr><td>13.5</td><td>342.9</td><td>147.5</td><td>156.2</td></tr><tr><td>14.0</td><td>355.6</td><td>153.3</td><td>162.0</td></tr><tr><td>14.5</td><td>368.3</td><td>159.1</td><td>167.8</td></tr><tr><td>15.0</td><td>381.0</td><td>164.9</td><td>173.5</td></tr><tr><td>15.5</td><td>393.7</td><td>170.6</td><td>179.3</td></tr><tr><td>16.0</td><td>406.4</td><td>176.4</td><td>185.1</td></tr><tr><td>16.5</td><td>419.1</td><td>182.2</td><td>190.9</td></tr><tr><td>17.0</td><td>431.8</td><td>188.0</td><td>196.7</td></tr><tr><td>17.5</td><td>444.5</td><td>193.8</td><td>202.5</td></tr><tr><td>18.0</td><td>457.2</td><td>199.6</td><td>208.2</td></tr><tr><td>18.5</td><td>469.9</td><td>205.4</td><td>214.0</td></tr><tr><td>19.0</td><td>482.6</td><td>211.1</td><td>219.8</td></tr><tr><td>19.5</td><td>495.3</td><td>216.9</td><td>225.6</td></tr><tr><td>20.0</td><td>508.0</td><td>222.7</td><td>231.4</td></tr><tr><td>20.5</td><td>520.7</td><td>228.5</td><td>237.2</td></tr><tr><td>21.0</td><td>533.4</td><td>234.3</td><td>243.0</td></tr><tr><td>21.5</td><td>546.1</td><td>240.1</td><td>248.7</td></tr><tr><td>22.0</td><td>558.8</td><td>245.8</td><td>254.5</td></tr><tr><td>22.5</td><td>571.5</td><td>251.6</td><td>260.3</td></tr><tr><td>23.0</td><td>584.2</td><td>254.5</td><td>266.1</td></tr><tr><td>23.5</td><td>596.9</td><td>260.3</td><td>271.9</td></tr><tr><td>24.0</td><td>609.6</td><td>266.1</td><td>277.7</td></tr><tr><td>24.5</td><td>622.3</td><td>271.9</td><td>283.4</td></tr><tr><td>25.0</td><td>635.0</td><td>277.7</td><td>289.2</td></tr><tr><td>25.5</td><td>647.7</td><td>283.4</td><td>295.0</td></tr><tr><td>26.0</td><td>660.4</td><td>289.2</td><td>300.8</td></tr><tr><td>26.5</td><td>673.1</td><td>295.0</td><td>306.6</td></tr><tr><td>27.0</td><td>685.8</td><td>300.8</td><td>312.4</td></tr><tr><td>27.5</td><td>698.5</td><td>306.6</td><td>318.2</td></tr><tr><td>28.0</td><td>711.2</td><td>312.4</td><td>323.9</td></tr><tr><td>28.5</td><td>723.9</td><td>318.2</td><td>329.7</td></tr><tr><td>29.0</td><td>736.6</td><td>323.9</td><td>335.5</td></tr><tr><td>29.5</td><td>749.3</td><td>329.7</td><td>341.3</td></tr><tr><td>30.0</td><td>762.0</td><td>335.5</td><td>347.1</td></tr><tr><td>30.5</td><td>774.7</td><td>341.3</td><td>352.9</td></tr><tr><td>31.0</td><td>787.4</td><td>347.1</td><td>358.6</td></tr><tr><td>31.5</td><td>800.1</td><td>352.9</td><td>364.4</td></tr></tbody></table> <p>A058J695 TANK DEPTH CHART</p> <table border="1"><thead><tr><th>HEIGHT (IN)</th><th>HEIGHT (MM)</th><th>USABLE VOLUME (GAL)</th><th>TOTAL VOLUME (GAL)</th></tr></thead><tbody><tr><td>0.5</td><td>12.7</td><td>0</td><td>5.8</td></tr><tr><td>1.0</td><td>25.4</td><td>2.9</td><td>11.6</td></tr><tr><td>1.5</td><td>38.1</td><td>8.7</td><td>17.3</td></tr><tr><td>2.0</td><td>50.8</td><td>14.4</td><td>23.1</td></tr><tr><td>2.5</td><td>63.5</td><td>20.2</td><td>28.9</td></tr><tr><td>3.0</td><td>76.2</td><td>26.0</td><td>34.7</td></tr><tr><td>3.5</td><td>88.9</td><td>31.8</td><td>40.5</td></tr><tr><td>4.0</td><td>101.6</td><td>37.6</td><td>46.2</td></tr><tr><td>4.5</td><td>114.3</td><td>43.3</td><td>52.0</td></tr><tr><td>5.0</td><td>127.0</td><td>49.1</td><td>57.8</td></tr><tr><td>5.5</td><td>139.7</td><td>54.9</td><td>63.6</td></tr><tr><td>6.0</td><td>152.4</td><td>60.7</td><td>69.3</td></tr><tr><td>6.5</td><td>165.1</td><td>66.5</td><td>75.1</td></tr><tr><td>7.0</td><td>177.8</td><td>72.2</td><td>80.9</td></tr><tr><td>7.5</td><td>190.5</td><td>78.0</td><td>86.7</td></tr><tr><td>8.0</td><td>203.2</td><td>83.8</td><td>92.5</td></tr><tr><td>8.5</td><td>215.9</td><td>89.6</td><td>98.2</td></tr><tr><td>9.0</td><td>228.6</td><td>95.3</td><td>104.0</td></tr><tr><td>9.5</td><td>241.3</td><td>101.1</td><td>109.8</td></tr><tr><td>10.0</td><td>254.0</td><td>106.9</td><td>115.6</td></tr><tr><td>10.5</td><td>266.7</td><td>112.7</td><td>121.4</td></tr><tr><td>11.0</td><td>279.4</td><td>118.5</td><td>127.1</td></tr><tr><td>11.5</td><td>292.1</td><td>124.2</td><td>132.9</td></tr><tr><td>12.0</td><td>304.8</td><td>130.0</td><td>138.7</td></tr><tr><td>12.5</td><td>317.5</td><td>135.8</td><td>144.5</td></tr><tr><td>13.0</td><td>330.2</td><td>141.6</td><td>150.2</td></tr><tr><td>13.5</td><td>342.9</td><td>147.4</td><td>156.0</td></tr><tr><td>14.0</td><td>355.6</td><td>153.1</td><td>161.8</td></tr><tr><td>14.5</td><td>368.3</td><td>158.9</td><td>167.6</td></tr><tr><td>15.0</td><td>381.0</td><td>164.7</td><td>173.4</td></tr><tr><td>15.5</td><td>393.7</td><td>170.5</td><td>179.1</td></tr><tr><td>16.0</td><td>406.4</td><td>176.3</td><td>184.9</td></tr><tr><td>16.5</td><td>419.1</td><td>182.0</td><td>190.7</td></tr><tr><td>17.0</td><td>431.8</td><td>187.8</td><td>196.5</td></tr><tr><td>17.5</td><td>444.5</td><td>193.6</td><td>202.3</td></tr><tr><td>18.0</td><td>457.2</td><td>199.4</td><td>208.0</td></tr><tr><td>18.5</td><td>469.9</td><td>205.1</td><td>213.8</td></tr><tr><td>19.0</td><td>482.6</td><td>210.9</td><td>219.6</td></tr><tr><td>19.5</td><td>495.3</td><td>216.7</td><td>225.4</td></tr><tr><td>20.0</td><td>508.0</td><td>222.5</td><td>231.2</td></tr><tr><td>20.5</td><td>520.7</td><td>228.3</td><td>236.9</td></tr><tr><td>21.0</td><td>533.4</td><td>234.0</td><td>242.7</td></tr><tr><td>21.5</td><td>546.1</td><td>239.8</td><td>248.5</td></tr><tr><td>22.0</td><td>558.8</td><td>245.6</td><td>254.3</td></tr><tr><td>22.5</td><td>571.5</td><td>251.4</td><td>260.0</td></tr><tr><td>23.0</td><td>584.2</td><td>254.3</td><td>265.8</td></tr><tr><td>23.5</td><td>596.9</td><td>260.0</td><td>271.6</td></tr><tr><td>24.0</td><td>609.6</td><td>265.8</td><td>277.4</td></tr><tr><td>24.5</td><td>622.3</td><td>271.6</td><td>283.2</td></tr><tr><td>25.0</td><td>635.0</td><td>277.4</td><td>289.0</td></tr><tr><td>25.5</td><td>647.7</td><td>283.2</td><td>294.7</td></tr><tr><td>26.0</td><td>660.4</td><td>288.9</td><td>300.5</td></tr><tr><td>26.5</td><td>673.1</td><td>294.7</td><td>306.3</td></tr><tr><td>27.0</td><td>685.8</td><td>300.5</td><td>312.1</td></tr><tr><td>27.5</td><td>698.5</td><td>306.3</td><td>317.8</td></tr><tr><td>28.0</td><td>711.2</td><td>312.1</td><td>323.6</td></tr><tr><td>28.5</td><td>723.9</td><td>317.8</td><td>329.4</td></tr><tr><td>29.0</td><td>736.6</td><td>323.6</td><td>335.2</td></tr><tr><td>29.5</td><td>749.3</td><td>329.4</td><td>340.9</td></tr><tr><td>30.0</td><td>762.0</td><td>335.2</td><td>346.7</td></tr><tr><td>30.5</td><td>774.7</td><td>340.9</td><td>352.5</td></tr><tr><td>31.0</td><td>787.4</td><td>346.7</td><td>358.3</td></tr><tr><td>31.5</td><td>800.1</td><td>352.5</td><td>364.1</td></tr><tr><td>32.0</td><td>812.8</td><td>358.3</td><td>369.8</td></tr><tr><td>32.5</td><td>825.5</td><td>364.1</td><td>375.6</td></tr><tr><td>33.0</td><td>838.2</td><td>369.8</td><td>381.4</td></tr><tr><td>33.5</td><td>850.9</td><td>375.6</td><td>387.2</td></tr><tr><td>34.0</td><td>863.6</td><td>381.4</td><td>393.0</td></tr><tr><td>34.5</td><td>876.3</td><td>387.2</td><td>398.7</td></tr><tr><td>35.0</td><td>889.0</td><td>393.0</td><td>404.5</td></tr><tr><td>35.5</td><td>901.7</td><td>398.7</td><td>410.3</td></tr><tr><td>36.0</td><td>914.4</td><td>404.5</td><td>416.1</td></tr><tr><td>36.5</td><td>927.1</td><td>410.3</td><td>421.9</td></tr><tr><td>37.0</td><td>939.8</td><td>416.1</td><td>427.6</td></tr><tr><td>37.5</td><td>952.5</td><td>421.9</td><td>433.4</td></tr><tr><td>38.0</td><td>965.2</td><td>427.6</td><td>439.2</td></tr><tr><td>38.5</td><td>977.9</td><td>433.4</td><td>445.0</td></tr><tr><td>39.0</td><td>990.6</td><td>439.2</td><td>450.7</td></tr><tr><td>39.5</td><td>1003.3</td><td>445.0</td><td>456.5</td></tr><tr><td>40.0</td><td>1016.0</td><td>450.7</td><td>462.3</td></tr><tr><td>40.5</td><td>1028.7</td><td>456.5</td><td>468.1</td></tr><tr><td>41.0</td><td>1041.4</td><td>462.3</td><td>473.9</td></tr><tr><td>41.5</td><td>1054.1</td><td>468.1</td><td>479.6</td></tr><tr><td>42.0</td><td>1066.8</td><td>473.9</td><td>485.4</td></tr><tr><td>42.5</td><td>1079.5</td><td>479.6</td><td>491.2</td></tr><tr><td>43.0</td><td>1092.2</td><td>485.4</td><td>497.0</td></tr><tr><td>43.5</td><td>1104.9</td><td>491.2</td><td>502.8</td></tr><tr><td>44.0</td><td>1117.6</td><td>497.0</td><td>508.5</td></tr><tr><td>44.5</td><td>1130.3</td><td>502.8</td><td>514.3</td></tr><tr><td>45.0</td><td>1143.0</td><td>508.5</td><td>520.1</td></tr><tr><td>45.5</td><td>1155.7</td><td>514.3</td><td>525.9</td></tr><tr><td>46.0</td><td>1168.4</td><td>520.1</td><td>531.6</td></tr><tr><td>46.5</td><td>1181.1</td><td>525.9</td><td>537.4</td></tr></tbody></table>																							HEIGHT (IN)	HEIGHT (MM)	USABLE VOLUME (GAL)	TOTAL VOLUME (GAL)	0.5	12.7	0	5.8	1.0	25.4	2.9	11.6	1.5	38.1	8.7	17.4	2.0	50.8	14.4	23.1	2.5	63.5	20.2	28.9	3.0	76.2	26.0	34.7	3.5	88.9	31.8	40.4	4.0	101.6	37.5	46.2	4.5	114.3	43.3	52.0	5.0	127.0	49.1	57.8	5.5	139.7	54.9	63.6	6.0	152.4	60.6	69.3	6.5	165.1	66.4	75.1	7.0	177.8	72.2	80.9	7.5	190.5	78.0	86.6	8.0	203.2	83.7	92.4	8.5	215.9	89.5	98.2	9.0	228.6	95.3	104.0	9.5	241.3	101.1	109.8	10.0	254.0	106.8	115.6	10.5	266.7	112.6	121.3	11.0	279.4	118.4	127.1	11.5	292.1	124.2	132.9	12.0	304.8	129.9	138.7	12.5	317.5	135.7	144.5	13.0	330.2	141.5	150.2	13.5	342.9	147.3	155.9	14.0	355.6	153.0	161.7	14.5	368.3	158.8	167.5	15.0	381.0	164.6	173.3	15.5	393.7	170.4	179.0	16.0	406.4	176.1	184.8	16.5	419.1	181.9	190.6	17.0	431.8	187.7	196.4	17.5	444.5	193.5	202.1	18.0	457.2	199.2	207.9	18.5	469.9	205.0	213.7	19.0	482.6	210.8	219.5	19.5	495.3	216.6	225.2	20.0	508.0	222.3	231.0	20.5	520.7	228.1	236.8	21.0	533.4	233.9	242.6	21.5	546.1	239.7	248.3	22.0	558.8	245.4	254.1	22.5	571.5	251.2	259.9	23.0	584.2	254.1	265.7	23.5	596.9	259.9	271.4	HEIGHT (IN)	HEIGHT (MM)	USABLE VOLUME (GAL)	TOTAL VOLUME (GAL)	0.5	12.7	0	5.8	1.0	25.4	2.9	11.6	1.5	38.1	8.7	17.4	2.0	50.8	14.5	23.1	2.5	63.5	20.2	28.9	3.0	76.2	26.0	34.7	3.5	88.9	31.8	40.5	4.0	101.6	37.6	46.3	4.5	114.3	43.4	52.1	5.0	127.0	49.2	57.8	5.5	139.7	55.0	63.6	6.0	152.4	60.7	69.4	6.5	165.1	66.5	75.2	7.0	177.8	72.3	81.0	7.5	190.5	78.1	86.8	8.0	203.2	83.9	92.6	8.5	215.9	89.7	98.3	9.0	228.6	95.4	104.1	9.5	241.3	101.2	109.9	10.0	254.0	107.0	115.7	10.5	266.7	112.8	121.5	11.0	279.4	118.6	127.3	11.5	292.1	124.4	133.0	12.0	304.8	130.2	138.8	12.5	317.5	135.9	144.6	13.0	330.2	141.7	150.4	13.5	342.9	147.5	156.2	14.0	355.6	153.3	162.0	14.5	368.3	159.1	167.8	15.0	381.0	164.9	173.5	15.5	393.7	170.6	179.3	16.0	406.4	176.4	185.1	16.5	419.1	182.2	190.9	17.0	431.8	188.0	196.7	17.5	444.5	193.8	202.5	18.0	457.2	199.6	208.2	18.5	469.9	205.4	214.0	19.0	482.6	211.1	219.8	19.5	495.3	216.9	225.6	20.0	508.0	222.7	231.4	20.5	520.7	228.5	237.2	21.0	533.4	234.3	243.0	21.5	546.1	240.1	248.7	22.0	558.8	245.8	254.5	22.5	571.5	251.6	260.3	23.0	584.2	254.5	266.1	23.5	596.9	260.3	271.9	24.0	609.6	266.1	277.7	24.5	622.3	271.9	283.4	25.0	635.0	277.7	289.2	25.5	647.7	283.4	295.0	26.0	660.4	289.2	300.8	26.5	673.1	295.0	306.6	27.0	685.8	300.8	312.4	27.5	698.5	306.6	318.2	28.0	711.2	312.4	323.9	28.5	723.9	318.2	329.7	29.0	736.6	323.9	335.5	29.5	749.3	329.7	341.3	30.0	762.0	335.5	347.1	30.5	774.7	341.3	352.9	31.0	787.4	347.1	358.6	31.5	800.1	352.9	364.4	HEIGHT (IN)	HEIGHT (MM)	USABLE VOLUME (GAL)	TOTAL VOLUME (GAL)	0.5	12.7	0	5.8	1.0	25.4	2.9	11.6	1.5	38.1	8.7	17.3	2.0	50.8	14.4	23.1	2.5	63.5	20.2	28.9	3.0	76.2	26.0	34.7	3.5	88.9	31.8	40.5	4.0	101.6	37.6	46.2	4.5	114.3	43.3	52.0	5.0	127.0	49.1	57.8	5.5	139.7	54.9	63.6	6.0	152.4	60.7	69.3	6.5	165.1	66.5	75.1	7.0	177.8	72.2	80.9	7.5	190.5	78.0	86.7	8.0	203.2	83.8	92.5	8.5	215.9	89.6	98.2	9.0	228.6	95.3	104.0	9.5	241.3	101.1	109.8	10.0	254.0	106.9	115.6	10.5	266.7	112.7	121.4	11.0	279.4	118.5	127.1	11.5	292.1	124.2	132.9	12.0	304.8	130.0	138.7	12.5	317.5	135.8	144.5	13.0	330.2	141.6	150.2	13.5	342.9	147.4	156.0	14.0	355.6	153.1	161.8	14.5	368.3	158.9	167.6	15.0	381.0	164.7	173.4	15.5	393.7	170.5	179.1	16.0	406.4	176.3	184.9	16.5	419.1	182.0	190.7	17.0	431.8	187.8	196.5	17.5	444.5	193.6	202.3	18.0	457.2	199.4	208.0	18.5	469.9	205.1	213.8	19.0	482.6	210.9	219.6	19.5	495.3	216.7	225.4	20.0	508.0	222.5	231.2	20.5	520.7	228.3	236.9	21.0	533.4	234.0	242.7	21.5	546.1	239.8	248.5	22.0	558.8	245.6	254.3	22.5	571.5	251.4	260.0	23.0	584.2	254.3	265.8	23.5	596.9	260.0	271.6	24.0	609.6	265.8	277.4	24.5	622.3	271.6	283.2	25.0	635.0	277.4	289.0	25.5	647.7	283.2	294.7	26.0	660.4	288.9	300.5	26.5	673.1	294.7	306.3	27.0	685.8	300.5	312.1	27.5	698.5	306.3	317.8	28.0	711.2	312.1	323.6	28.5	723.9	317.8	329.4	29.0	736.6	323.6	335.2	29.5	749.3	329.4	340.9	30.0	762.0	335.2	346.7	30.5	774.7	340.9	352.5	31.0	787.4	346.7	358.3	31.5	800.1	352.5	364.1	32.0	812.8	358.3	369.8	32.5	825.5	364.1	375.6	33.0	838.2	369.8	381.4	33.5	850.9	375.6	387.2	34.0	863.6	381.4	393.0	34.5	876.3	387.2	398.7	35.0	889.0	393.0	404.5	35.5	901.7	398.7	410.3	36.0	914.4	404.5	416.1	36.5	927.1	410.3	421.9	37.0	939.8	416.1	427.6	37.5	952.5	421.9	433.4	38.0	965.2	427.6	439.2	38.5	977.9	433.4	445.0	39.0	990.6	439.2	450.7	39.5	1003.3	445.0	456.5	40.0	1016.0	450.7	462.3	40.5	1028.7	456.5	468.1	41.0	1041.4	462.3	473.9	41.5	1054.1	468.1	479.6	42.0	1066.8	473.9	485.4	42.5	1079.5	479.6	491.2	43.0	1092.2	485.4	497.0	43.5	1104.9	491.2	502.8	44.0	1117.6	497.0	508.5	44.5	1130.3	502.8	514.3	45.0	1143.0	508.5	520.1	45.5	1155.7	514.3	525.9	46.0	1168.4	520.1	531.6	46.5	1181.1	525.9	537.4	P O N M L K J I H G F E D C B A
	HEIGHT (IN)	HEIGHT (MM)	USABLE VOLUME (GAL)	TOTAL VOLUME (GAL)																																																																																																																																																																																																																																																																																																																																																																																																																																																																																																																																																																																																																																																																																																																																																																																																																																																																												
	0.5	12.7	0	5.8																																																																																																																																																																																																																																																																																																																																																																																																																																																																																																																																																																																																																																																																																																																																																																																																																																																																												
	1.0	25.4	2.9	11.6																																																																																																																																																																																																																																																																																																																																																																																																																																																																																																																																																																																																																																																																																																																																																																																																																																																																												
	1.5	38.1	8.7	17.4																																																																																																																																																																																																																																																																																																																																																																																																																																																																																																																																																																																																																																																																																																																																																																																																																																																																												
	2.0	50.8	14.4	23.1																																																																																																																																																																																																																																																																																																																																																																																																																																																																																																																																																																																																																																																																																																																																																																																																																																																																												
	2.5	63.5	20.2	28.9																																																																																																																																																																																																																																																																																																																																																																																																																																																																																																																																																																																																																																																																																																																																																																																																																																																																												
	3.0	76.2	26.0	34.7																																																																																																																																																																																																																																																																																																																																																																																																																																																																																																																																																																																																																																																																																																																																																																																																																																																																												
	3.5	88.9	31.8	40.4																																																																																																																																																																																																																																																																																																																																																																																																																																																																																																																																																																																																																																																																																																																																																																																																																																																																												
	4.0	101.6	37.5	46.2																																																																																																																																																																																																																																																																																																																																																																																																																																																																																																																																																																																																																																																																																																																																																																																																																																																																												
	4.5	114.3	43.3	52.0																																																																																																																																																																																																																																																																																																																																																																																																																																																																																																																																																																																																																																																																																																																																																																																																																																																																												
	5.0	127.0	49.1	57.8																																																																																																																																																																																																																																																																																																																																																																																																																																																																																																																																																																																																																																																																																																																																																																																																																																																																												
	5.5	139.7	54.9	63.6																																																																																																																																																																																																																																																																																																																																																																																																																																																																																																																																																																																																																																																																																																																																																																																																																																																																												
	6.0	152.4	60.6	69.3																																																																																																																																																																																																																																																																																																																																																																																																																																																																																																																																																																																																																																																																																																																																																																																																																																																																												
	6.5	165.1	66.4	75.1																																																																																																																																																																																																																																																																																																																																																																																																																																																																																																																																																																																																																																																																																																																																																																																																																																																																												
	7.0	177.8	72.2	80.9																																																																																																																																																																																																																																																																																																																																																																																																																																																																																																																																																																																																																																																																																																																																																																																																																																																																												
	7.5	190.5	78.0	86.6																																																																																																																																																																																																																																																																																																																																																																																																																																																																																																																																																																																																																																																																																																																																																																																																																																																																												
	8.0	203.2	83.7	92.4																																																																																																																																																																																																																																																																																																																																																																																																																																																																																																																																																																																																																																																																																																																																																																																																																																																																												
	8.5	215.9	89.5	98.2																																																																																																																																																																																																																																																																																																																																																																																																																																																																																																																																																																																																																																																																																																																																																																																																																																																																												
	9.0	228.6	95.3	104.0																																																																																																																																																																																																																																																																																																																																																																																																																																																																																																																																																																																																																																																																																																																																																																																																																																																																												
	9.5	241.3	101.1	109.8																																																																																																																																																																																																																																																																																																																																																																																																																																																																																																																																																																																																																																																																																																																																																																																																																																																																												
	10.0	254.0	106.8	115.6																																																																																																																																																																																																																																																																																																																																																																																																																																																																																																																																																																																																																																																																																																																																																																																																																																																																												
	10.5	266.7	112.6	121.3																																																																																																																																																																																																																																																																																																																																																																																																																																																																																																																																																																																																																																																																																																																																																																																																																																																																												
	11.0	279.4	118.4	127.1																																																																																																																																																																																																																																																																																																																																																																																																																																																																																																																																																																																																																																																																																																																																																																																																																																																																												
11.5	292.1	124.2	132.9																																																																																																																																																																																																																																																																																																																																																																																																																																																																																																																																																																																																																																																																																																																																																																																																																																																																													
12.0	304.8	129.9	138.7																																																																																																																																																																																																																																																																																																																																																																																																																																																																																																																																																																																																																																																																																																																																																																																																																																																																													
12.5	317.5	135.7	144.5																																																																																																																																																																																																																																																																																																																																																																																																																																																																																																																																																																																																																																																																																																																																																																																																																																																																													
13.0	330.2	141.5	150.2																																																																																																																																																																																																																																																																																																																																																																																																																																																																																																																																																																																																																																																																																																																																																																																																																																																																													
13.5	342.9	147.3	155.9																																																																																																																																																																																																																																																																																																																																																																																																																																																																																																																																																																																																																																																																																																																																																																																																																																																																													
14.0	355.6	153.0	161.7																																																																																																																																																																																																																																																																																																																																																																																																																																																																																																																																																																																																																																																																																																																																																																																																																																																																													
14.5	368.3	158.8	167.5																																																																																																																																																																																																																																																																																																																																																																																																																																																																																																																																																																																																																																																																																																																																																																																																																																																																													
15.0	381.0	164.6	173.3																																																																																																																																																																																																																																																																																																																																																																																																																																																																																																																																																																																																																																																																																																																																																																																																																																																																													
15.5	393.7	170.4	179.0																																																																																																																																																																																																																																																																																																																																																																																																																																																																																																																																																																																																																																																																																																																																																																																																																																																																													
16.0	406.4	176.1	184.8																																																																																																																																																																																																																																																																																																																																																																																																																																																																																																																																																																																																																																																																																																																																																																																																																																																																													
16.5	419.1	181.9	190.6																																																																																																																																																																																																																																																																																																																																																																																																																																																																																																																																																																																																																																																																																																																																																																																																																																																																													
17.0	431.8	187.7	196.4																																																																																																																																																																																																																																																																																																																																																																																																																																																																																																																																																																																																																																																																																																																																																																																																																																																																													
17.5	444.5	193.5	202.1																																																																																																																																																																																																																																																																																																																																																																																																																																																																																																																																																																																																																																																																																																																																																																																																																																																																													
18.0	457.2	199.2	207.9																																																																																																																																																																																																																																																																																																																																																																																																																																																																																																																																																																																																																																																																																																																																																																																																																																																																													
18.5	469.9	205.0	213.7																																																																																																																																																																																																																																																																																																																																																																																																																																																																																																																																																																																																																																																																																																																																																																																																																																																																													
19.0	482.6	210.8	219.5																																																																																																																																																																																																																																																																																																																																																																																																																																																																																																																																																																																																																																																																																																																																																																																																																																																																													
19.5	495.3	216.6	225.2																																																																																																																																																																																																																																																																																																																																																																																																																																																																																																																																																																																																																																																																																																																																																																																																																																																																													
20.0	508.0	222.3	231.0																																																																																																																																																																																																																																																																																																																																																																																																																																																																																																																																																																																																																																																																																																																																																																																																																																																																													
20.5	520.7	228.1	236.8																																																																																																																																																																																																																																																																																																																																																																																																																																																																																																																																																																																																																																																																																																																																																																																																																																																																													
21.0	533.4	233.9	242.6																																																																																																																																																																																																																																																																																																																																																																																																																																																																																																																																																																																																																																																																																																																																																																																																																																																																													
21.5	546.1	239.7	248.3																																																																																																																																																																																																																																																																																																																																																																																																																																																																																																																																																																																																																																																																																																																																																																																																																																																																													
22.0	558.8	245.4	254.1																																																																																																																																																																																																																																																																																																																																																																																																																																																																																																																																																																																																																																																																																																																																																																																																																																																																													
22.5	571.5	251.2	259.9																																																																																																																																																																																																																																																																																																																																																																																																																																																																																																																																																																																																																																																																																																																																																																																																																																																																													
23.0	584.2	254.1	265.7																																																																																																																																																																																																																																																																																																																																																																																																																																																																																																																																																																																																																																																																																																																																																																																																																																																																													
23.5	596.9	259.9	271.4																																																																																																																																																																																																																																																																																																																																																																																																																																																																																																																																																																																																																																																																																																																																																																																																																																																																													
HEIGHT (IN)	HEIGHT (MM)	USABLE VOLUME (GAL)	TOTAL VOLUME (GAL)																																																																																																																																																																																																																																																																																																																																																																																																																																																																																																																																																																																																																																																																																																																																																																																																																																																																													
0.5	12.7	0	5.8																																																																																																																																																																																																																																																																																																																																																																																																																																																																																																																																																																																																																																																																																																																																																																																																																																																																													
1.0	25.4	2.9	11.6																																																																																																																																																																																																																																																																																																																																																																																																																																																																																																																																																																																																																																																																																																																																																																																																																																																																													
1.5	38.1	8.7	17.4																																																																																																																																																																																																																																																																																																																																																																																																																																																																																																																																																																																																																																																																																																																																																																																																																																																																													
2.0	50.8	14.5	23.1																																																																																																																																																																																																																																																																																																																																																																																																																																																																																																																																																																																																																																																																																																																																																																																																																																																																													
2.5	63.5	20.2	28.9																																																																																																																																																																																																																																																																																																																																																																																																																																																																																																																																																																																																																																																																																																																																																																																																																																																																													
3.0	76.2	26.0	34.7																																																																																																																																																																																																																																																																																																																																																																																																																																																																																																																																																																																																																																																																																																																																																																																																																																																																													
3.5	88.9	31.8	40.5																																																																																																																																																																																																																																																																																																																																																																																																																																																																																																																																																																																																																																																																																																																																																																																																																																																																													
4.0	101.6	37.6	46.3																																																																																																																																																																																																																																																																																																																																																																																																																																																																																																																																																																																																																																																																																																																																																																																																																																																																													
4.5	114.3	43.4	52.1																																																																																																																																																																																																																																																																																																																																																																																																																																																																																																																																																																																																																																																																																																																																																																																																																																																																													
5.0	127.0	49.2	57.8																																																																																																																																																																																																																																																																																																																																																																																																																																																																																																																																																																																																																																																																																																																																																																																																																																																																													
5.5	139.7	55.0	63.6																																																																																																																																																																																																																																																																																																																																																																																																																																																																																																																																																																																																																																																																																																																																																																																																																																																																													
6.0	152.4	60.7	69.4																																																																																																																																																																																																																																																																																																																																																																																																																																																																																																																																																																																																																																																																																																																																																																																																																																																																													
6.5	165.1	66.5	75.2																																																																																																																																																																																																																																																																																																																																																																																																																																																																																																																																																																																																																																																																																																																																																																																																																																																																													
7.0	177.8	72.3	81.0																																																																																																																																																																																																																																																																																																																																																																																																																																																																																																																																																																																																																																																																																																																																																																																																																																																																													
7.5	190.5	78.1	86.8																																																																																																																																																																																																																																																																																																																																																																																																																																																																																																																																																																																																																																																																																																																																																																																																																																																																													
8.0	203.2	83.9	92.6																																																																																																																																																																																																																																																																																																																																																																																																																																																																																																																																																																																																																																																																																																																																																																																																																																																																													
8.5	215.9	89.7	98.3																																																																																																																																																																																																																																																																																																																																																																																																																																																																																																																																																																																																																																																																																																																																																																																																																																																																													
9.0	228.6	95.4	104.1																																																																																																																																																																																																																																																																																																																																																																																																																																																																																																																																																																																																																																																																																																																																																																																																																																																																													
9.5	241.3	101.2	109.9																																																																																																																																																																																																																																																																																																																																																																																																																																																																																																																																																																																																																																																																																																																																																																																																																																																																													
10.0	254.0	107.0	115.7																																																																																																																																																																																																																																																																																																																																																																																																																																																																																																																																																																																																																																																																																																																																																																																																																																																																													
10.5	266.7	112.8	121.5																																																																																																																																																																																																																																																																																																																																																																																																																																																																																																																																																																																																																																																																																																																																																																																																																																																																													
11.0	279.4	118.6	127.3																																																																																																																																																																																																																																																																																																																																																																																																																																																																																																																																																																																																																																																																																																																																																																																																																																																																													
11.5	292.1	124.4	133.0																																																																																																																																																																																																																																																																																																																																																																																																																																																																																																																																																																																																																																																																																																																																																																																																																																																																													
12.0	304.8	130.2	138.8																																																																																																																																																																																																																																																																																																																																																																																																																																																																																																																																																																																																																																																																																																																																																																																																																																																																													
12.5	317.5	135.9	144.6																																																																																																																																																																																																																																																																																																																																																																																																																																																																																																																																																																																																																																																																																																																																																																																																																																																																													
13.0	330.2	141.7	150.4																																																																																																																																																																																																																																																																																																																																																																																																																																																																																																																																																																																																																																																																																																																																																																																																																																																																													
13.5	342.9	147.5	156.2																																																																																																																																																																																																																																																																																																																																																																																																																																																																																																																																																																																																																																																																																																																																																																																																																																																																													
14.0	355.6	153.3	162.0																																																																																																																																																																																																																																																																																																																																																																																																																																																																																																																																																																																																																																																																																																																																																																																																																																																																													
14.5	368.3	159.1	167.8																																																																																																																																																																																																																																																																																																																																																																																																																																																																																																																																																																																																																																																																																																																																																																																																																																																																													
15.0	381.0	164.9	173.5																																																																																																																																																																																																																																																																																																																																																																																																																																																																																																																																																																																																																																																																																																																																																																																																																																																																													
15.5	393.7	170.6	179.3																																																																																																																																																																																																																																																																																																																																																																																																																																																																																																																																																																																																																																																																																																																																																																																																																																																																													
16.0	406.4	176.4	185.1																																																																																																																																																																																																																																																																																																																																																																																																																																																																																																																																																																																																																																																																																																																																																																																																																																																																													
16.5	419.1	182.2	190.9																																																																																																																																																																																																																																																																																																																																																																																																																																																																																																																																																																																																																																																																																																																																																																																																																																																																													
17.0	431.8	188.0	196.7																																																																																																																																																																																																																																																																																																																																																																																																																																																																																																																																																																																																																																																																																																																																																																																																																																																																													
17.5	444.5	193.8	202.5																																																																																																																																																																																																																																																																																																																																																																																																																																																																																																																																																																																																																																																																																																																																																																																																																																																																													
18.0	457.2	199.6	208.2																																																																																																																																																																																																																																																																																																																																																																																																																																																																																																																																																																																																																																																																																																																																																																																																																																																																													
18.5	469.9	205.4	214.0																																																																																																																																																																																																																																																																																																																																																																																																																																																																																																																																																																																																																																																																																																																																																																																																																																																																													
19.0	482.6	211.1	219.8																																																																																																																																																																																																																																																																																																																																																																																																																																																																																																																																																																																																																																																																																																																																																																																																																																																																													
19.5	495.3	216.9	225.6																																																																																																																																																																																																																																																																																																																																																																																																																																																																																																																																																																																																																																																																																																																																																																																																																																																																													
20.0	508.0	222.7	231.4																																																																																																																																																																																																																																																																																																																																																																																																																																																																																																																																																																																																																																																																																																																																																																																																																																																																													
20.5	520.7	228.5	237.2																																																																																																																																																																																																																																																																																																																																																																																																																																																																																																																																																																																																																																																																																																																																																																																																																																																																													
21.0	533.4	234.3	243.0																																																																																																																																																																																																																																																																																																																																																																																																																																																																																																																																																																																																																																																																																																																																																																																																																																																																													
21.5	546.1	240.1	248.7																																																																																																																																																																																																																																																																																																																																																																																																																																																																																																																																																																																																																																																																																																																																																																																																																																																																													
22.0	558.8	245.8	254.5																																																																																																																																																																																																																																																																																																																																																																																																																																																																																																																																																																																																																																																																																																																																																																																																																																																																													
22.5	571.5	251.6	260.3																																																																																																																																																																																																																																																																																																																																																																																																																																																																																																																																																																																																																																																																																																																																																																																																																																																																													
23.0	584.2	254.5	266.1																																																																																																																																																																																																																																																																																																																																																																																																																																																																																																																																																																																																																																																																																																																																																																																																																																																																													
23.5	596.9	260.3	271.9																																																																																																																																																																																																																																																																																																																																																																																																																																																																																																																																																																																																																																																																																																																																																																																																																																																																													
24.0	609.6	266.1	277.7																																																																																																																																																																																																																																																																																																																																																																																																																																																																																																																																																																																																																																																																																																																																																																																																																																																																													
24.5	622.3	271.9	283.4																																																																																																																																																																																																																																																																																																																																																																																																																																																																																																																																																																																																																																																																																																																																																																																																																																																																													
25.0	635.0	277.7	289.2																																																																																																																																																																																																																																																																																																																																																																																																																																																																																																																																																																																																																																																																																																																																																																																																																																																																													
25.5	647.7	283.4	295.0																																																																																																																																																																																																																																																																																																																																																																																																																																																																																																																																																																																																																																																																																																																																																																																																																																																																													
26.0	660.4	289.2	300.8																																																																																																																																																																																																																																																																																																																																																																																																																																																																																																																																																																																																																																																																																																																																																																																																																																																																													
26.5	673.1	295.0	306.6																																																																																																																																																																																																																																																																																																																																																																																																																																																																																																																																																																																																																																																																																																																																																																																																																																																																													
27.0	685.8	300.8	312.4																																																																																																																																																																																																																																																																																																																																																																																																																																																																																																																																																																																																																																																																																																																																																																																																																																																																													
27.5	698.5	306.6	318.2																																																																																																																																																																																																																																																																																																																																																																																																																																																																																																																																																																																																																																																																																																																																																																																																																																																																													
28.0	711.2	312.4	323.9																																																																																																																																																																																																																																																																																																																																																																																																																																																																																																																																																																																																																																																																																																																																																																																																																																																																													
28.5	723.9	318.2	329.7																																																																																																																																																																																																																																																																																																																																																																																																																																																																																																																																																																																																																																																																																																																																																																																																																																																																													
29.0	736.6	323.9	335.5																																																																																																																																																																																																																																																																																																																																																																																																																																																																																																																																																																																																																																																																																																																																																																																																																																																																													
29.5	749.3	329.7	341.3																																																																																																																																																																																																																																																																																																																																																																																																																																																																																																																																																																																																																																																																																																																																																																																																																																																																													
30.0	762.0	335.5	347.1																																																																																																																																																																																																																																																																																																																																																																																																																																																																																																																																																																																																																																																																																																																																																																																																																																																																													
30.5	774.7	341.3	352.9																																																																																																																																																																																																																																																																																																																																																																																																																																																																																																																																																																																																																																																																																																																																																																																																																																																																													
31.0	787.4	347.1	358.6																																																																																																																																																																																																																																																																																																																																																																																																																																																																																																																																																																																																																																																																																																																																																																																																																																																																													
31.5	800.1	352.9	364.4																																																																																																																																																																																																																																																																																																																																																																																																																																																																																																																																																																																																																																																																																																																																																																																																																																																																													
HEIGHT (IN)	HEIGHT (MM)	USABLE VOLUME (GAL)	TOTAL VOLUME (GAL)																																																																																																																																																																																																																																																																																																																																																																																																																																																																																																																																																																																																																																																																																																																																																																																																																																																																													
0.5	12.7	0	5.8																																																																																																																																																																																																																																																																																																																																																																																																																																																																																																																																																																																																																																																																																																																																																																																																																																																																													
1.0	25.4	2.9	11.6																																																																																																																																																																																																																																																																																																																																																																																																																																																																																																																																																																																																																																																																																																																																																																																																																																																																													
1.5	38.1	8.7	17.3																																																																																																																																																																																																																																																																																																																																																																																																																																																																																																																																																																																																																																																																																																																																																																																																																																																																													
2.0	50.8	14.4	23.1																																																																																																																																																																																																																																																																																																																																																																																																																																																																																																																																																																																																																																																																																																																																																																																																																																																																													
2.5	63.5	20.2	28.9																																																																																																																																																																																																																																																																																																																																																																																																																																																																																																																																																																																																																																																																																																																																																																																																																																																																													
3.0	76.2	26.0	34.7																																																																																																																																																																																																																																																																																																																																																																																																																																																																																																																																																																																																																																																																																																																																																																																																																																																																													
3.5	88.9	31.8	40.5																																																																																																																																																																																																																																																																																																																																																																																																																																																																																																																																																																																																																																																																																																																																																																																																																																																																													
4.0	101.6	37.6	46.2																																																																																																																																																																																																																																																																																																																																																																																																																																																																																																																																																																																																																																																																																																																																																																																																																																																																													
4.5	114.3	43.3	52.0																																																																																																																																																																																																																																																																																																																																																																																																																																																																																																																																																																																																																																																																																																																																																																																																																																																																													
5.0	127.0	49.1	57.8																																																																																																																																																																																																																																																																																																																																																																																																																																																																																																																																																																																																																																																																																																																																																																																																																																																																													
5.5	139.7	54.9	63.6																																																																																																																																																																																																																																																																																																																																																																																																																																																																																																																																																																																																																																																																																																																																																																																																																																																																													
6.0	152.4	60.7	69.3																																																																																																																																																																																																																																																																																																																																																																																																																																																																																																																																																																																																																																																																																																																																																																																																																																																																													
6.5	165.1	66.5	75.1																																																																																																																																																																																																																																																																																																																																																																																																																																																																																																																																																																																																																																																																																																																																																																																																																																																																													
7.0	177.8	72.2	80.9																																																																																																																																																																																																																																																																																																																																																																																																																																																																																																																																																																																																																																																																																																																																																																																																																																																																													
7.5	190.5	78.0	86.7																																																																																																																																																																																																																																																																																																																																																																																																																																																																																																																																																																																																																																																																																																																																																																																																																																																																													
8.0	203.2	83.8	92.5																																																																																																																																																																																																																																																																																																																																																																																																																																																																																																																																																																																																																																																																																																																																																																																																																																																																													
8.5	215.9	89.6	98.2																																																																																																																																																																																																																																																																																																																																																																																																																																																																																																																																																																																																																																																																																																																																																																																																																																																																													
9.0	228.6	95.3	104.0																																																																																																																																																																																																																																																																																																																																																																																																																																																																																																																																																																																																																																																																																																																																																																																																																																																																													
9.5	241.3	101.1	109.8																																																																																																																																																																																																																																																																																																																																																																																																																																																																																																																																																																																																																																																																																																																																																																																																																																																																													
10.0	254.0	106.9	115.6																																																																																																																																																																																																																																																																																																																																																																																																																																																																																																																																																																																																																																																																																																																																																																																																																																																																													
10.5	266.7	112.7	121.4																																																																																																																																																																																																																																																																																																																																																																																																																																																																																																																																																																																																																																																																																																																																																																																																																																																																													
11.0	279.4	118.5	127.1																																																																																																																																																																																																																																																																																																																																																																																																																																																																																																																																																																																																																																																																																																																																																																																																																																																																													
11.5	292.1	124.2	132.9																																																																																																																																																																																																																																																																																																																																																																																																																																																																																																																																																																																																																																																																																																																																																																																																																																																																													
12.0	304.8	130.0	138.7																																																																																																																																																																																																																																																																																																																																																																																																																																																																																																																																																																																																																																																																																																																																																																																																																																																																													
12.5	317.5	135.8	144.5																																																																																																																																																																																																																																																																																																																																																																																																																																																																																																																																																																																																																																																																																																																																																																																																																																																																													
13.0	330.2	141.6	150.2																																																																																																																																																																																																																																																																																																																																																																																																																																																																																																																																																																																																																																																																																																																																																																																																																																																																													
13.5	342.9	147.4	156.0																																																																																																																																																																																																																																																																																																																																																																																																																																																																																																																																																																																																																																																																																																																																																																																																																																																																													
14.0	355.6	153.1	161.8																																																																																																																																																																																																																																																																																																																																																																																																																																																																																																																																																																																																																																																																																																																																																																																																																																																																													
14.5	368.3	158.9	167.6																																																																																																																																																																																																																																																																																																																																																																																																																																																																																																																																																																																																																																																																																																																																																																																																																																																																													
15.0	381.0	164.7	173.4																																																																																																																																																																																																																																																																																																																																																																																																																																																																																																																																																																																																																																																																																																																																																																																																																																																																													
15.5	393.7	170.5	179.1																																																																																																																																																																																																																																																																																																																																																																																																																																																																																																																																																																																																																																																																																																																																																																																																																																																																													
16.0	406.4	176.3	184.9																																																																																																																																																																																																																																																																																																																																																																																																																																																																																																																																																																																																																																																																																																																																																																																																																																																																													
16.5	419.1	182.0	190.7																																																																																																																																																																																																																																																																																																																																																																																																																																																																																																																																																																																																																																																																																																																																																																																																																																																																													
17.0	431.8	187.8	196.5																																																																																																																																																																																																																																																																																																																																																																																																																																																																																																																																																																																																																																																																																																																																																																																																																																																																													
17.5	444.5	193.6	202.3																																																																																																																																																																																																																																																																																																																																																																																																																																																																																																																																																																																																																																																																																																																																																																																																																																																																													
18.0	457.2	199.4	208.0																																																																																																																																																																																																																																																																																																																																																																																																																																																																																																																																																																																																																																																																																																																																																																																																																																																																													
18.5	469.9	205.1	213.8																																																																																																																																																																																																																																																																																																																																																																																																																																																																																																																																																																																																																																																																																																																																																																																																																																																																													
19.0	482.6	210.9	219.6																																																																																																																																																																																																																																																																																																																																																																																																																																																																																																																																																																																																																																																																																																																																																																																																																																																																													
19.5	495.3	216.7	225.4																																																																																																																																																																																																																																																																																																																																																																																																																																																																																																																																																																																																																																																																																																																																																																																																																																																																													
20.0	508.0	222.5	231.2																																																																																																																																																																																																																																																																																																																																																																																																																																																																																																																																																																																																																																																																																																																																																																																																																																																																													
20.5	520.7	228.3	236.9																																																																																																																																																																																																																																																																																																																																																																																																																																																																																																																																																																																																																																																																																																																																																																																																																																																																													
21.0	533.4	234.0	242.7																																																																																																																																																																																																																																																																																																																																																																																																																																																																																																																																																																																																																																																																																																																																																																																																																																																																													
21.5	546.1	239.8	248.5																																																																																																																																																																																																																																																																																																																																																																																																																																																																																																																																																																																																																																																																																																																																																																																																																																																																													
22.0	558.8	245.6	254.3																																																																																																																																																																																																																																																																																																																																																																																																																																																																																																																																																																																																																																																																																																																																																																																																																																																																													
22.5	571.5	251.4	260.0																																																																																																																																																																																																																																																																																																																																																																																																																																																																																																																																																																																																																																																																																																																																																																																																																																																																													
23.0	584.2	254.3	265.8																																																																																																																																																																																																																																																																																																																																																																																																																																																																																																																																																																																																																																																																																																																																																																																																																																																																													
23.5	596.9	260.0	271.6																																																																																																																																																																																																																																																																																																																																																																																																																																																																																																																																																																																																																																																																																																																																																																																																																																																																													
24.0	609.6	265.8	277.4																																																																																																																																																																																																																																																																																																																																																																																																																																																																																																																																																																																																																																																																																																																																																																																																																																																																													
24.5	622.3	271.6	283.2																																																																																																																																																																																																																																																																																																																																																																																																																																																																																																																																																																																																																																																																																																																																																																																																																																																																													
25.0	635.0	277.4	289.0																																																																																																																																																																																																																																																																																																																																																																																																																																																																																																																																																																																																																																																																																																																																																																																																																																																																													
25.5	647.7	283.2	294.7																																																																																																																																																																																																																																																																																																																																																																																																																																																																																																																																																																																																																																																																																																																																																																																																																																																																													
26.0	660.4	288.9	300.5																																																																																																																																																																																																																																																																																																																																																																																																																																																																																																																																																																																																																																																																																																																																																																																																																																																																													
26.5	673.1	294.7	306.3																																																																																																																																																																																																																																																																																																																																																																																																																																																																																																																																																																																																																																																																																																																																																																																																																																																																													
27.0	685.8	300.5	312.1																																																																																																																																																																																																																																																																																																																																																																																																																																																																																																																																																																																																																																																																																																																																																																																																																																																																													
27.5	698.5	306.3	317.8																																																																																																																																																																																																																																																																																																																																																																																																																																																																																																																																																																																																																																																																																																																																																																																																																																																																													
28.0	711.2	312.1	323.6																																																																																																																																																																																																																																																																																																																																																																																																																																																																																																																																																																																																																																																																																																																																																																																																																																																																													
28.5	723.9	317.8	329.4																																																																																																																																																																																																																																																																																																																																																																																																																																																																																																																																																																																																																																																																																																																																																																																																																																																																													
29.0	736.6	323.6	335.2																																																																																																																																																																																																																																																																																																																																																																																																																																																																																																																																																																																																																																																																																																																																																																																																																																																																													
29.5	749.3	329.4	340.9																																																																																																																																																																																																																																																																																																																																																																																																																																																																																																																																																																																																																																																																																																																																																																																																																																																																													
30.0	762.0	335.2	346.7																																																																																																																																																																																																																																																																																																																																																																																																																																																																																																																																																																																																																																																																																																																																																																																																																																																																													
30.5	774.7	340.9	352.5																																																																																																																																																																																																																																																																																																																																																																																																																																																																																																																																																																																																																																																																																																																																																																																																																																																																													
31.0	787.4	346.7	358.3																																																																																																																																																																																																																																																																																																																																																																																																																																																																																																																																																																																																																																																																																																																																																																																																																																																																													
31.5	800.1	352.5	364.1																																																																																																																																																																																																																																																																																																																																																																																																																																																																																																																																																																																																																																																																																																																																																																																																																																																																													
32.0	812.8	358.3	369.8																																																																																																																																																																																																																																																																																																																																																																																																																																																																																																																																																																																																																																																																																																																																																																																																																																																																													
32.5	825.5	364.1	375.6																																																																																																																																																																																																																																																																																																																																																																																																																																																																																																																																																																																																																																																																																																																																																																																																																																																																													
33.0	838.2	369.8	381.4																																																																																																																																																																																																																																																																																																																																																																																																																																																																																																																																																																																																																																																																																																																																																																																																																																																																													
33.5	850.9	375.6	387.2																																																																																																																																																																																																																																																																																																																																																																																																																																																																																																																																																																																																																																																																																																																																																																																																																																																																													
34.0	863.6	381.4	393.0																																																																																																																																																																																																																																																																																																																																																																																																																																																																																																																																																																																																																																																																																																																																																																																																																																																																													
34.5	876.3	387.2	398.7																																																																																																																																																																																																																																																																																																																																																																																																																																																																																																																																																																																																																																																																																																																																																																																																																																																																													
35.0	889.0	393.0	404.5																																																																																																																																																																																																																																																																																																																																																																																																																																																																																																																																																																																																																																																																																																																																																																																																																																																																													
35.5	901.7	398.7	410.3																																																																																																																																																																																																																																																																																																																																																																																																																																																																																																																																																																																																																																																																																																																																																																																																																																																																													
36.0	914.4	404.5	416.1																																																																																																																																																																																																																																																																																																																																																																																																																																																																																																																																																																																																																																																																																																																																																																																																																																																																													
36.5	927.1	410.3	421.9																																																																																																																																																																																																																																																																																																																																																																																																																																																																																																																																																																																																																																																																																																																																																																																																																																																																													
37.0	939.8	416.1	427.6																																																																																																																																																																																																																																																																																																																																																																																																																																																																																																																																																																																																																																																																																																																																																																																																																																																																													
37.5	952.5	421.9	433.4																																																																																																																																																																																																																																																																																																																																																																																																																																																																																																																																																																																																																																																																																																																																																																																																																																																																													
38.0	965.2	427.6	439.2																																																																																																																																																																																																																																																																																																																																																																																																																																																																																																																																																																																																																																																																																																																																																																																																																																																																													
38.5	977.9	433.4	445.0																																																																																																																																																																																																																																																																																																																																																																																																																																																																																																																																																																																																																																																																																																																																																																																																																																																																													
39.0	990.6	439.2	450.7																																																																																																																																																																																																																																																																																																																																																																																																																																																																																																																																																																																																																																																																																																																																																																																																																																																																													
39.5	1003.3	445.0	456.5																																																																																																																																																																																																																																																																																																																																																																																																																																																																																																																																																																																																																																																																																																																																																																																																																																																																													
40.0	1016.0	450.7	462.3																																																																																																																																																																																																																																																																																																																																																																																																																																																																																																																																																																																																																																																																																																																																																																																																																																																																													
40.5	1028.7	456.5	468.1																																																																																																																																																																																																																																																																																																																																																																																																																																																																																																																																																																																																																																																																																																																																																																																																																																																																													
41.0	1041.4	462.3	473.9																																																																																																																																																																																																																																																																																																																																																																																																																																																																																																																																																																																																																																																																																																																																																																																																																																																																													
41.5	1054.1	468.1	479.6																																																																																																																																																																																																																																																																																																																																																																																																																																																																																																																																																																																																																																																																																																																																																																																																																																																																													
42.0	1066.8	473.9	485.4																																																																																																																																																																																																																																																																																																																																																																																																																																																																																																																																																																																																																																																																																																																																																																																																																																																																													
42.5	1079.5	479.6	491.2																																																																																																																																																																																																																																																																																																																																																																																																																																																																																																																																																																																																																																																																																																																																																																																																																																																																													
43.0	1092.2	485.4	497.0																																																																																																																																																																																																																																																																																																																																																																																																																																																																																																																																																																																																																																																																																																																																																																																																																																																																													
43.5	1104.9	491.2	502.8																																																																																																																																																																																																																																																																																																																																																																																																																																																																																																																																																																																																																																																																																																																																																																																																																																																																													
44.0	1117.6	497.0	508.5																																																																																																																																																																																																																																																																																																																																																																																																																																																																																																																																																																																																																																																																																																																																																																																																																																																																													
44.5	1130.3	502.8	514.3																																																																																																																																																																																																																																																																																																																																																																																																																																																																																																																																																																																																																																																																																																																																																																																																																																																																													
45.0	1143.0	508.5	520.1																																																																																																																																																																																																																																																																																																																																																																																																																																																																																																																																																																																																																																																																																																																																																																																																																																																																													
45.5	1155.7	514.3	525.9																																																																																																																																																																																																																																																																																																																																																																																																																																																																																																																																																																																																																																																																																																																																																																																																																																																																													
46.0	1168.4	520.1	531.6																																																																																																																																																																																																																																																																																																																																																																																																																																																																																																																																																																																																																																																																																																																																																																																																																																																																													
46.5	1181.1	525.9	537.4																																																																																																																																																																																																																																																																																																																																																																																																																																																																																																																																																																																																																																																																																																																																																																																																																																																																													

Document Generated: 01APR2022 11:17 GMT

Cummins Data Classification:
Cummins Confidential

This document (and the information shown thereon) is
Confidential and Proprietary and shall not be disclosed to others
in hard copy or electronic form, reproduced by any means, or used
for any purpose without written consent of Cummins Inc.

Part Number: **A060C231** Part Revision: **D**
Part Name: **OUTLINE,TANK**
Drawing Category: **Outline** State: **Released** Sheet **5** of **6**

MODEL/PLATFORM: ARROW THIS PART IS SIMILAR TO: A064309
UNLESS OTHERWISE SPECIFIED THE FOLLOWING SHALL APPLY: ANG. TOL. +/- 1.0°
DIMENSIONAL TOLERANCES: X ± 0.004 (0.10), Y ± 0.004 (0.10), Z ± 0.004 (0.10)
DIMENSIONS ARE IN: MILLIMETERS SIZE: AO (SCALE: 1/2) CAD SYSTEM: PTC® Creo® Parametric
DIMENSIONING AND TOLERANCING PER: ASME Y14.5-2009 THIRD ANGLE PROJECTION

UNLESS OTHERWISE SPECIFIED,
ALL DIMENSIONS ARE IN INCHES

TOLERANCES:
FRACTIONAL: 1/4
X: .06
.XX: .03
.XXX: .01
ANGLES: .5

REFERENCES:
A060C858
A060C609
A060C611

A063C229
A060C231
A055B803

PREP. BY: KDU
CHKD BY: -
MODIFIED BY: -
FINISH: N/A

04/18/24

ENGINE FAMILY:
OSB7 ENGINE
BASIC FUEL TANK

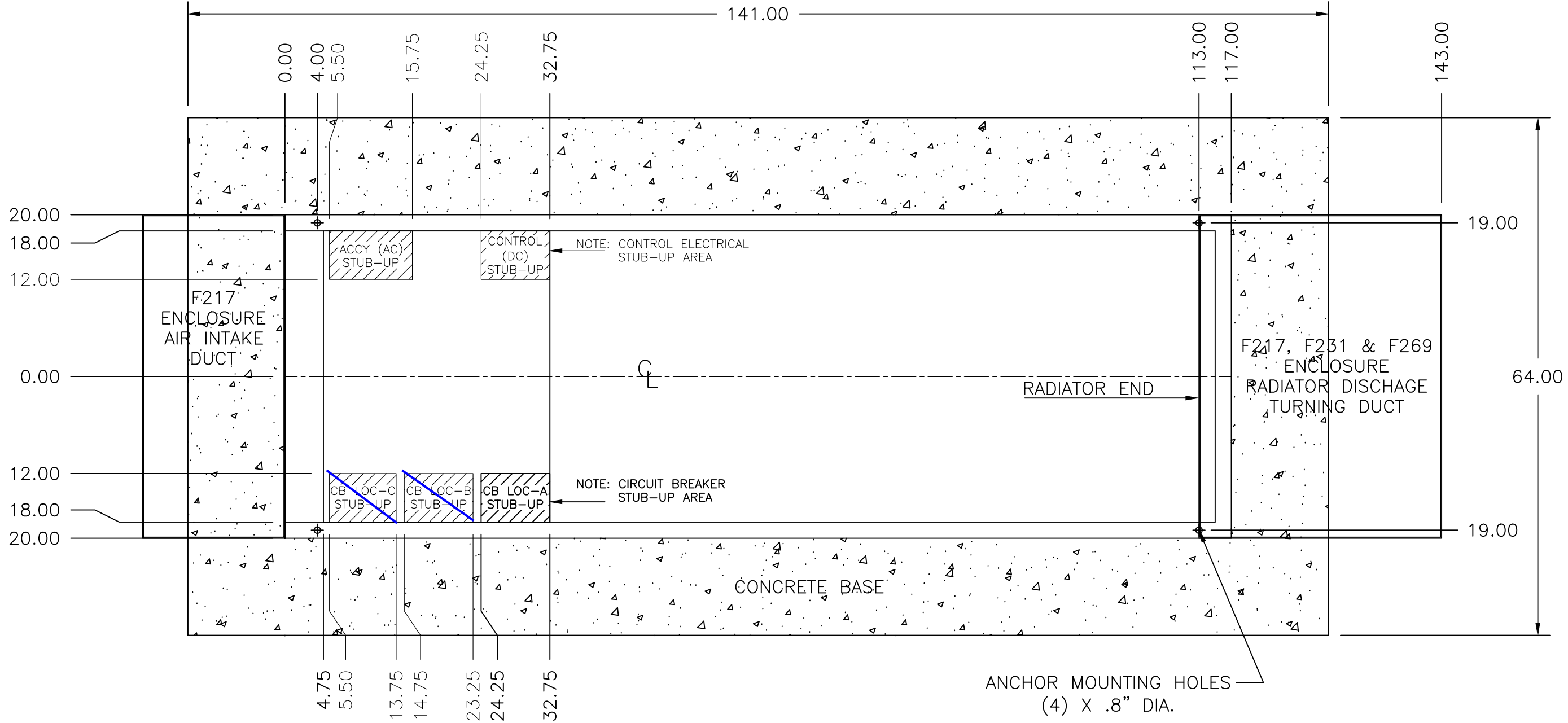

NOTE: SUGGESTED PAD LAYOUT SHOWN FOR REFERENCE.
SUGGESTED SERVICE ACCESS CLEARANCE 5 FEET.
ENCLOSURE INLET AIR FLOW SHALL BE UNOBSTRUCTED.
RADIATOR DISCHARGE AIR FLOW SHALL BE UNOBSTRUCTED.
F217 ENCLOSURE AIR INLET DUCT EXTENDS 17.6" BEYOND
GENERATOR SET SKID AND RADIATOR DISCHARGE DUCT
EXTENDS 26" BEYOND GENERATOR SET SKID.

REF: GENERATOR SET DRAWING A060C858
REF: GENERATOR SET/ENCLOSURE DRAWING A060C609
REF: GENERATOR SET/FUEL TANK DRAWING A060C231



SITE NAME: -		CONTACT NAME: -		CUSTOMER PROJECT NO: -		TITLE: 125 KW THRU 200 KW DIESEL GENERATOR SET ENCLOSURE & BASIC FUEL TANK	
CONTRACTOR NAME: -		CONTACT NO: -		CSSNA PROJECT NO: -		SIZE: C	DWG NO: C125 D6D THRU C200 D6D STUB-UP
						SCALE: NONE	DO NOT SCALE PRINT
						SHEET	1 OF 1

AC ACCESSORY LOAD TABLE

CUSTOMER AC CONNECTION TERMINALS

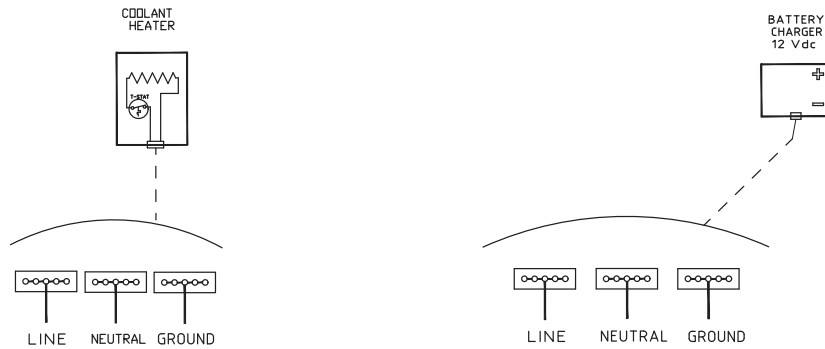

COOLANT HEATER 1500 WATTS, 120 VAC, 12.50 AMPS
 BATTERY CHARGER 192 WATTS, 120 VAC, 1.67 AMPS

NOTES:

1. INSTALLER TO PROVIDE BRANCH CIRCUITS TO POWER ALL ACCESSORIES
2. ALL ACCESSORIES ARE SINGLE PHASE 120/240 Vac 60 Hz
3. FOLLOW REGIONAL REGULATIONS AND APPLICABLE ELECTRIC CODES FOR INSTALLATION

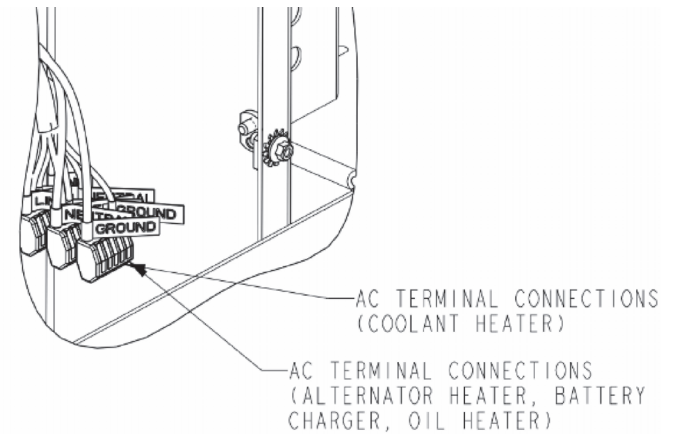

UNLESS OTHERWISE SPECIFIED,
ALL DIMENSIONS ARE IN INCHES

PREP. BY: JPK 12/3/2024



CSSNA POWER GEN

TITLE: C-SERIES AC LOAD TABLE

SIZE: B DWG NO:

SCALE:

DO NOT SCALE PRINT

SHEET

REV 3

1 OF 1

SECTION 5

Warranty





Warranty Statement

Global Commercial Warranty Statement

Generator Set

Limited Warranty

Commercial Generating Set

This limited warranty applies to all Cummins Power Generation® branded commercial generating sets and associated accessories (hereinafter referred to as "Product").

This warranty covers any failures of the Product, under normal use and service, which result from a defect in material or factory workmanship.

Warranty Period:

The warranty start date[†] is the date of initial start up, first rental, demonstration or 18 months after factory ship date, whichever is sooner. See table for details.

Continuous Power (COP) is defined as being the maximum power which the generating set is capable of delivering continuously whilst supplying a constant electrical load when operated for an unlimited number of hours per year. No overload capability is available for this rating.

Prime Power (PRP) is defined as being the maximum power which a generating set is capable of delivering continuously whilst supplying a variable electrical load when operated for an unlimited number of hours per year. The permissible average power output over 24 hours of operation shall not exceed 70% of the PRP. For applications requiring permissible average output higher than stated, a COP rating should be used.

Limited-Time Running Power (LTP) is defined as the maximum power available, under the agreed operating conditions, for which the generating set is capable of delivering for up to 500 hours of operation per year.

Emergency Standby Power (ESP) is defined as the maximum power available during a variable electrical power sequence, under the stated operating conditions, for which a generating set is capable of delivering in the event of a utility power outage or under test conditions for up to 500 hours of operation per year. The permissible average power output over 24 hours of operation shall not exceed 70% of the ESP.

Environmental Protection Agency – Stationary Emergency (EPA-SE) is defined as being the maximum power available during a variable electrical power sequence, under the stated operating conditions, for which a generator set is capable of delivering in the event of a utility power outage or under test conditions and used in strict accordance with the EPA NSPS for stationary engines, 40 CFR part 60, subparts IIII and JJJJ, where a reliable utility must be present. The permissible average power output over 24 hours of operation shall not exceed 70% of the EPA-SE.

Data Center Continuous (DCC) is defined as the maximum power which the generator is capable of delivering continuously to a constant or varying electrical load for unlimited hours in a data center application.

**Base Warranty Coverage Duration
(Whichever occurs first)**

Rating	Months	Max. Hours
COP	12	Unlimited
PRP	12	Unlimited
LTP	12	500 hrs
ESP	24	1000 hrs
EPA-SE	24	Unlimited
DCC	24	Unlimited

[†] Warranty start date for designated rental and oil and gas model Products is determined to be date of receipt of Product by the end customer.

Cummins Power Generation® Responsibilities:

In the event of a failure of the Product during the warranty period due to defects in material or workmanship, Cummins Power Generation® will only be responsible for the following costs:

- All parts and labor required to repair the Product.
- Reasonable travel expenses to and from the Product site location.
- Maintenance items that are contaminated or damaged by a warrantable failure.

Owner Responsibilities:

The owner will be responsible for the following:

- Notifying Cummins Power Generation® distributor or dealer within 30 days of the discovery of failure.
- Installing, operating, commissioning and maintaining the Product in accordance with Cummins Power Generation®'s published policies and guidelines.
- Providing evidence for date of commissioning.
- Providing sufficient access to and reasonable ability to remove the Product from the installation in the event of a warrantable failure.
- Incremental costs and expenses associated with Product removal and reinstallation resulting from non-standard installations.
- Costs associated with rental of generating sets used to replace the Product being repaired.
- Costs associated with labor overtime and premium shipping requested by the owner.
- All downtime expenses, fines, all applicable taxes, and other losses resulting from a warrantable failure.

Limitations:

This limited warranty does not cover Product failures resulting from:

- Inappropriate use relative to designated power rating.
- Inappropriate use relative to application guidelines.
- Inappropriate use of an EPA-SE application generator set relative to EPA's standards.
- Normal wear and tear.
- Improper and/or unauthorized installation.
- Negligence, accidents or misuse.
- Lack of maintenance or unauthorized repair.
- Noncompliance with any Cummins Power Generation® published guideline or policy.
- Use of improper or contaminated fuels, coolants or lubricants.
- Improper storage before and after commissioning.
- Owner's delay in making Product available after notification of potential Product problem.
- Replacement parts and accessories not authorized by Cummins Power Generation®.
- Use of Battle Short Mode.
- Owner or operator abuse or neglect such as: operation without adequate coolant or lubricants; overfueling; overspeeding; lack of maintenance to lubricating, cooling or air intake systems; late servicing and maintenance; improper storage, starting, warm-up, run-in or shutdown practices, or for progressive damage resulting from a defective shutdown or warning device.

- Damage to parts, fixtures, housings, attachments and accessory items that are not part of the generating set.

This limited warranty does not cover costs resulting from:

- Difficulty in gaining access to the Product.
- Damage to customer property.

A "Data center" is defined as a dedicated facility that house computers and associated equipment for data storage and data handling.

Reliable utility is defined as utility power without routine or regularly scheduled black-outs.

Please contact your local Cummins Power Generation® Distributor for clarification concerning these limitations.

CUMMINS POWER GENERATION® RIGHT TO FAILED COMPONENTS:

Failed components claimed under warranty remain the property of Cummins Power Generation®. Cummins Power Generation® has the right to reclaim any failed component that has been replaced under warranty.

Extended Warranty:

Cummins Power Generation® offers several levels of Extended Warranty Coverage. Please contact your local Cummins Power Generation® Distributor for details.

www.power.cummins.com

THE WARRANTIES SET FORTH HEREIN ARE THE SOLE WARRANTIES MADE BY CUMMINS POWER GENERATION® IN REGARD TO THE PRODUCT. CUMMINS POWER GENERATION® MAKES NO OTHER WARRANTIES, EXPRESS OR IMPLIED, OR OF MERCHANTABILITY OR FITNESS FOR A PARTICULAR PURPOSE.

IN NO EVENT IS CUMMINS POWER GENERATION® LIABLE FOR INCIDENTAL OR CONSEQUENTIAL DAMAGES.

This limited warranty shall be enforced to the maximum extent permitted by applicable law. This limited warranty gives the owner specific rights that may vary from state to state or from jurisdiction to jurisdiction.

Product Model Number: _____
 Product Serial Number: _____
 Date in Service: _____

power.cummins.com

Copyright © 2017 Cummins Inc. All rights reserved.

Cummins, the “C” logo, PowerCommand, AmpSentry, and InPower are trademarks of Cummins Inc.

Other company, product, or service names may be trademarks or service marks of others.

Specifications are subject to change without notice.

