



Installation Manual

Generator Set

QST30-G5 Engine with PowerCommand® 3.3 Control

DQFAA (Spec G-K)

DQFAB (Spec G-K)

DQFAC (Spec G-K)

DQFAD (Spec G-K)

Table of Contents

1. IMPORTANT SAFETY INSTRUCTIONS	1
1.1 Warning, Caution, and Note Styles Used in This Manual	1
1.2 General Information	1
1.2.1 General Safety Precautions	2
1.3 Generator Set Safety Code	5
1.3.1 Generator Set Operating Areas	5
1.3.2 Moving Parts Can Cause Severe Personal Injury or Death	5
1.3.3 Positioning of Generator Set.....	6
1.4 Electrical Shocks and Arc Flashes Can Cause Severe Personal Injury or Death.....	6
1.4.1 Locking the Generator Set Out of Service	7
1.4.2 AC Supply and Isolation.....	8
1.4.3 AC Disconnect Sources	8
1.5 Fuel and Fumes Are Flammable	9
1.5.1 Spillage	9
1.5.2 Fluid Containment.....	9
1.5.3 Do Not Operate in Flammable and Explosive Environments	9
1.6 Exhaust Gases Are Deadly.....	9
1.6.1 Exhaust Precautions	10
1.7 Earth Ground Connection	10
1.8 Decommissioning and Disassembly	11
2. INTRODUCTION.....	13
2.1 About This Manual	13
2.1.1 Additional Installation Manual Information	13
2.2 Schedule of Abbreviations	14
2.3 Related Literature	15
2.3.1 Further Information - Literature	16
2.4 After Sales Services.....	16
2.4.1 Maintenance.....	16
2.4.2 Warranty.....	17
3. SYSTEM OVERVIEW	19
3.1 Generator Set Identification	19
3.1.1 Nameplate.....	19
3.1.2 Generator Set Components	19
3.2 Generator Set Rating	20
3.3 Derating Factors	20
3.4 Engine Components	21
3.5 System Options.....	22
3.5.1 Introduction	22
3.5.2 Battery Charger.....	22
3.5.3 Day Tank.....	23

3.5.4 Enclosures	23
3.5.5 Fuel Transfer Pump	24
3.5.6 Heaters.....	25
3.5.7 Remote Radiator Installation	26
3.5.8 Relays	26
3.5.9 Seismic Installation Requirements.....	26
3.5.10 Sensors.....	26
4. INSTALLATION OVERVIEW	29
4.1 Application and Installation	29
4.2 Safety Considerations.....	29
4.3 Standby Heating Devices.....	30
4.4 Product Modifications.....	30
4.5 Derating Factors	30
5. SPECIFICATIONS	31
5.1 Generator Set Specifications.....	31
5.2 Engine Fuel Consumption.....	32
6. INSTALLING THE GENERATOR SET	33
6.1 Transportation.....	33
6.2 Location	34
6.3 Moving the Generator Set.....	35
6.3.1 Rigging Instructions.....	36
6.4 Mounting	37
6.5 Access to Generator Set.....	38
6.6 Seismic Installation Notes.....	38
7. MECHANICAL CONNECTIONS	41
7.1 Fuel System.....	41
7.1.1 Fuel Return Restrictions (or Pressure) Limit.....	42
7.1.2 Fuel Line Connections	42
7.1.3 Engine Fuel Connections.....	43
7.1.4 Supply Tank	44
7.1.5 Fuel Inlet Pressure/Restriction Limit	45
7.1.6 Day Tank.....	45
7.1.7 Fuel Transfer Pump	46
7.1.8 Fuel Additives.....	46
7.2 Exhaust System	47
7.3 Ventilation and Cooling.....	51
7.4 Vents and Ducts.....	52
7.5 Dampers	53
7.6 Air Inlet and Outlet Openings.....	53
7.7 Remote Radiator Cooling	55
7.7.1 Remote Radiator Installation.....	55
7.8 Breakerless Conductor Connections	56
7.8.1 Overload and Short Circuit Protection of Generator	56

7.8.2 AmpSentry Protective Relay Time-Over Current Characteristic Curve	59
7.8.3 Coordination of Protective Devices.....	61
7.8.4 Additional AmpSentry Protective Relay Information	61
8. DC CONTROL WIRING	63
8.1 Guidelines for Customer Connections to the Control System	63
8.1.1 Digital Connections	64
8.1.2 Relay Connections.....	64
8.2 PowerCommand 3.3 Customer Connections	64
8.2.1 Configurable Outputs	64
8.2.2 Remote Start.....	64
8.2.3 Configurable Inputs.....	65
8.2.4 Remote Emergency Stop.....	65
8.3 Customer Relays	65
8.3.1 Location of Customer Relays.....	65
9. AC ELECTRICAL CONNECTIONS	67
9.1 AC Distribution Panel Connections.....	68
9.1.1 AC Distribution Panel.....	68
9.2 Transfer Switch.....	70
9.3 Alternator Voltage Connections	71
9.4 Load Connections	72
9.4.1 Generator Set Load Cable Installation.....	72
9.4.2 Cabling through Non-Ferrous Gland Plates.....	72
9.4.3 Cabling through Ferrous Gland Plates	72
9.4.4 Distribution Cables.....	73
9.5 Installation of s-CAN Network Cable	74
9.6 Load Balancing	76
9.7 Fuel Transfer Pump Installation.....	76
9.7.1 Fuel Transfer Pump Control AC Connections	76
9.8 Current Transformers.....	78
9.9 Coolant Heater.....	78
9.10 Alternator Heaters.....	78
9.10.1 Alternator Heater Connection	78
9.11 Control Box Heater	78
9.11.1 Control Box Heater Installation	78
9.12 Battery Commissioning - Maintenance Free.....	79
9.12.1 Safety Precautions.....	80
9.12.2 Pre-Commissioning Procedure	81
9.12.3 Filling the Battery with Electrolyte.....	81
9.12.4 Charging - Commissioning	81
9.12.5 Connecting the Battery to the Generator Set.....	82
9.12.6 Electrolyte - Specific Gravity and Temperature	82
9.13 Battery Charger.....	84
9.13.1 PowerCommand Battery Charger - 15 Amp at 12 Volt and 12 Amp at 24 Volt.....	84
9.14 Grounding	85

10. PRE-START PREPARATION.....	89
10.1 Initial Pre-start Checks.....	89
10.2 Electrical System	90
10.3 Battery Connections.....	90
10.4 Site-Specific Configuration.....	91
10.5 Starting.....	91
11. INSTALLATION CHECKLIST	93
11.1 Checklist	93
12. MANUFACTURING FACILITIES	97
12.1 How to Obtain Service	97
12.1.1 Locating a Distributor	97
APPENDIX A. ALTERNATOR RECONNECT DRAWING	99
A.1 Reconnect Drawing for HC Alternator	101
A.2 Alternator Reconnect Drawing.....	103
APPENDIX B. CUSTOMER CONNECTIONS	111
B.1 Control Wiring Diagrams (0630-3440).....	113
APPENDIX C. OUTLINE DRAWINGS.....	125
C.1 Generator Set Outline Drawing (A053G789) - Set Mounted Radiator.....	127
C.2 Generator Set Outline Drawing (A049K674) - Set Mounted Radiator	131
C.3 Generator Set Outline Drawing (A062H932) - Set Mounted Radiator	135
C.4 Generator Set Outline Drawing (A053G787) - Remote Radiator.....	139
C.5 Generator Set Outline Drawing (A062M281) - Remote Radiator.....	144
APPENDIX D. SEISMIC REQUIREMENTS.....	149
D.1 Seismic Installation Instructions (A045K403).....	151
APPENDIX E. WIRING DIAGRAMS.....	155
E.1 PCC3300 Wiring Diagram (A053C830).....	157
E.2 Outline Drawing and Schematic - Heater.....	165
E.3 Wiring of Optional Equipment.....	166
E.4 Wiring Diagram with PowerCommand 3.3 or PowerCommand 3.3MLD Control.....	168

1 IMPORTANT SAFETY INSTRUCTIONS

SAVE THESE INSTRUCTIONS. This manual contains important instructions that should be followed during installation and maintenance of the generator set and batteries.

Safe and efficient operation can be achieved only if the equipment is properly operated and maintained. Many accidents are caused by failure to follow fundamental rules and precautions.

1.1 Warning, Caution, and Note Styles Used in This Manual

The following safety styles and symbols found throughout this manual indicate potentially hazardous conditions to the operator, service personnel, or equipment.

 DANGER
<i>Indicates a hazardous situation that, if not avoided, will result in death or serious injury.</i>

 WARNING
<i>Indicates a hazardous situation that, if not avoided, could result in death or serious injury.</i>

 CAUTION
<i>Indicates a hazardous situation that, if not avoided, could result in minor or moderate injury.</i>

NOTICE
Indicates information considered important, but not hazard-related (e.g., messages relating to property damage).

1.2 General Information

This manual should form part of the documentation package supplied by Cummins with specific generator sets. In the event that this manual has been supplied in isolation, contact your authorized distributor.

NOTICE
It is in the operator's interest to read and understand all warnings and cautions contained within the documentation relevant to the generator set, its operation and daily maintenance.

1.2.1 General Safety Precautions

WARNING

Hot Pressurized Liquid

Contact with hot liquid can cause severe burns.

Do not open the pressure cap while the engine is running. Let the engine cool down before removing the cap. Turn the cap slowly and do not open it fully until the pressure has been relieved.

WARNING

Moving Parts

Moving parts can cause severe personal injury.

Use extreme caution around moving parts. All guards must be properly fastened to prevent unintended contact.

WARNING

Toxic Hazard

Used engine oils have been identified by some state and federal agencies to cause cancer or reproductive toxicity.

Do not ingest, breathe the fumes, or contact used oil when checking or changing engine oil. Wear protective gloves and face guard.

WARNING

Electrical Generating Equipment

Incorrect operation can cause severe personal injury or death.

Do not operate equipment when fatigued, or after consuming any alcohol or drug.

WARNING

Toxic Gases

Substances in exhaust gases have been identified by some state and federal agencies to cause cancer or reproductive toxicity.

Do not breathe in or come into contact with exhaust gases.

WARNING

Combustible Liquid

Ignition of combustible liquids is a fire or explosion hazard which can cause severe burns or death.

Do not store fuel, cleaners, oil, etc., near the generator set.

WARNING

High Noise Level

Generator sets in operation emit noise, which can cause hearing damage.

Wear appropriate ear protection at all times.

⚠ WARNING**Hot Surfaces**

Contact with hot surfaces can cause severe burns.

The unit is to be installed so that the risk of hot surface contact by people is minimized. Wear appropriate PPE when working on hot equipment and avoid contact with hot surfaces.

⚠ WARNING**Electrical Generating Equipment**

Incorrect operation and maintenance can result in severe personal injury or death.

Make sure that only suitably trained and experienced service personnel perform electrical and/or mechanical service.

⚠ WARNING**Toxic Hazard**

Ethylene glycol, used as an engine coolant, is toxic to humans and animals.

Wear appropriate PPE. Clean up coolant spills and dispose of used coolant in accordance with local environmental regulations.

⚠ WARNING**Combustible Liquid**

Ignition of combustible liquids is a fire or explosion hazard which can cause severe burns or death.

Do not use combustible liquids like ether.

⚠ WARNING**Automated Machinery**

Accidental or remote starting of the generator set can cause severe personal injury or death.

Isolate all auxiliary supplies and use an insulated wrench to disconnect the starting battery cables (negative [-] first).

⚠ WARNING**Fire Hazard**

Materials drawn into the generator set are a fire hazard. Fire can cause severe burns or death.

Make sure the generator set is mounted in a manner to prevent combustible materials from accumulating under the unit.

⚠ WARNING**Fire Hazard**

Accumulated grease and oil are a fire hazard. Fire can cause severe burns or death.

Keep the generator set and the surrounding area clean and free from obstructions. Repair oil leaks promptly.

⚠ WARNING**Fall Hazard**

Falls can result in severe personal injury or death.

Make sure that suitable equipment for performing tasks at height are used in accordance with local guidelines and legislation.

⚠ WARNING**Fire Hazard**

Materials drawn into the generator set are a fire hazard. Fire can cause severe burns or death.

Keep the generator set and the surrounding area clean and free from obstructions.

⚠ WARNING**Pressurized System**

Pressurized systems can rupture/leak which can result in severe personal injury or death.

Use appropriate lock out/tag out safety procedures to isolate from all energy sources before performing any service tasks. Use PPE.

⚠ WARNING**Confined Areas**

Confined spaces or areas with restricted access or potential to entrap can cause severe personal injury or death.

Use appropriate lock out/tag out safety procedures to isolate from all energy sources. Use PPE. Follow site specific lone worker protocols/permits to work.

⚠ CAUTION**Manual Handling Heavy Objects**

Handling heavy objects can cause severe personal injury.

Use appropriate lifting equipment and perform tasks with two people where doing so would make completion of the task safe.

⚠ CAUTION**Power Tools and Hand Tools**

Tools can cause cuts, abrasions, bruising, puncture injuries.

Only trained and experienced personnel should use power tools and hand tools. Use PPE.

⚠ CAUTION**Sharp Edges and Sharp Points**

Projecting corners/parts may cause cuts, abrasions and other personal injury.

Use PPE. Be aware of sharp edges and corners/sharp points. Cover/protect them.

NOTICE

Keep multi-type ABC fire extinguishers close by. Class A fires involve ordinary combustible materials such as wood and cloth. Class B fires involve combustible and flammable liquid fuels and gaseous fuels. Class C fires involve live electrical equipment. (Refer to NFPA No. 10 in the applicable region.)

NOTICE

Before performing maintenance and service procedures on enclosed generator sets, make sure the service access doors are secured open.

NOTICE

Stepping on the generator set can cause parts to bend or break, leading to electrical shorts, or to fuel leaks, coolant leaks, or exhaust leaks. Do not step on the generator set when entering or leaving the generator set room.

1.3 Generator Set Safety Code

Before operating the generator set, read the manuals and become familiar with them and the equipment. Safe and efficient operation can be achieved only if the equipment is properly operated and maintained. Many accidents are caused by failure to follow fundamental rules and precautions.

⚠ WARNING***Electrical Generating Equipment***

Incorrect operation and maintenance can result in severe personal injury or death.

Read and follow all Safety Precautions, Warnings, and Cautions throughout this manual and the documentation supplied with the generator set.

1.3.1 Generator Set Operating Areas

⚠ WARNING***Ejected Debris***

Debris ejected during destructive failure can cause serious injury or death by impact, severing or stabbing.

Do not to stand alongside the engine or alternator while the generator set is running.

- Operators must not stand alongside the engine or alternator while the generator set is running, unless the risks of doing so have been assessed and adequate mitigation steps have been taken.
- If there are operation/maintenance procedures that require spending time alongside the generator set when it is running, take every precaution to perform these tasks safely. Keep time spent performing these tasks to a minimum.
- Be aware of the product environment. Other equipment may be in operation or energized in the surrounding area.

1.3.2 Moving Parts Can Cause Severe Personal Injury or Death

- Keep hands, clothing, and jewelry away from moving parts. Do not wear loose clothing or jewelry in the vicinity of moving parts or while working on electrical equipment. Loose clothing and jewelry can become caught in moving parts.
- Before starting work on the generator set, disconnect the battery charger from its AC source, then disconnect the starting batteries using an insulated wrench, negative (–) cable first. This will prevent accidental starting.

- Make sure that fasteners on the generator set are secure. Tighten supports and clamps; keep guards in position over fans, drive belts, etc.
- If any adjustments must be made while the unit is running, use extreme caution around hot manifolds, moving parts, etc.

1.3.3 Positioning of Generator Set

The generator set should be placed on level ground with adequate open space around it. The immediate area around the generator set should be free of any flammable material.

NOTICE

Access or service doors must be closed and locked before repositioning, and they must remain locked during transportation and siting.

NOTICE

The generator set is capable of operating at inclines of up to ± 2.5 degrees.

1.4 Electrical Shocks and Arc Flashes Can Cause Severe Personal Injury or Death

WARNING

Electric Shock Hazard

Voltages and currents present an electrical shock hazard that can cause severe burns or death. Contact with exposed energized circuits with potentials of 50 Volts AC or 75 Volts DC or higher can cause electrical shock and electrical arc flash. Refer to standard NFPA 70E or equivalent safety standards in corresponding regions for details of the dangers involved and for the safety requirements.

Guidelines to follow when working on de-energized electrical systems:

- Use proper PPE. Do not wear jewelry and make sure that any conductive items are removed from pockets as these items can fall into equipment and the resulting short circuit can cause shock or burning. Refer to standard NFPA 70E for PPE standards.
- De-energize and lockout/tagout electrical systems prior to working on them. Lockout/Tagout is intended to prevent injury due to unexpected start-up of equipment or the release of stored energy. Please refer to *Locking the Generator Set Out of Service* section for more information.
- De-energize and lockout/tagout all circuits and devices before removing any protective shields or making any measurements on electrical equipment.
- Follow all applicable regional electrical and safety codes.

Guidelines to follow when working on energized electrical systems:

NOTICE

It is the policy of Cummins Inc. to perform all electrical work in a de-energized state. However, employees or suppliers may be permitted to occasionally perform work on energized electrical equipment only when qualified and authorized to do so and when troubleshooting, or if de-energizing the equipment would create a greater risk or make the task impossible and all other alternatives have been exhausted.

NOTICE

Exposed energized electrical work is only allowed as per the relevant procedures and must be undertaken by a Cummins authorized person with any appropriate energized work permit for the work to be performed while using proper PPE, tools and equipment.

In summary:

- Do not tamper with or bypass interlocks unless you are authorized to do so.
- Understand and assess the risks - use proper PPE. Do not wear jewelry and make sure that any conductive items are removed from pockets as these items can fall into equipment and the resulting short circuit can cause shock or burning. Refer to standard NFPA 70E for PPE standards.
- Make sure that an accompanying person who can undertake a rescue is nearby.

1.4.1 Locking the Generator Set Out of Service

Before any work is carried out for maintenance, etc., the generator set must be immobilized. Even if the generator set is put out of service by pressing the **Off** switch on the operator panel, the generator set cannot be considered safe to work on until the engine is properly immobilized, as detailed in the following procedures.

NOTICE

Refer also to the engine specific Operator Manual. This manual contains specific equipment instructions that may differ from the standard generator set.

1.4.1.1 Immobilizing for Safe Working

To immobilize the generator set:

1. Press the **Off** mode switch on the operator panel to shut down the generator set.
2. Press the **Emergency Stop** button. This prevents the generator set starting, regardless of the Start signal source and provides an additional safety step for immobilizing the generator set.

NOTICE

When the Emergency Stop button is pressed, the operator panel indicates a Shutdown condition. The red Shutdown status LED  illuminates and a message is displayed.

NOTICE

Do not cover Emergency stop button in any situation for easy accessibility

NOTICE

This condition is stored in the Fault History.

3. Isolate and lock off the starting battery/batteries.
4. As an additional precaution, thoroughly ventilate the plant room before disconnecting any leads.
5. Isolate and lock off the supply to the heater, where fitted.
6. Isolate and lock off the supply to the battery charger, where fitted.
7. Isolate the fuel supply to the engine.
8. Using an insulated wrench, disconnect the negative (-) cable first on the starting batteries and control system batteries (if separate).
9. Fit warning notices at each of the above points to indicate Maintenance in Progress — Plant Immobilized for Safe Working.

1.4.2 AC Supply and Isolation

NOTICE

Local electrical codes and regulations (for example, *BS EN 12601:2010 Reciprocating internal combustion engine driven generating sets*) may require the installation of a disconnect means for the generator set, either on the generator set or where the generator set conductors enter a facility.

NOTICE

The AC supply must have the correct over current and earth fault protection according to local electrical codes and regulations. This equipment must be earthed (grounded).

It is the sole responsibility of the customer to provide AC power conductors for connection to load devices and the means to isolate the AC input to the terminal box; these must comply with local electrical codes and regulations. Refer to the wiring diagram supplied with the generator set.

The disconnecting device is not provided as part of the generator set, and Cummins accepts no responsibility for providing the means of isolation.

1.4.2.1 AmpSentry

Generator sets with PC 3.3 control utilize AmpSentry™ protective relay which includes integral AC protective functions for the alternator and conductors, if conductors are rated for operation at a minimum of 100% of the generator nameplate rating.

1.4.3 AC Disconnect Sources

⚠ WARNING***Hazardous Voltage***

Contact with high voltages can cause severe electrical shock, burns, or death.

The equipment may have more than one source of electrical energy. Disconnecting one source without disconnecting the others presents a shock hazard. Before starting work, disconnect the equipment, and verify that all sources of electrical energy have been removed.

1.5 Fuel and Fumes Are Flammable

Fire, explosion, and personal injury or death can result from improper practices.

- Do not fill fuel tanks while the engine is running unless the tanks are outside the engine compartment. Fuel contact with hot engine or exhaust is a potential fire hazard.
- Do not permit any flame, cigarette, pilot light, spark, arcing equipment, or other ignition source near the generator set or fuel tank.
- Fuel lines must be adequately secured and free of leaks. Fuel connection at the engine should be made with an approved flexible line. Do not use copper piping on flexible lines as copper will become brittle if continuously vibrated or repeatedly bent.
- Make sure all fuel supplies have a positive (+) shutoff valve.
- Make sure the battery area has been well-ventilated prior to servicing near it. Lead-acid batteries emit a highly explosive hydrogen gas that can be ignited by arcing, sparking, smoking, etc.

1.5.1 Spillage

Any spillage that occurs during fueling, oil top-off, or oil change must be cleaned up before starting the generator set.

1.5.2 Fluid Containment

NOTICE

Where spillage containment is not part of a Cummins supply, it is the responsibility of the installer to provide the necessary containment to prevent contamination of the environment, especially water courses and sources.

Fluid containment is incorporated into the base of the generator set, it must be inspected at regular intervals. Any liquid present should be drained out and disposed of in accordance with local health and safety regulations. Failure to perform this action may result in spillage of liquids which could contaminate the surrounding area.

Any other fluid containment area must also be checked and emptied, as described above.

1.5.3 Do Not Operate in Flammable and Explosive Environments

Flammable vapor can cause an engine to overspeed and become difficult to stop, resulting in possible fire, explosion, severe personal injury, and death. Do not operate a generator set where a flammable vapor environment can be created, unless the generator set is equipped with an automatic safety device to block the air intake and stop the engine. The owners and operators of the generator set are solely responsible for operating the generator set safely. Contact your authorized Cummins distributor for more information.

1.6 Exhaust Gases Are Deadly

- Provide an adequate exhaust system to properly expel discharged gases away from enclosed or sheltered areas, and areas where individuals are likely to congregate. Visually and audibly inspect the exhaust system daily for leaks per the maintenance schedule. Make sure that exhaust manifolds are secured and not warped. Do not use exhaust gases to heat a compartment.
- Make sure the unit is well ventilated.

1.6.1 Exhaust Precautions

WARNING

Hot Exhaust Gases

Contact with hot exhaust gases can cause severe burns.

Wear personal protective equipment when working on equipment.

WARNING

Hot Surfaces

Contact with hot surfaces can cause severe burns.

The unit is to be installed so that the risk of hot surface contact by people is minimized. Wear appropriate PPE when working on hot equipment and avoid contact with hot surfaces.

WARNING

Toxic Gases

Inhalation of exhaust gases can cause asphyxiation and death.

Pipe exhaust gas outside and away from windows, doors, or other inlets to buildings. Do not allow exhaust gas to accumulate in habitable areas.

WARNING

Fire Hazard

Contaminated insulation is a fire hazard. Fire can cause severe burns or death.

Remove any contaminated insulation and dispose of it in accordance with local regulations.

The exhaust outlet may be sited at the top or bottom of the generator set. Make sure that the exhaust outlet is not obstructed. Personnel using this equipment must be made aware of the exhaust position. Position the exhaust away from flammable materials - in the case of exhaust outlets at the bottom, make sure that vegetation is removed from the vicinity of the exhaust.

The exhaust pipes may have some insulating covers fitted. If these covers become contaminated they must be replaced before the generator set is run.

To minimize the risk of fire, make sure the following steps are observed:

- Make sure that the engine is allowed to cool thoroughly before performing maintenance or operation tasks.
- Clean the exhaust pipe thoroughly.

1.7 Earth Ground Connection

The neutral of the generator set may be required to be bonded to earth ground at the generator set location, or at a remote location, depending on system design requirements. Consult the engineering drawings for the facility or a qualified electrical design engineer for proper installation.

NOTICE

The end user is responsible to make sure that the ground connection point surface area is clean and free of rust before making a connection.

NOTICE

The end user is responsible for making sure that an earthing arrangement that is compliant with local conditions is established and tested before the equipment is used.

1.8 Decommissioning and Disassembly

NOTICE

Decommissioning and disassembly of the generator set at the end of its working life must comply with local guidelines and legislation for disposal/recycling of components and contaminated fluids. This procedure must only be carried out by suitably trained and experienced service personnel. For more information contact your authorized distributor.

This page is intentionally blank.

2 Introduction

WARNING

Hazardous Voltage

Contact with high voltages can cause severe electrical shock, burns, or death.

Make sure that only a trained and experienced electrician makes generator set electrical output connections, in accordance with the installation instructions and all applicable codes.

WARNING

Electrical Generating Equipment

Faulty electrical generating equipment can cause severe personal injury or death.

Generator sets must be installed, certified, and operated by trained and experienced persons in accordance with the installation instructions and all applicable codes.

2.1 About This Manual

The purpose of this manual is to provide the users with sound, general information. It is for guidance and assistance with recommendations for correct and safe procedures, which may from time to time be updated. It is the user's responsibility to ensure they are aware of any updates to this guidance before commencing operational activities. Cummins shall not be liable for any operational consequences arising as a result of not following the guidance outlined in this manual, nor for any discretionary actions taken by the user in response to recommendations outlined in this manual.

The information contained within the manual is based on information available at the time of going to print. In line with Cummins policy of continuous development and improvement, information may change at any time without notice. The users should therefore make sure that before commencing any work, they have the latest information available. The latest version of this manual is available on QuickServe Online (<https://quickserve.cummins.com>).

Users are respectfully advised that, in the interests of good practice and safety, it is their responsibility to employ competent persons to carry out any installation work. Consult your authorized distributor for further installation information. It is essential that the utmost care is taken with the application, installation, and operation of any engine due to their potentially hazardous nature. Careful reference should also be made to other Cummins literature. A generator set must be operated and maintained properly for safe and reliable operation.

For further assistance, contact your authorized distributor.

2.1.1 Additional Installation Manual Information

The purpose of this manual is to provide the Installation Engineer with sound, general information for the installation of the generator set. Refer to the Generator Set Operator Manual for additional information which must also be read before operating the set.

This manual provides installation instructions for the generator set models listed on the front cover. This includes the following information:

- Mounting Recommendations - for fastening the generator set to a base and space requirements for normal operation and service.
- Mechanical and Electrical Connections - covers most aspects of the generator set installation.
- Prestart - checklist of items or procedures needed to prepare the generator set for operation.

- Installation Checklist - reference checks upon completion of the installation.

This manual does not provide application information for selecting a generator set or designing the complete installation. If it is necessary to design the various integrated systems (fuel, exhaust, cooling, etc.), additional information is required. Review standard installation practices. For engineering data specific to the generator set, refer to the Specification and Data Sheets. For application information, refer to Application Manual T-030, "Liquid Cooled Generator Sets." To find this manual online:

1. Go to powersuite.cummins.com
2. Click on **Login** on the Home page.
3. Click on **T-030**, Liquid Cooled Generator Set Application Manual under Application Manuals.

2.2 Schedule of Abbreviations

This list is not exhaustive. For example, it does not identify units of measure or acronyms that appear only in parameters, event/fault names, or part/accessory names.

ABBR.	DESCRIPTION	ABBR.	DESCRIPTION
AC	Alternating Current	LTS	Long Term Storage
AMF	Automatic Mains Failure	LVRT	Low Voltage Ride Through
AMP	AMP, Inc., part of Tyco Electronics	MCB	Main Generator set Circuit Breaker
ANSI	American National Standards Institute	MFM	Multifunction Monitor
ASOV	Automatic Shut Off Valve	Mil Std	Military Standard
ASTM	American Society for Testing and Materials (ASTM International)	MLD	Masterless Load Demand
ATS	Automatic Transfer Switch	MRS	Manual Remote Start
AVR	Automatic Voltage Regulator	NC	Normally Closed
AWG	American Wire Gauge	NC	Not Connected
CAN	Controlled Area Network	NFPA	National Fire Protection Agency
CB	Circuit Breaker	NO	Normally Open
CE	Conformité Européenne	NWF	Network Failure
CFM	Cubic Feet per Minute	OEM	Original Equipment Manufacturer
CGT	Cummins Generator Technologies	OOR	Out of Range
CMM	Cubic Meters per Minute	OORH / ORH	Out of Range High
CT	Current Transformer	OORL / ORL	Out of Range Low
D-AVR	Digital Automatic Voltage Regulator	PB	Push Button
DC	Direct Current	PCC	PowerCommand® Control
DEF	Diesel Exhaust Fluid	PGI	Power Generation Interface
DPF	Diesel Particulate Filter	PGN	Parameter Group Number

ABBR.	DESCRIPTION	ABBR.	DESCRIPTION
ECM	Engine Control Module	PI	Proportional/Integral
ECS	Engine Control System	PID	Proportional / Integral / Derivative
EMI	Electromagnetic interference	PLC	Programmable Logic Controller
EN	European Standard	PMG	Permanent Magnet Generator
EPS	Engine Protection System	PPE	Personal Protective Equipment
E-Stop	Emergency Stop	PT	Potential Transformer
FAE	Full Authority Electronic	PTC	Power Transfer Control
FMI	Failure Mode Identifier	PWM	Pulse-width Modulation
FRT	Fault Ride Through	RFI	Radio Frequency Interference
FSO	Fuel Shutoff	RH	Relative Humidity
Genset	Generator Set	RMS	Root Mean Square
GCB	Generator set Circuit Breaker	RTU	Remote Terminal Unit
GCP	Generator Control Panel	SAE	Society of Automotive Engineers
GND	Ground	SCR	Selective Catalytic Reduction
LCT	Low Coolant Temperature	SPN	Suspect Parameter Number
HMI	Human-machine Interface	SWL	Safe Working Load
IC	Integrated Circuit	SW_B+	Switched B+
ISO	International Organization for Standardization	UL	Underwriters Laboratories
LBNG	Lean-burn Natural Gas	UPS	Uninterruptible Power Supply
LCD	Liquid Crystal Display	VPS	Valve Proving System
LED	Light-emitting Diode		

2.3 Related Literature

Before any attempt is made to operate the generator set, the operator should take time to read all of the manuals supplied with the generator set, and to familiarize themselves with the warnings and operating procedures.

CAUTION

A generator set must be operated and maintained properly if you are to expect safe and reliable operation. The Operator manual includes a maintenance schedule and a troubleshooting guide.

The relevant manuals appropriate to your generator set are also available:

- Operator Manual for DQFAA, DQFAB, DQFAC, and DQFAD Generator Sets with PowerCommand® 3.3 Controller (A053U864)
- Installation Manual for DQFAA, DQFAB, DQFAC, and DQFAD Generator Sets with PowerCommand® 3.3 Controller (A053U867)

- Service Manual for DQFAA, DQFAB, DQFAC, and DQFAD Generator Sets with PowerCommand® 3.3 Controller (A053U869)
- Parts Manual for DQFAA, DQFAB, DQFAC, and DQFAD Generator Sets with PowerCommand® 3.3 Controller (961-0211)
- Service Manual for PowerCommand® 3.3 Controller (960-0670)
- Alternator Service Manual for HC Alternator (A040J849)
- Alternator Service Manual for P7 Alternator (A040J850)
- Common Manual for Preventative Maintenance Requirements for High Range Standby Diesel Generator Sets (A035G976)
- Engine Operator and Maintenance Manual for QST30-G5 Engine (3666134)
- *Specification and Data Sheets*
- Application Manual *T-030: Liquid Cooled Generator Sets* (A040S369)
- Parts Manual for HC Alternator (0900-9914)
- Parts Manual for P7 Alternator (0900-9912)
- Standard Repair Times - CJ Family (A029C347)
- Fuels for Cummins Engines Service Bulletin (3379001)
- Emissions Warranty Statement (A043G561)
- Warranty Manual (A040W374)
- Global Commercial Warranty Statement (A028U870)

2.3.1 Further Information - Literature

Contact your authorized distributor for more information regarding related literature for this product.

2.4 After Sales Services

Cummins offers a full range of maintenance and warranty services.

2.4.1 Maintenance

WARNING

Electrical Generating Equipment

Incorrect operation and maintenance can result in severe personal injury or death.

Make sure that only suitably trained and experienced service personnel perform electrical and/or mechanical service.

For expert generator set service at regular intervals, contact your local distributor. Each local distributor offers a complete maintenance contract package covering all items subject to routine maintenance, including a detailed report on the condition of the generator set. In addition, this can be linked to a 24-hour call-out arrangement, providing year-round assistance if necessary. Specialist engineers are available to maintain optimum performance levels from generator sets. Maintenance tasks should only be undertaken by trained and experienced technicians provided by your authorized distributor.

2.4.2 Warranty

For details of the warranty coverage for your generator set, refer to the Global Commercial Warranty Statement listed in the Related Literature section.

In the event of a breakdown, prompt assistance can normally be given by factory trained service technicians with resources to undertake all minor and many major repairs to equipment on site.

Extended warranty coverage is also available.

For further warranty details, contact your authorized service provider.

NOTICE

Damage caused by failure to follow the manufacturer's recommendations will not be covered by warranty. Contact your authorized service provider.

2.4.2.1 Warranty Limitations

For details of the warranty limitations for your generator set, refer to the warranty statement applicable to the generator set.

This page is intentionally blank.

3 System Overview

This section provides an overview of the generator set.

3.1 Generator Set Identification

Each generator set is provided with a nameplate similar to that shown below. The nameplate provides information unique to the generator set.

3.1.1 Nameplate

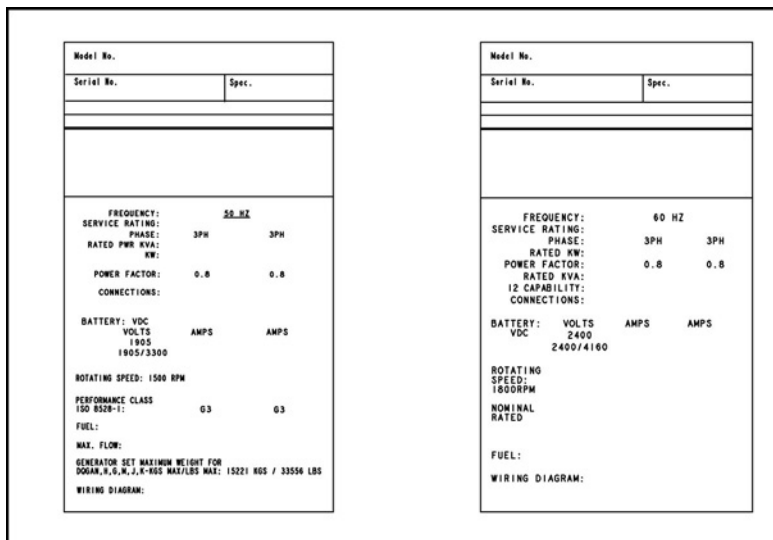

FIGURE 1. TYPICAL GENERATOR SET NAMEPLATE

3.1.2 Generator Set Components

The main components of a QST30-G5 engine generator set are shown below, and referred to within this section.

There are various options listed although they may not be available for all models.

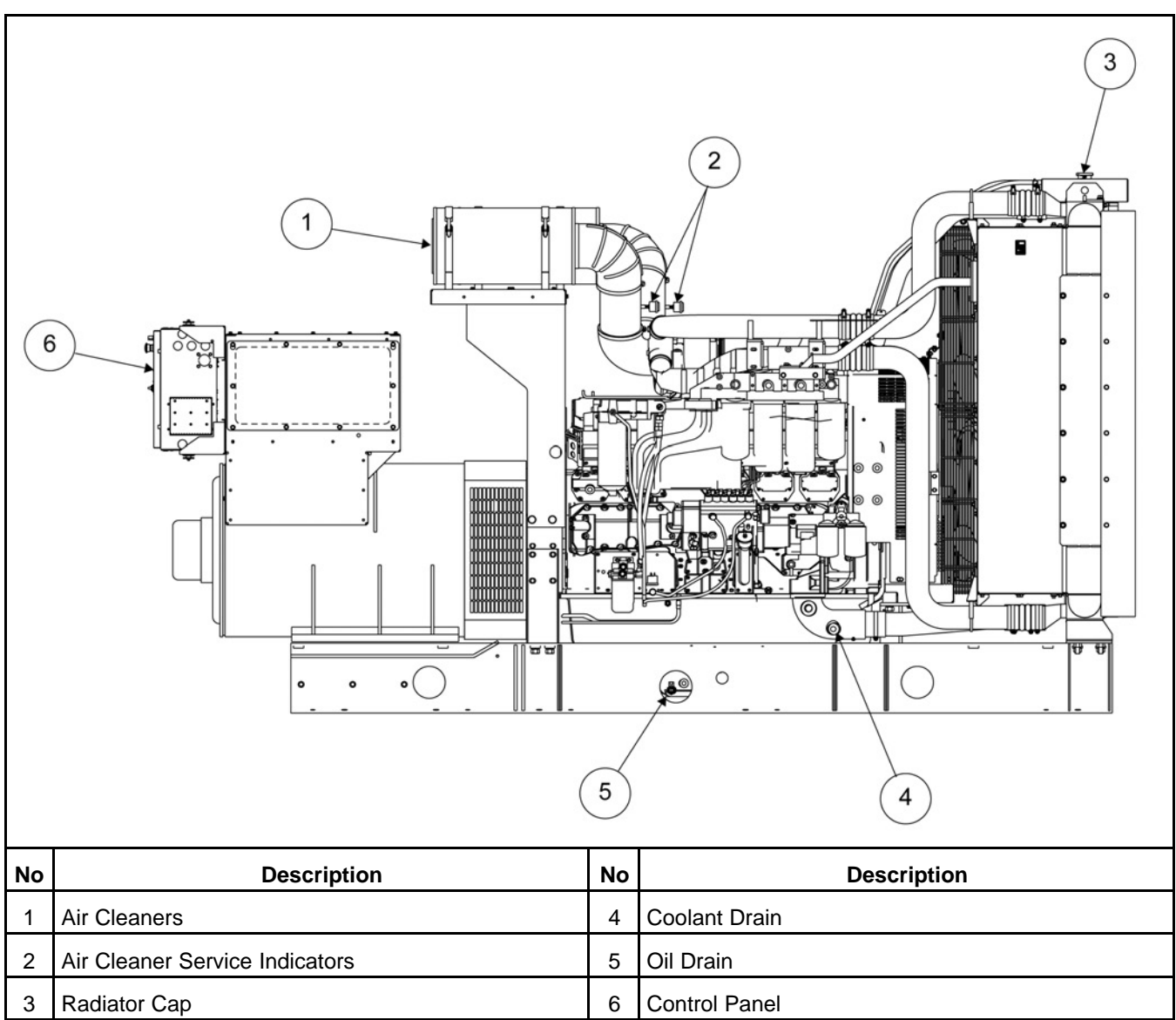

FIGURE 2. GENERATOR SET COMPONENTS

3.2 Generator Set Rating

For details of the generator set rating, refer to the generator set nameplate. For operation at temperatures or altitudes above those stated on the nameplate, a derate may be necessary.

3.3 Derating Factors

TABLE 1. DQFAA DERATING FACTOR

Application	Derating Factor
Prime	Engine power available up to 3150 m (10335 ft) at ambient temperatures up to 40 °C (104 °F) and 2630 m (8628 ft) at ambient temperatures up to 50 °C (122 °F). Above these elevations, derate at 3.5% per 305 m (1000 ft) and 7% per 10 °C (18 °F).

Standby	Engine power available up to 3200 m (10500 ft) at ambient temperatures up to 40 °C (104 °F) and 2200 m (7217 ft) at ambient temperatures up to 50 °C (122 °F). Above these elevations, derate at 3.5% per 305 m (1000 ft) and 7% per 10 °C (18 °F).
---------	---

TABLE 2. DQFAB DERATING FACTOR

Application	Derating Factor
Prime	Engine power available up to 2660 m (8727 ft) at ambient temperatures up to 40 °C (104 °F) and 2090 m (6856 ft) at ambient temperatures up to 50 °C (122 °F). Above these elevations, derate at 3.5% per 305 m (1000 ft) and 7% per 10 °C (18 °F)
Standby	Engine power available up to 2700 m (8858 ft) at ambient temperatures up to 40 °C (104 °F) and 1655 m (5429 ft) at ambient temperatures up to 50 °C (122 °F). Above these elevations, derate at 3.5% per 305 m (1000 ft) and 7% per 10 °C (18 °F)

TABLE 3. DQFAC DERATING FACTOR

Application	Derating Factor
Prime	Engine power available up to 1650 m (5413 ft) at ambient temperatures up to 40 °C (104 °F) and 975 m (3198 ft) at ambient temperatures up to 50 °C (122 °F). Above these elevations, derate at 3.5% per 305 m (1000 ft) and 7% per 10 °C (18 °F).
Standby	Engine power available up to 1720 m (5643 ft) at ambient temperatures up to 40 °C (104 °F) and 595 m (1952 ft) at ambient temperatures up to 50 °C (122 °F). Above these elevations, derate at 3.5% per 305 m (1000 ft) and 7% per 10 °C (18 °F)

TABLE 4. DQFAD DERATING FACTOR

Application	Derating Factor
Prime	Engine power available up to 727 m (2385 ft) at ambient temperatures up to 40 °C (104 °F). Above these elevations, derate at 3.5% per 305 m (1000 ft) and 7% per 10 °C (18 °F).
Standby	Engine power available up to 701 m (2300 ft) at ambient temperatures up to 40 °C (104 °F). Above these elevations, derate at 3.5% per 305 m (1000 ft) and 7% per 10 °C (18 °F).

3.4 Engine Components

For additional engine specific information, refer to the relevant engine manual for the generator set.

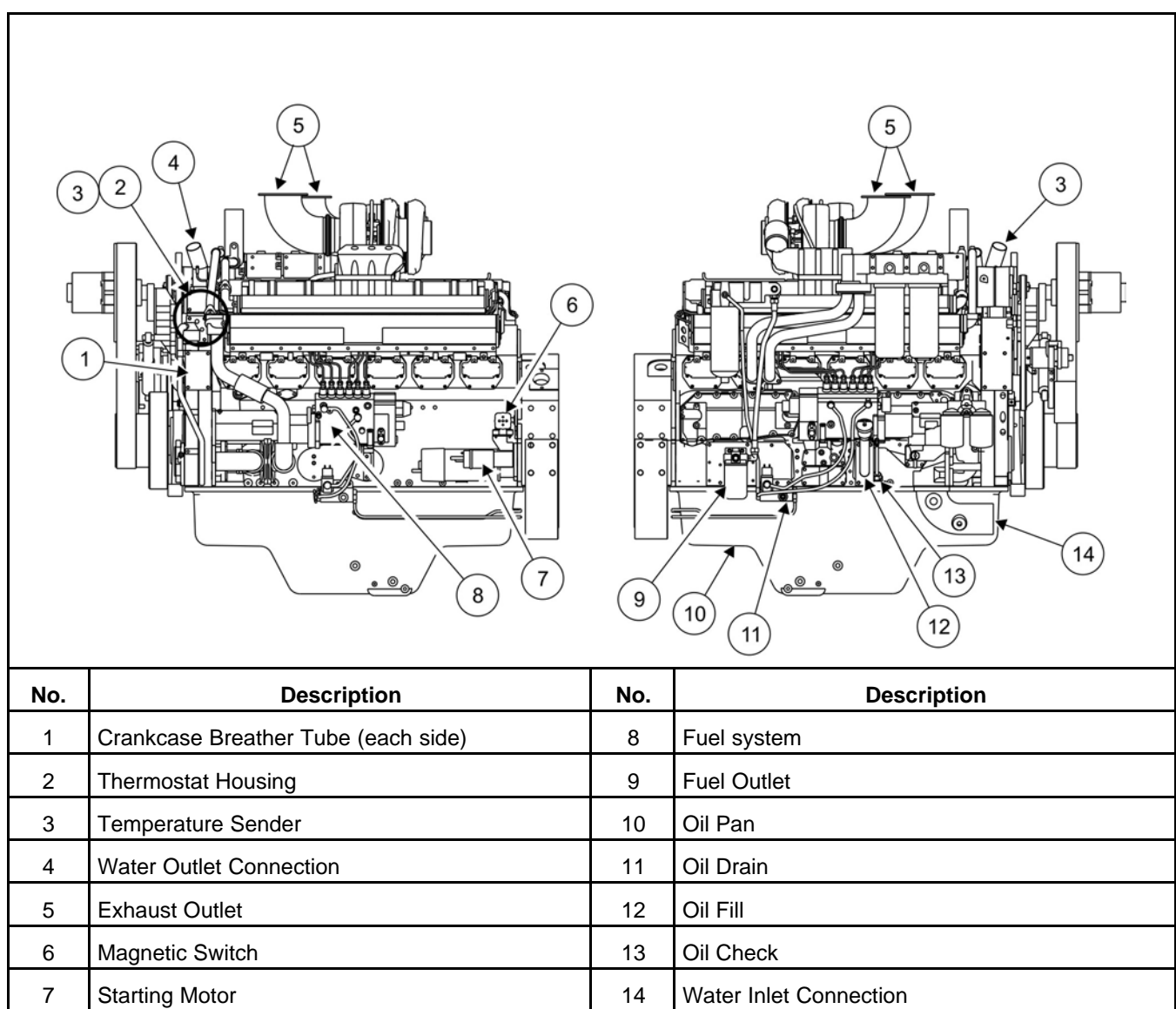

FIGURE 3. ENGINE COMPONENTS

3.5 System Options

3.5.1 Introduction

This section provides information for system options that require installation or customer connections before commissioning the generator set. For more information regarding system options, refer to the operator and service manual.

3.5.2 Battery Charger

Battery chargers can be wall, bench, or skid mounted. For more information, see [Section 9.13 on page 84](#).

3.5.3 Day Tank

Some generator set installations include a fuel day tank. For more information, refer to [Section 7.1.6 on page 45](#).

3.5.4 Enclosures

Enclosed generator sets can require optional features to be electrically connected during installation.

<i>NOTICE</i>
Use flexible conduit and stranded conductors for connections. Solid copper wire may break during generator set operation.

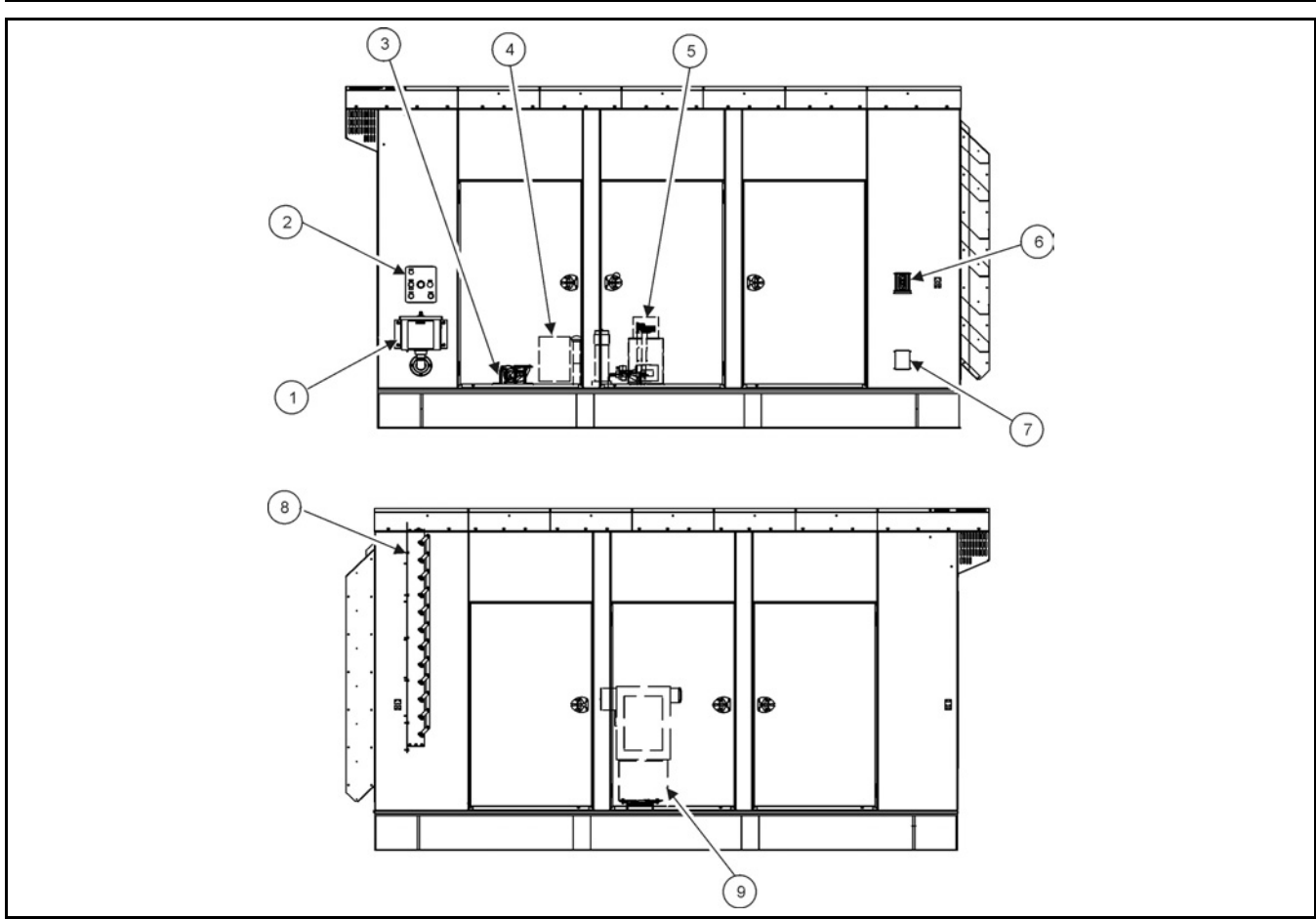

No.	Description	No.	Description
1	External Fuel Fill Box	6	Emergency Stop Switch
2	Fuel Alarm Panel	7	120 VAC External Receptacle
3	Overfill Alarm Assembly	8	Motorized Inlet Louver
4	Fuel Fill	9	AC Distribution Panel
5	Fuel System Control		

FIGURE 4. TYPICAL OPTIONAL ENCLOSURE FEATURES

3.5.5 Fuel Transfer Pump

NOTICE

Damage to the fuel transfer pump can occur if the pump operates with no fuel in the supply tank. Do not connect AC power to the fuel transfer pump control without having fuel in the supply tank.

NOTICE

Power to the fuel transfer pump must be fed from a transfer switch and step-down transformer to maintain 120V power to the pump when utility power is interrupted. Power must be supplied to the transfer pump during the time the generator set is running or not running.

The fuel pump/controller is pre-wired and ready to connect to a 120 VAC source.

NOTICE

When power is applied to the control or is restored after a power interruption, the control will automatically go to the power on mode (functions the same as pressing the ON switch). The pump starts if the control detects low fuel in the sub-base tank.

A fuel transfer pump and control are available when a sub-base fuel tank is provided. The automatic control operates the fuel pump to maintain a reservoir of fuel in the sub-base tank.

The fuel transfer pump has a maximum inlet restriction capability of 16 inch Hg, which is approximately equivalent to 20 feet of diesel.

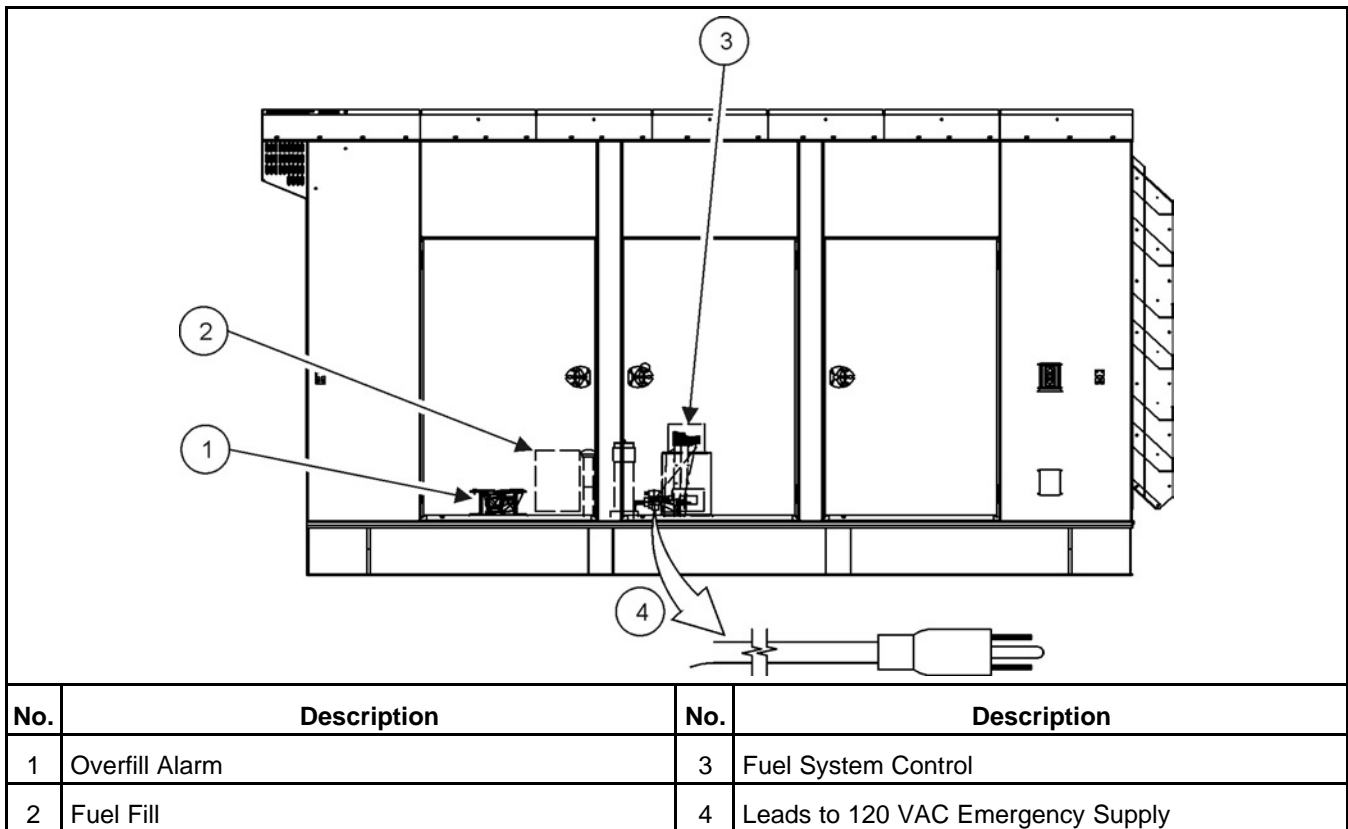

FIGURE 5. FUEL TRANSFER PUMP/CONTROL LOCATION

3.5.6 Heaters

3.5.6.1 Heater Supply and Isolation

An external power supply is required for the operation of the generator set heaters.

NOTICE

If not already provided, it is the sole responsibility of the customer to provide the power supply and the means to isolate the AC input to the terminal box. Cummins accepts no responsibility for providing the means of isolation.

3.5.6.2 Alternator Heaters

Alternator heaters are used to help keep the alternator free of condensation when the generator set is not running. For more information on alternator heater components and specifications, refer to [Section 9.10 on page 78](#).

3.5.6.3 Coolant Heater

Coolant heaters heat the coolant to maintain a minimum engine temperature when the generator set is not running.

3.5.6.4 Control Box Heater

A control box heater provides a means of humidity and temperature control of the control box interior. It protects the components when the generator set is subjected to varying ambient air conditions during extended periods of non-use. For more information on heater components and wiring, see [Section 9.11 on page 78](#).

3.5.7 Remote Radiator Installation

Special requirements apply if your generator set includes a remote radiator. For more information, refer to [Section 7.7 on page 55](#).

3.5.8 Relays

3.5.8.1 Customer Relays

These relays are used for customer-specific applications. For more information, see [Section 8.3 on page 65](#).

3.5.9 Seismic Installation Requirements

Seismically certified generator set installations have special requirements, as defined by IAA-VMC (Independent Approval Agency, the VMC Group).

For special installation requirements, refer to the tabulated and written seismic requirements listed in the Seismic Requirements appendix [Appendix D on page 149](#). The installation of the seismically certified generator set should be overseen by the installation project structural engineer of record.

The "Seismic Certificate of Compliance" should be kept with the Warranty and other generator set documents.

The seismic requirements installation drawing and the Seismic Certificate of Compliance for generator sets are included in the literature package of each seismically certified generator set.

3.5.10 Sensors

Various generator set parameters are measured by sensors, and the resulting signals are processed by the control board.

Typical sensors include, but are not limited to:

- Oil pressure
- Coolant level
- Fuel level
- Coolant temperature
- Lube oil temperature

- Alternator temperature

3.5.10.1 Pyrometers - Engine Exhaust

A pyrometer measures engine exhaust gas temperature. A separate temperature meter is used to monitor each exhaust outlet elbow.

3.5.10.1.1 Pyrometer Position

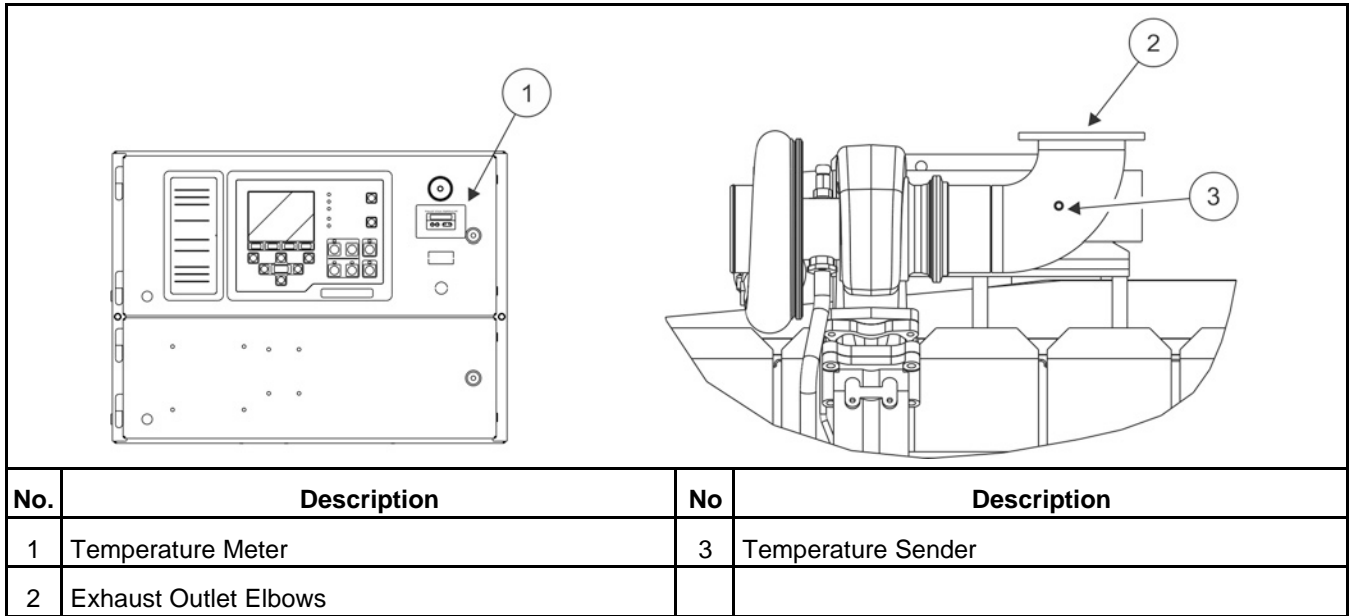

FIGURE 6. PYROMETER LOCATION AND METER

This page is intentionally blank.

4 Installation Overview

These installation recommendations apply to typical installations with standard model generator sets. Whenever possible, these recommendations also cover factory designed options or modifications. However, because of the many variables in any installation, it is not possible to provide specific recommendations for every situation. If there are any questions not answered by this manual, contact your nearest authorized distributor for assistance.

4.1 Application and Installation

A power system must be carefully planned and correctly installed for proper operation. This involves two essential elements.

- **Application** (as it applies to generator set installations) refers to the design of the complete power system that usually includes power distribution equipment, transfer switches, ventilation equipment, mounting pads, cooling, exhaust, and fuel systems. Each component must be correctly designed so the complete system will function as intended. Application and design is an engineering function generally done by specifying engineers or other trained specialists. Specifying engineers or other trained specialists are responsible for the design of the complete power system and for selecting the materials and products required.
 - Generator sets are designed and manufactured for specific environments.
 - Open generator sets are designed for use inside a building or plant where they will not be subjected to extreme environments.
 - Enclosed generator sets are designed for use outside, with features designed to enable operation in a wide range of climates.
- **Installation** refers to the actual set-up and assembly of the power system. The installers set up and connect the various components of the system as specified in the system design plan. The complexity of the system normally requires the special skills of qualified electricians, plumbers, sheet-metal workers, etc. to complete the various segments of the installation. This is necessary so that all components are assembled using standard methods and practices.

4.2 Safety Considerations

The generator set has been carefully designed to provide safe and efficient service when properly installed, maintained, and operated. However, the overall safety and reliability of the complete system is dependent on many factors outside the control of the generator set manufacturer. To avoid possible safety hazards, make all mechanical and electrical connections to the generator set exactly as specified in this manual. All systems external to the generator (fuel, exhaust, electrical, etc.) must comply with all applicable codes. Make certain all required inspections and tests have been completed and all code requirements have been satisfied before certifying the installation is complete and ready for service.

WARNING

Fall Hazard

Falls can result in severe personal injury or death.

Make sure that suitable equipment for performing tasks at height are used in accordance with local guidelines and legislation.

4.3 Standby Heating Devices

Cummins requires installing standby generator sets (life safety systems) with engine jacket water coolant heaters in order to ensure a 10 second start. Jacket water coolant heaters are also recommended in prime and continuous applications where time and load acceptance is to be minimized.

The jacket water coolant heater provided by Cummins rated to provide the above requirements in ambient temperatures as low as 4 °C (40 °F). Although most Cummins generator sets will start in temperatures down to -32 °C (-25 °F) when equipped with engine jacket water coolant heaters, it might take more than 10 seconds to warm the engine before a load can be applied when ambient temperatures are below 4 °C (40 °F).

On generator sets equipped with a graphic display, the **Low Coolant Temperature** message, in conjunction with illumination of the Warning LED, is provided to meet the current requirements. The engine cold sensing logic initiates a warning when the engine jacket water coolant temperature falls below 21 °C (70 °F). In applications where the ambient temperature falls below 4 °C (40 °F), or there exists a high amount of cold airflow, the jacket water coolant heater may not provide the necessary heating. Under these conditions, although the generator set may start, it may not be able to accept load within 10 seconds. When this condition occurs, check the coolant heaters for proper operation. If the coolant heaters are operating properly, other precautions may be necessary to warm the engine before applying a load.

4.4 Product Modifications

Agency certified products purchased from Cummins comply only with those specific requirements and as noted on company product specification sheets. Subsequent modifications must meet commonly accepted engineering practices and/or local and national codes and standards. Product modifications must be submitted to the local authority having jurisdiction for approval.

4.5 Derating Factors

Engine power and resulting electrical output decrease as ambient temperature or altitude increases. For derating factors applicable at specific sites, contact your authorized distributor.

5 Specifications

5.1 Generator Set Specifications

TABLE 5. DQFAA, DQFAB, DQFAC, AND DQFAD SPECIFICATIONS

MODELS	DQFAA	DQFAB	DQFAC	DQFAD
Engine				
Cummins Diesel Series	QST30-G5	QST30-G5	QST30-G5	QST30-G5
Generator kW Rating (Standby / Prime)	750/680	800/725	900/818	1000/900
Engine Fuel Connection				
Inlet/Outlet Thread Size	Refer to generator set outline drawing			
Maximum Weight				
AKG Cooling Package	15539 lbs (7048 kg)	16555 lbs (7509 kg)	16720 lbs (7584 kg)	16910 lb (7670 kg)
Bearward Cooling Package	15363 lbs (6971 kg)	15855 lbs (7194 kg)	16910 lbs (7672 kg)	17480 lb (7931 kg)
Fuel				
Max. Fuel Inlet Restriction	8 inHg (27 kPa)	8 inHg (27 kPa)	8 inHg (27 kPa)	8 inHg (27 kPa)
Max. Fuel Return Restriction with Set Mounted Radiator	20 inHg (67.5 kPa)	20 inHg (67.5 kPa)	20 inHg (67.5 kPa)	20 inHg (67.5 kPa)
Max. Fuel Return Restriction with Remote Radiator	20 inHg (67.5 kPa)	20 inHg (67.5 kPa)	20 inHg (67.5 kPa)	20 inHg (67.5 kPa)
Fuel Pump Flow Rate	150 gal/hr (570 L/hr)	150 gal/hr (570 L/hr)	150 gal/hr (570 L/hr)	150 gal/hr (570 L/hr)
Exhaust				
Outlet Size	6 in. NB	6 in. NB	6 in. NB	6 in. NB
Max. Allowable Back Pressure	27 in. H ₂ O (6.8 kPa)	27 in. H ₂ O (6.8 kPa)	27 in. H ₂ O (6.8 kPa)	27 in. H ₂ O (6.8 kPa)
Exhaust Flow at Rated Load	6310 cfm (177 m ³ /min)	6550 cfm (183 m ³ /min)	6950 cfm (195 m ³ /min)	7540 cfm (211 m ³ /min)
Exhaust Temperature	816 °F (435 °C)	833 °F (445 °C)	866 °F (463 °C)	890 °F (477 °C)
Electrical System				
Starting Voltage	24 Volts DC	24 Volts DC	24 Volts DC	24 Volts DC
Battery Group Number	8D	8D	8D	8D

MODELS	DQFAA	DQFAB	DQFAC	DQFAD
CCA (minimum)	1400	1400	1400	1400
Cooling System				
Capacity with AKG Set-mounted 50 °C Radiator	44.08 US gal (166.86 L)	44.08 US gal (166.86 L)	44.08 US gal (166.86 L)	44.08 US gal (166.86 L)
Capacity with Bearward Set-mounted 50 °C Radiator	53.2 US gal (201 L)	53.2 US gal (201 L)	53.2 US gal (201 L)	53.2 US gal (201 L)
Airflow: AKG manufactured prior to Sept 2016	54929 cfm (1555 m ³ /min)	54929 cfm (1555 m ³ /min)	54929 cfm (1555 m ³ /min)	54929 cfm (1555 m ³ /min)
Airflow: AKG manufactured post Sept 2016	39900 cfm (1130 m ³ /min)	39900 cfm (1130 m ³ /min)	39900 cfm (1130 m ³ /min)	39900 cfm (1130 m ³ /min)
Airflow: Bearward	35000 cfm (991 m ³ /min)	35000 cfm (991 m ³ /min)	35000 cfm (991 m ³ /min)	35000 cfm (991 m ³ /min)
Lubricating System				
Oil Capacity with Filters	162.8 qt (154 L)	162.8 qt (154 L)	162.8 qt (154 L)	162.8 qt (154 L)

5.2 Engine Fuel Consumption

TABLE 6. FUEL CONSUMPTION AT 1800 RPM (60 HZ)

QST30 Engine				
Model	DQFAA	DQFAB	DQFAC	DQFAD
Standby	199.5 L/Hr (52.7 US GPH)	213.5 L/Hr (56.4 US GPH)	241.9 L/Hr (63.9 US GPH)	273.3 L/Hr (72.2 US GPH)
Prime	181.3 L/Hr (47.9 US GPH)	193.1 L/Hr (51.0 US GPH)	218.4 L/Hr (57.7 US GPH)	241.9 L/Hr (63.9 US GPH)
Note: Fuel Consumption at Full Load, refer to Data Sheets for other applications. In line with the CPG policy of continuous improvement, these figures are subject to change.				

6 Installing the Generator Set

Generator set installations must be engineered so that the generator set will function properly under the expected load conditions. Use these instructions as a general guide only. Follow the instructions of the consulting engineer when locating or installing any components. The complete installation must comply with all local and state building codes, fire regulations, and other applicable regulations.

Requirements to be considered prior to installation are:

- Level mounting surface
- Adequate cooling air
- Adequate fresh induction air
- Discharge of generator set air
- Non-combustible mounting surface
- Discharge of exhaust gases
- Electrical connections
- Accessibility for operation and servicing
- Noise levels
- Vibration isolation
- Environmental conditions:
 - High and low temperatures, humidity
 - Rain and snowfall
 - Flood risk
 - Period of exposure to detrimental weather conditions
 - Wind

NOTICE

Depending on the location and intended use, ensure that international, national or local laws and regulations regarding Air Quality Emissions have been observed and complied with. Be sure to consult local pollution control or air quality authorities before completing construction plans.

6.1 Transportation

WARNING

Heavy Load

Incorrect lifting or repositioning can cause severe personal injury or death.

Make sure that only suitably trained and experienced personnel transport and handle generator sets and associated components.

⚠ WARNING**Heavy Load**

Incorrect lifting or repositioning can cause severe personal injury or death.

Do not lift the generator set by attaching to the engine or alternator lifting points. Do not stand under or near the generator set when lifting.

NOTICE

On an enclosed generator set, the canopy doors must be locked before re-positioning and must remain locked during transportation and siting.

- Ensure the generator set is prepared for transport. If necessary drain fluids and ensure that acid or fumes do not leak from the battery (where applicable).
- If the generator set is transported over long distances, protect it against environmental influences by sealing it in a plastic cover or similar.
- Ensure the generator set is secured to the vehicle with suitable securing straps. Wooden chocks and pallets alongside the securing straps can prevent movement during transportation.
- If required, attached impact indicators to the generator set. Upon delivery, check these impact indicators and contact the transport company immediately if an impact has been detected. Impacts can cause serious damage to the generator set and its components.
- Ensure that the generator set cannot turn over during transportation.
- Do not overload the transport vehicle. Under no circumstances should the generator set be started while inside a truck.
- Lifting eyes, where fitted, are to be checked at regular intervals to ensure they are damage free and tight.

6.2 Location

⚠ WARNING**Electrical Generating Equipment**

Incorrect operation and maintenance can result in severe personal injury or death.

Make sure that only suitably trained and experienced service personnel perform electrical and/or mechanical service.

⚠ WARNING**Incorrect installation**

Incorrect installation of the generator set, service or parts replacement, can result in severe personal injury, death, and/or equipment damage.

Service personnel must be trained and experienced to perform electrical and mechanical component installation.

NOTICE

Depending on your location and intended use, additional laws and regulations may require for you to obtain an air quality emissions permit before beginning installation of your generator set. Be sure to consult local pollution control or air quality authorities before completing your construction plans.

Generator set location is decided mainly by related systems such as ventilation, wiring, fuel, and exhaust. The set should be located as near as possible to the main power service entrance. Exhaust gases must not be able to enter or accumulate around inhabited areas.

Provide a location away from extreme ambient temperatures and protect the generator set from adverse weather conditions.

Use the following information to locate the generator set for optimal operating conditions:

Surface: Concrete or compacted gravel with the generator set resting on solid, poured concrete blocks, or timber blocks spaced at reasonable intervals around the perimeter of the generator set.

Leveling: Level the generator set from side-to-side within 3.5°, and end-to-end within 2.5°.

Placement:

- Generator sets should be a minimum of 5 m (16.4 ft) apart to allow for adequate access.
- Make sure that the air inlets are not obstructed by surrounding trees, buildings, or other obstructions.
- Make sure noise distribution (to prevent echoing) is kept to a minimum.
- Consider exhaust for immediate neighbors.
- The prevailing wind direction should be considered so that the engine combustion air inlet is upwind and the exhaust discharge is downwind.
- The immediate area around the proposed location of the mounting surface should be evaluated for proper drainage so that moisture run-off is sufficient to prevent ponding around the unit(s).

6.3 Moving the Generator Set

WARNING

Heavy Load

Incorrect lifting or repositioning can cause severe personal injury or death.

Make sure that only suitably trained and experienced personnel transport and handle generator sets and associated components.

WARNING

Heavy Load

Incorrect lifting or repositioning can cause severe personal injury or death.

Do not lift the generator set by attaching to the engine or alternator lifting points. Do not stand under or near the generator set when lifting.

WARNING

Mechanical Hazard

Failed components may be ejected or operate incorrectly which can cause severe personal injury or death.

Do not climb the generator set; this may damage critical parts.

NOTICE

Make sure that any shipping brackets supplied with the generator set are fitted, before moving the generator set. Failure to install the shipping brackets before moving may result in damage to the generator set.

NOTICE

Access or service doors must be closed and locked before repositioning, and they must remain locked during transportation and siting.

It is essential that there are sufficient trained and experienced personnel in attendance to make sure the lifting and transportation of the generator set is undertaken in a safe and appropriate manner, and in accordance to local guidelines and legislation.

Before lifting the generator set, lifting points, angle of slings, mass, access to intended site, and the distance of movement should all be taken into account when organizing a suitable crane/hoist. Consult the generator set information supplied with the generator set for details of dimensions and mass.

- Make sure the fuel tank is empty.
- Make sure that the crane operating area is able to support the mass of the crane and the generator set.
- Make sure the equipment used for lifting is adequate to support the weight of the generator set.
- Attach the lifting device to the lifting points only using suitable shackles, chains, and spreader bars.
- Slowly tighten the slings. Inspect the lifting attachments before commencing a full lift to make sure they are attached correctly.
- Hoist the generator set slowly using the indicated lifting points only.
- Guide the generator set with ropes at a safe distance to prevent uncontrolled rotation when positioning the generator set.
- Move the generator set to the desired location and place in position, bringing the set down slowly.
- Loosen the slings; unhook and remove the shackles.

6.3.1 Rigging Instructions

⚠ WARNING***Heavy Load***

Incorrect lifting or repositioning can cause severe personal injury or death.

Do not lift the generator set by attaching to the engine or alternator lifting points. Do not stand under or near the generator set when lifting.

⚠ WARNING***Heavy Load***

Incorrect lifting or repositioning can cause severe personal injury or death.

Make sure that only suitably trained and experienced personnel transport and handle generator sets and associated components.

1. Consult the generator set outline drawing for weight and center-of-gravity information.
2. Attach cables from the lifting lugs to a spreader bar. Never make the spreader bar cable attachment points wider than the attachment points on the skid or the bars. Make sure cables do not touch any other part of the generator set other than the skid.

NOTICE

Spreader bar cable attach points width "Y" must never be wider than skid cable attach points "X." Distance "X" is the narrowest width.

NOTICE

Angle B must be slightly greater than angle A. Angle B should be as close to 90 degrees as possible to provide a stable lift.

- With pedestal box (not shown), the spreader bars (front and back) should be used to clear the pedestal box and the attachment cables must be as vertical as possible.

NOTICE

The lifting angle (angle C) must not exceed 20° from vertical.

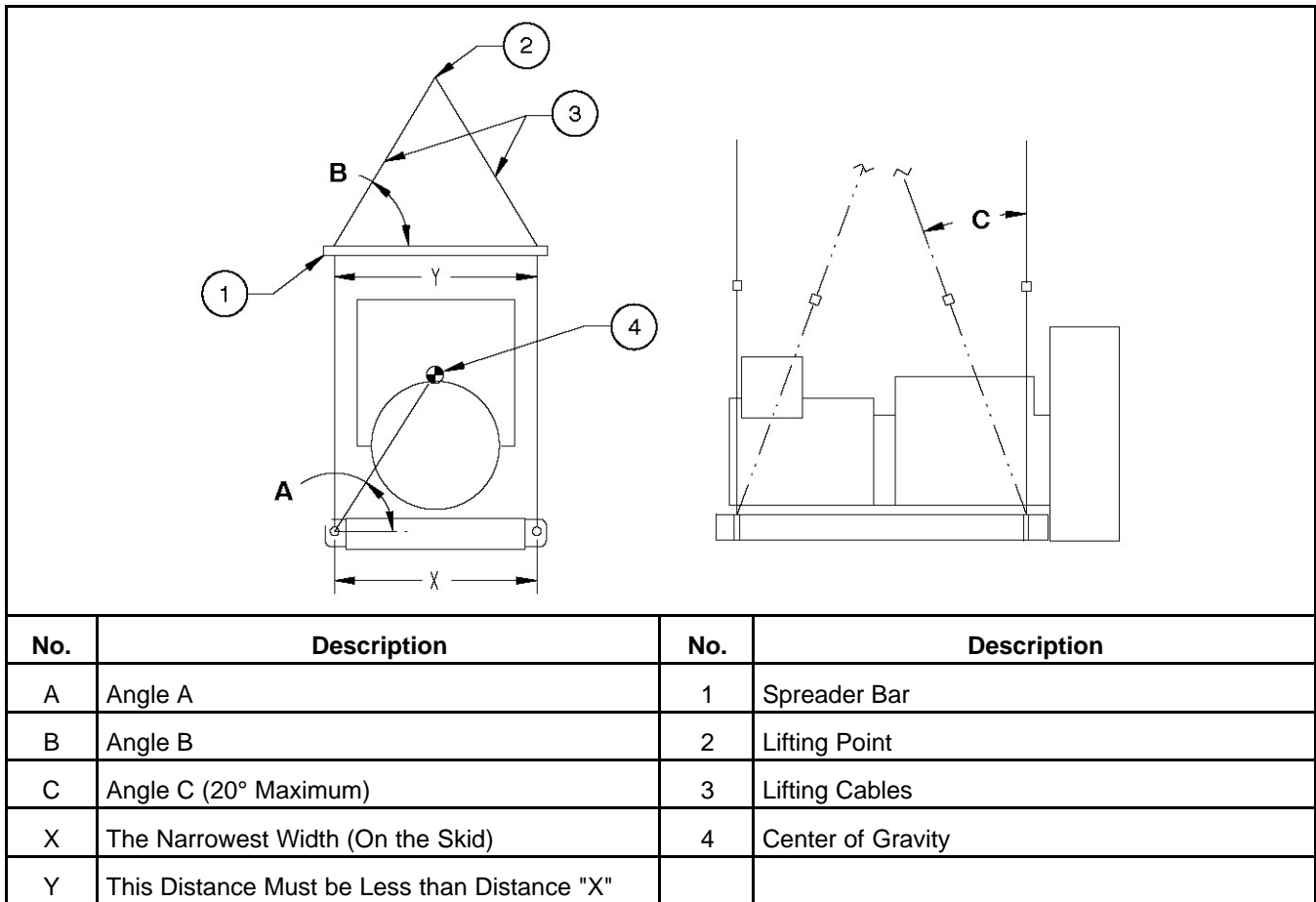

FIGURE 7. RIGGING

6.4 Mounting

Generator sets are mounted on a steel skid that provides proper support, which is sited on mechanical spring isolators to provide adequate vibration isolation per application.

NOTICE

The use of unapproved isolators may result in harmful resonances and may void the generator set warranty.

Mount the generator set on a substantial and level base such as a concrete pad. A non-combustible material must be used for the pad.

The fixing centers for the mounting bolts can be found on the generator set Outline Drawing.

6.5 Access to Generator Set

Generally, at least 1 meter (3.3 ft) of clearance should be provided on all sides of the generator set for maintenance and service access. (Increase clearance by width of door if optional housing is used.) A raised foundation or slab of 152 mm (6 inches) or more above floor level will make servicing easier. Lighting should be adequate for operation, maintenance and service operations and should be connected on the load side of the transfer switch so that it is available at all times.

6.6 Seismic Installation Notes

1. The design of post-installed anchors in concrete used for the component anchorage is pre-qualified for seismic applications in accordance with "ACI 355.2" and documented in a report by a reputable testing agency. (ex. the evaluation service report issued by the International Code Council)
2. Anchors must be installed to an embedment depth as recommended in the pre-qualification test report as defined in Note 1. For "IBC 2000" and "IBC 2003" applications, the minimum embedment must be 8X for the anchor diameter.
3. Anchors must be installed in minimum 4000 PSI compressive strength normal weight concrete. Concrete aggregate must comply with "ASTM C33". Installation in structural lightweight concrete is not permitted unless otherwise approved by the structural engineer of record.
4. Anchors must be installed to the torque specification as recommended by the anchor manufacturer to obtain maximum loading.
5. Anchors must be installed in locations specified in this section.
6. Wide washers must be installed at each anchor location between the anchor head and equipment for tension load distribution. Wide washers must be Series "W" of American National Standard Type "A" plain washers (ANSI B18.22.1-1965, R1975) with the nominal washer size selected to match the specified nominal anchor diameter.
7. Concrete floor slab and concrete housekeeping pads must be designed and rebar reinforced for seismic applications in accordance with "ACI 318". The design loads shall be taken as those specified in this section.
8. All housekeeping pad thicknesses must be designed in accordance with the pre-qualification test report as defined in Note 1 or a minimum of 1.5X the anchor embedment depth, whichever is largest.
9. All housekeeping pads must be dowelled or cast into the building structural floor slab and designed for seismic application per "ACI 318" and as approved by the structural engineer of record.
10. Wall mounted equipment must be installed to a rebar reinforced structural concrete wall that is seismically designed and approved by the engineer of record to resist the added seismic loads from components being anchored to the wall.
11. Floor mounted equipment (with or without a housekeeping pad) must be installed to a rebar reinforced structural concrete floor that is seismically designed and approved by the engineer of record to resist the added seismic loads from components being anchored to the floor.

12. When installing to a floor or wall, rebar interference must be considered.
13. Attaching seismic certified equipment to any floor or wall other than those constructed of structural concrete and designed to accept the seismic loads from said equipment is not permitted by this specification and beyond the scope of this certification.
14. Attaching seismic certified equipment to any floor constructed of light weight concrete over steel decking is not permitted by this specification and beyond the scope of this certification.
15. Attaching the seismic certified equipment to any concrete block walls or cinder block walls is not permitted by this specification and beyond the scope of this certification.
16. Installation upon a rooftop steel dunnage shall be coordinated with the structural engineer of record.
17. Installation upon any rooftop curb shall be coordinated with the curb manufacturer and the structural engineer of record. Any curb or concrete pad that supports the generator set unit is beyond the scope of this certification.
18. Connections to the equipment, including but not limited to conduit, wiring from cable trays, other electrical services, ducting, piping such as exhaust, steam, water, coolant, refrigerant, fuel, or other connections, are the responsibility of the installing contractor and beyond the scope of this document. Typical requirements for these connections are stated in the equipment installation manual. Special considerations for seismic applications are as follows; connections to non-isolated components or equipment may be installed as typical for that particular application. Connections to isolated components (ex. breaker box bolted directly to an isolated generator set) or isolated equipment (ex. an enclosed generator set mounted on external isolators) must be flexibly attached. The flexible attachment must provide for enough relative displacement to remain connected to the equipment and functional during and after a seismic event.

This page is intentionally blank.

7 Mechanical Connections

The generator set mechanical system installation includes connecting the fuel, exhaust, ventilation, and cooling systems. Before starting any type of fuel installation, all pertinent state and local codes must be complied with and the installation must be inspected before the unit is put in service.

7.1 Fuel System

Cummins engines normally use a diesel fuel specified to ASTM D975 grade 2 or BS EN 590:2000 is for automotive diesel, BS 2869:2010+A1:2011 Fuel oils for agricultural, domestic and industrial engines and boilers.

In all fuel system installations, cleanliness is of the utmost importance. Make every effort to prevent entrance of moisture, dirt, or contaminants of any kind into the fuel system. Clean all fuel system components before installing.

NOTICE

A fuel filter/strainer/water separator of 100-120 mesh or equivalent (approximately 150 microns nominal) must be fitted between either the main tank and day tank, or between the main tank and the engine.

Use only compatible metal fuel lines to avoid electrolysis when fuel lines must be buried. Buried fuel lines must be protected from corrosion.

NOTICE

Never use galvanized or copper fuel lines, fittings, or fuel tanks. Condensation in the tank and lines combines with the sulfur in diesel fuel to produce sulfuric acid. The molecular structure of the copper or galvanized lines or tanks reacts with the acid and contaminates the fuel.

An electric solenoid valve in the supply line is recommended for all installations and required for indoor automatic or remote starting installations. Connect the solenoid wires to the generator set "Switched B+" circuit to open the valve during generator set operation.

Separate fuel return lines to the day tank or supply tank must be provided for each generator set in a multiple-set installation to prevent the return lines of idle sets from being pressurized. Fuel return lines must not contain a shutoff device. Engine damage will occur if the engine is run with the return fuel lines blocked or restricted.

NOTICE

Never install a shutoff device in fuel return line(s). If fuel return line(s) is blocked or exceeds fuel restriction limit, engine damage will occur.

NOTICE

A base mounted fuel tank may be part of the generator set build. An additional external fuel system may be required if the on board fuel capacity is not sufficient for the application.

7.1.1 Fuel Return Restrictions (or Pressure) Limit

Fuel return drain restriction (consisting of friction head and static head) between the engine injector return line connection and the fuel tank must not exceed the limit stated in the model-specific generator set *Specification Sheet*.

7.1.2 Fuel Line Connections

WARNING

Combustible Liquid

Fuel leaks are a fire and explosion hazard which can cause severe personal injury or death.

Always use flexible tubing between the engine and fuel supply to avoid line failure and leaks due to vibration. The fuel system must meet all application codes.

WARNING

Combustible Liquid

Ignition of fuel is a fire and explosion hazard which can cause severe personal injury or death.

Do not route fuel lines near electrical wiring.

WARNING

Hot Surface

Hot surfaces can ignite fuel. Ignited fuel is a fire and explosion hazard which can cause severe burns or death.

Do not route fuel lines near hot exhaust parts.

NOTICE

Fuel lines must be routed and secured to maintain a 12.7 mm (½ inch) minimum clearance from electrical wiring and a 51 mm (2 inches) minimum clearance from hot exhaust parts.

Flexible lines for connecting between the engine and the skid mounted fuel tank (if fitted) are supplied as standard equipment.

Flexible lines for connecting between the engine and an external fuel supply must be used between the engine fuel system, and the fuel supply and return lines to protect the fuel system from damage caused by vibration, expansion, and contraction.

For additional information refer to T-030 Application Manual.

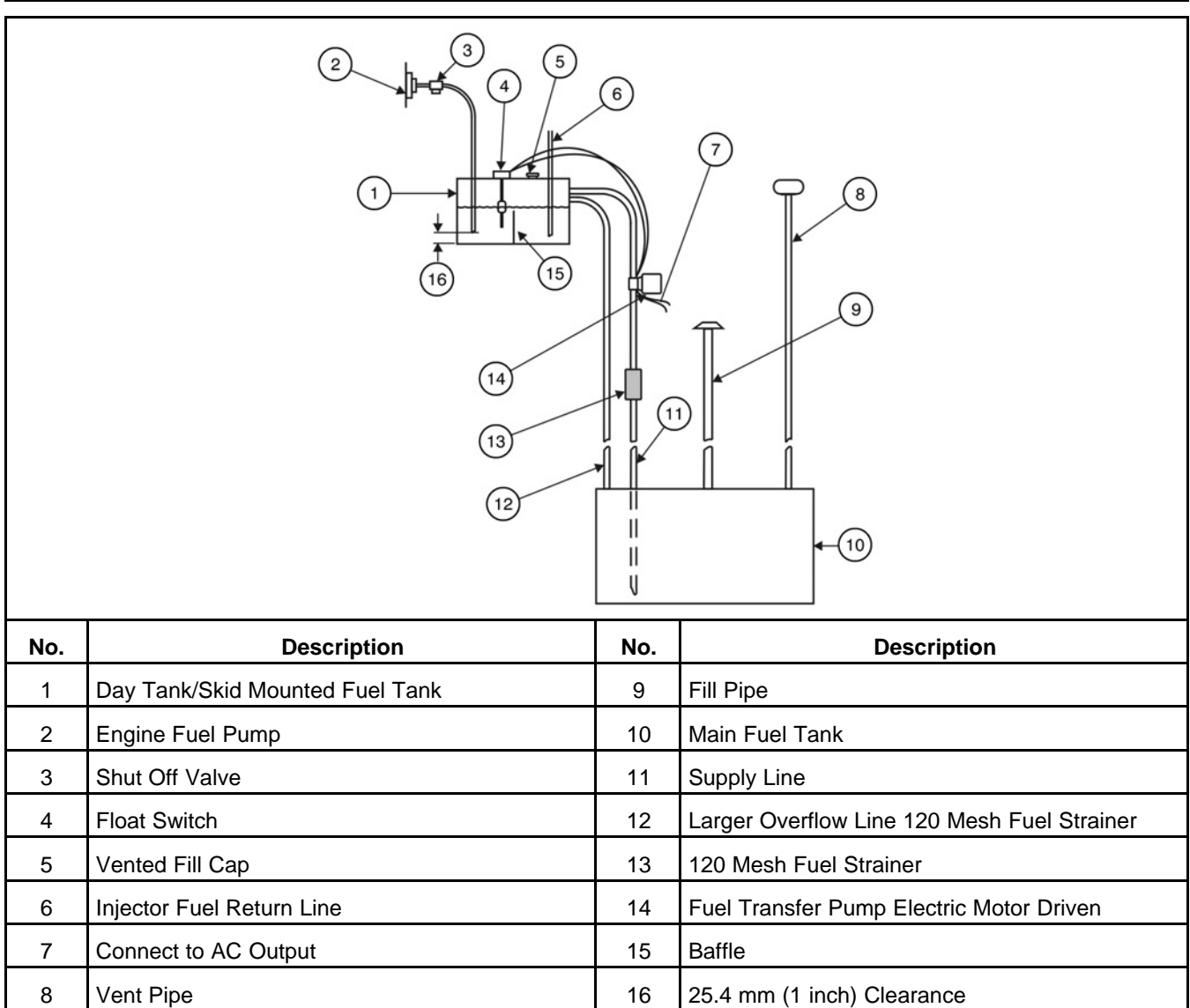

FIGURE 8. TYPICAL FUEL SUPPLY INSTALLATION

7.1.3 Engine Fuel Connections

Identification tags are attached to the fuel supply line and fuel return line connections. All models require a fuel return line from the injectors to the tank.

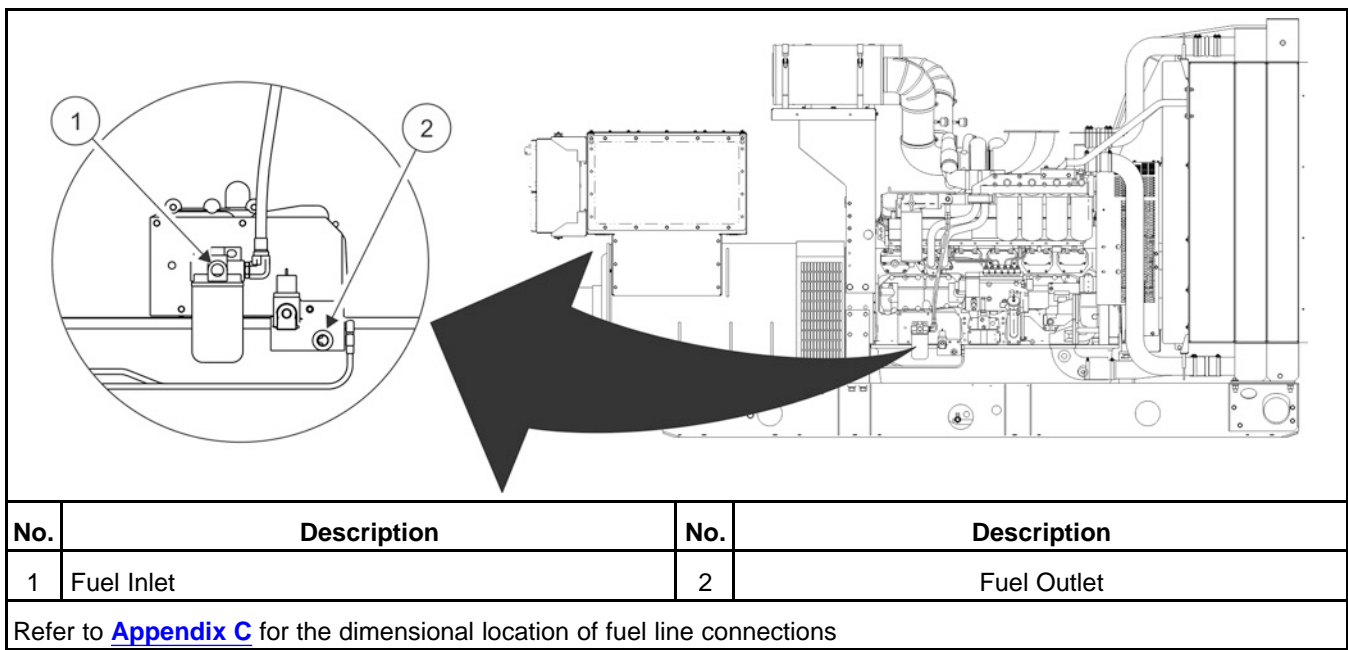

FIGURE 9. FUEL CONNECTION LOCATIONS

TABLE 7. FUEL CONNECTION GUIDELINES

	Fuel Inlet	Fuel Outlet
Connection Size	1-1/16-12UNF - 2A with 37° TIP	7/8-14UNF - 2A with 37°deg
Hose Type	Eaton 1503 or Equivalent	Eaton 1503 or Equivalent
Max Restriction	Refer to Chapter 5	

7.1.4 Supply Tank

The fuel supply tank, day tank, or other reservoir must be arranged so that the highest fuel level does not exceed the maximum height above the fuel injectors specified for the engine. The lowest level must not fall below the specified lift height of the engine fuel lift pump. In critical start applications, the lowest level should not be less than 150 mm (6 inches) above the engine fuel pump inlet to make sure there is no air in the fuel line during startup. Provisions must be made for draining or pumping out water.

For critical start applications, where generator sets are paralleled or must satisfy emergency start-time requirements, it is recommended that a fuel tank or reservoir be located such that the lowest possible fuel level is not less than 150 mm (6 in) above the fuel pump inlet. This will prevent air from accumulating in the fuel line while the generator set is in standby, eliminating the period during startup when it has to be purged.

Locate the fuel tank as close as possible to the generator set and within the restriction limitations of the fuel pump.

Install a fuel tank that has sufficient capacity to supply the generator set depending on its application:

- Continuous power
- Prime power
- Standby power

Refer to the Engine Fuel Consumption section for fuel consumption data.

If the fuel inlet restriction exceeds the defined limit due to the distance/customer-supplied plumbing between the generator set and the main fuel tank, a transfer tank (sometimes referred to as a day tank) and auxiliary pump will also be required. If an overhead main fuel tank is installed, a transfer tank and float valve will be required to prevent fuel head pressures from being placed on the fuel system components.

For additional information on the size and installation of a supply tank for the application, consult your local authorized Cummins distributor or dealer.

7.1.5 Fuel Inlet Pressure/Restriction Limit

Engine performance and fuel system durability is compromised if the fuel inlet pressure or restriction limits are not adhered to. Fuel inlet pressure or restriction must not exceed the limits stated in the model-specific generator set *Specification Sheet*.

7.1.6 Day Tank

Some generator set installations may include a fuel day tank. They are used when fuel inlet restriction limits cannot be met, or the supply tank is overhead and presents problems of high fuel head pressure for the fuel inlet and return lines.

7.1.6.1 Supply Tank Lower Than Engine

WARNING

Combustible Liquid

Spilled fuel is a fire and explosion hazard which can cause severe personal injury or death.

Provide an overflow line to the supply tank from the day tank.

NOTICE

The supply tank top must be below the day tank top to prevent siphoning from the fuel supply to the day tank.

With this installation, the day tank is installed near the generator set, below the fuel injection system and within the fuel inlet restriction limit. Install a fuel transfer pump, to pump fuel from the supply tank to the day tank. A float switch in the day tank controls operation of the auxiliary fuel pump.

Provide a return line from the engine injection system return connection to the day tank. Plumb the return line to the bottom of day tank as shown in [Figure 8 on page 43](#). Provide a day tank overflow line to the supply tank in case the float switch fails to shut off the fuel transfer pump.

7.1.6.2 Supply Tank Higher Than Engine

With this installation, the day tank is installed near the generator set, above the fuel injection system and within the fuel return restriction limit. Include an automatic fuel shutoff valve in the fuel line between the fuel supply tank and the day tank to stop fuel flow when the generator set is off.

Provide a return line from the engine injection system return connection to the day tank. Plumb the return line to the bottom of day tank as shown in [Figure 8 on page 43](#).

NOTICE

Spilled fuel can create environmental hazards. Check local requirements for containment and prevention of draining to sewer and ground water.

7.1.7 Fuel Transfer Pump

7.1.7.1 Fuel Transfer Pump Installation

⚠ WARNING
<p><i>Combustible Liquid</i></p> <p>Fuel leaks are a fire and explosion hazard which can cause severe personal injury or death. Make sure that only trained and experienced personnel install and service the generator set in accordance with applicable codes.</p>

NOTICE
<p>Do not smoke near fuel and keep flames, sparks, pilot lights, arcing switches and equipment, and other sources of ignition well away.</p>

A fuel transfer pump and control are available as an option when a sub-base or an in-skid day tank is provided. The automatic control operates the fuel pump to maintain a reservoir of fuel in the day tank.

7.1.7.1.1 Sub-Base Installation

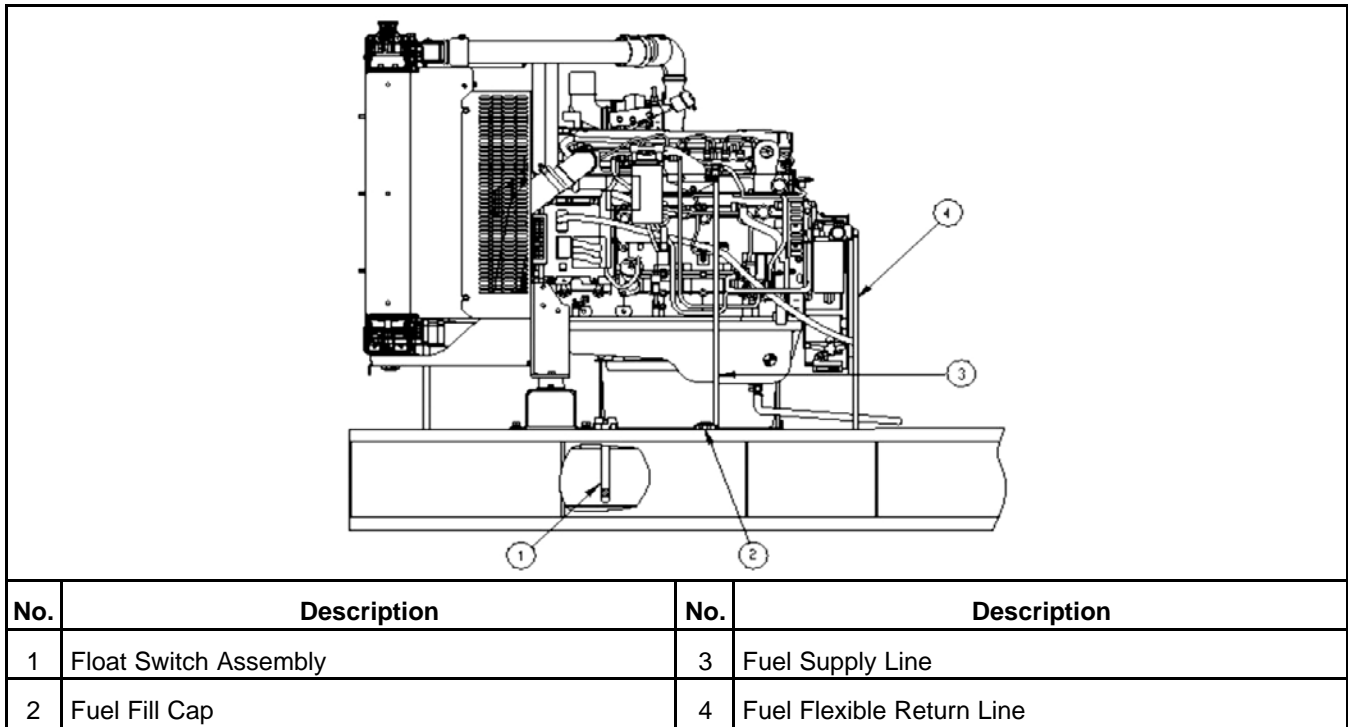

FIGURE 10. TYPICAL SUB-BASE INSTALLATION

7.1.8 Fuel Additives

NOTICE
<p>It is the responsibility of the user to ensure that the correct additives and installation of an external fuel supply is designed to meet the local climate conditions.</p>

Cummins engines are designed, developed, rated, and built to operate on commercially available diesel fuel, therefore, it is not our policy to recommend fuel additives. However in certain situations, when available fuels are of poor quality or problems exist which are peculiar to certain operations or climate conditions, additives can be used. Consult with the fuel supplier and your local distributor prior to the use of fuel additives.

7.2 Exhaust System

WARNING

Toxic Gases

Inhalation of exhaust gases can cause asphyxiation and death.

Use extreme care during installation to provide a tight exhaust system. Terminate exhaust pipes away from enclosed or sheltered areas, windows, doors, and vents. Do not use exhaust heat to warm a room, compartment, or storage area.

WARNING

Hot Surface

Hot surfaces can start a fire which can cause severe burns or death.

Use an approved thimble where exhaust pipes pass through wall or partitions.

NOTICE

Weight applied to the engine manifold can result in turbocharger damage. Support the silencer and exhaust piping so no weight or stress is applied to the engine exhaust elbow.

NOTICE

Liability for injury, death, damage, and warranty expense due to use of unapproved silencers or modifications to the exhaust system becomes the responsibility of the person installing the unapproved silencer or performing the modification. Contact your authorized distributor for approved exhaust system parts.

Pipe exhaust gases to the outside of any enclosure/room. Locate the exhaust outlets away from any air inlets to avoid gases re-entering the enclosure/room. Exhaust installations are subject to various detrimental conditions such as extreme heat, infrequent operation, and light loads. Regularly inspect the exhaust system both visually and audibly to see that the entire system remains fume tight and safe for operation.

NOTICE

Enclosed generator sets are not generally designed to be used in a building. If the generator set is to be used in a building, additional requirements must be applied.

Where an enclosed generator set is used in a building, the exhaust system should be extended to vent the exhaust gases. Use sealed joint type fittings where possible to provide a tight exhaust system. Use of slip type fittings (secured with a clamp) may allow leakage of exhaust gases into the building if not fitted correctly. Check to make sure there are no exhaust leaks.

NOTICE

Flexible pipes must be installed vertically and must be aligned fully with engine and exhaust tubes. The pipes must not have any bends or curves.

When a unit is provided with a partially installed or incomplete exhaust system, exhaust piping and chimneys shall be designed, constructed, and installed in accordance with the Standard for the Installation and Use of Stationary Combustion Engines and Gas Turbines, NFPA 37, or applicable local standards. Build according to the code requirements in effect at the installation site.

For indoor installation, the exhaust system should use sealed joint type fittings where possible to provide a tight exhaust system. Use of slip type fittings (secured with a clamp) may allow leakage of exhaust gases into the building if not fitted correctly. Check to make sure there are no exhaust leaks.

Use an approved thimble (see [Figure 15 on page 51](#)) where exhaust pipes pass through a wall or partition. Insulated wall/roof thimbles are used where exhaust pipes pass through a combustible roof or wall. This includes structures, such as wood framing or insulated steel decking, etc. Uninsulated wall/roof thimbles are used where exhaust pipes pass through a non-combustible wall or roof, such as concrete. When a unit is provided with a partially installed or incomplete exhaust system, exhaust piping and chimneys shall be designed, constructed, and installed in accordance with the Standard for the Installation and Use of Stationary Combustion Engines and Gas Turbines, NFPA 37, or applicable local standards. Build according to the code requirements in effect at the installation site.

Rain caps are available for the discharge end of vertical exhaust pipes. The rain cap clamps onto the end of the pipe and opens due to exhaust discharge force from the generator set. When the generator set is stopped, the rain cap automatically closes, protecting the exhaust system from rain, snow, etc.

Use a section of flexible exhaust pipe between the engine and remainder of exhaust system. Support the exhaust system to prevent weight from being applied to engine exhaust outlet elbow/turbocharger connection.

The exhaust system design should meet local code requirements.

Avoid sharp bends by using sweeping, long radius elbows and provide adequate support for the silencer and tailpipe. Pitch a horizontal run of exhaust pipe downward (away from engine) to allow any moisture condensation to drain away from the engine. If an exhaust pipe must be turned upward, install a condensation trap at the point where the rise begins (see [Figure 12 on page 49](#)).

Shield or insulate exhaust lines if there is danger of personal contact. Allow at least 305 mm (12 inches) of clearance if the pipes pass close to a combustible wall or partition. Before installing insulation on exhaust system components, check the exhaust system for leaks while operating the generator set under full load and correct all leaks.

Refer to T-030, *Liquid Cooled Generator Set Application Manual* for more detailed information about sizes of exhaust system pipes and fittings.

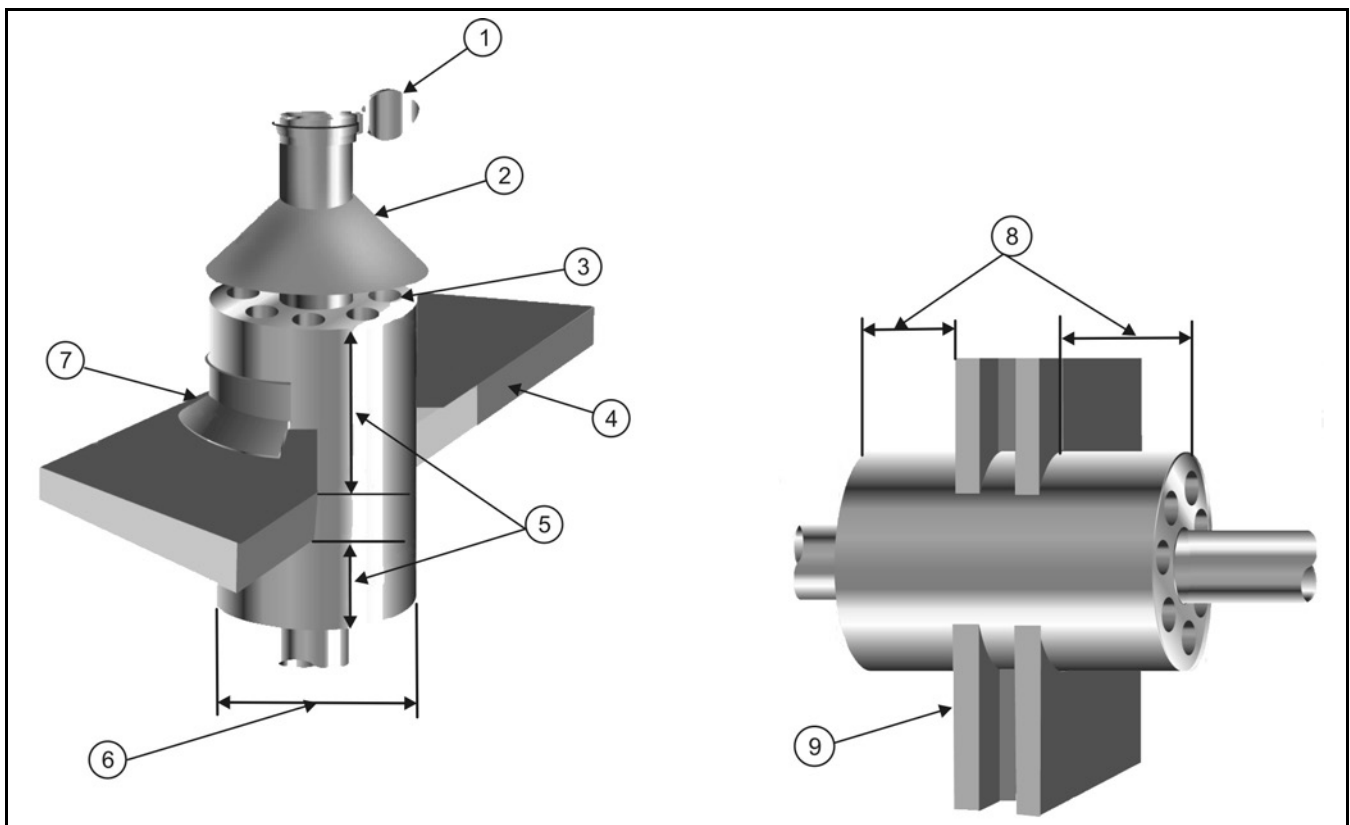

No.	Description	No.	Description
1	Rain Cap	6	Exhaust Pipe Diameter Plus 304 mm (12 Inches)
2	Drip Cap	7	Flashing
3	Holes in End of Inner Sleeve	8	230 mm (9 Inches) Minimum
4	Roof	9	Outside or Dividing Wall
5	230 mm (9 inches) Minimum		

FIGURE 11. EXHAUST THIMBLE

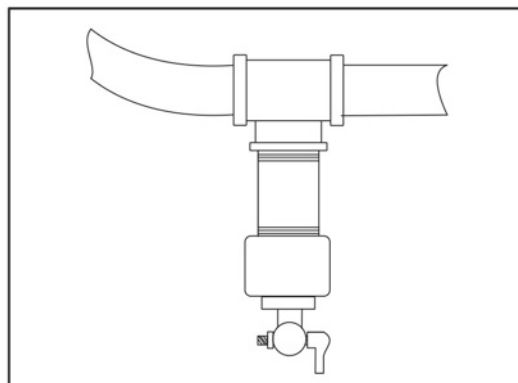

FIGURE 12. CONDENSATION TRAP

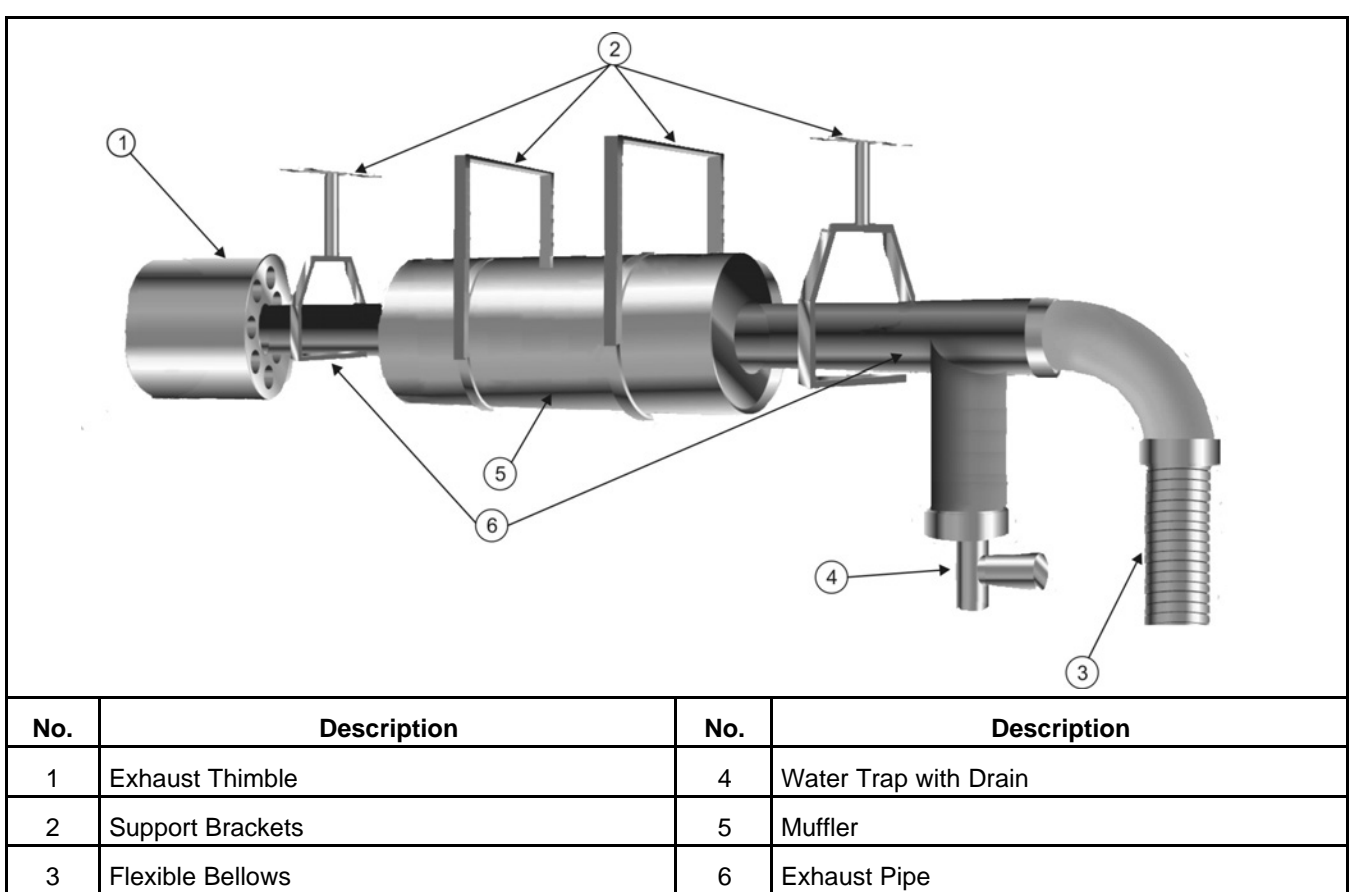

FIGURE 13. TYPICAL SUSPENDED EXHAUST SYSTEM

The bottom of the muffler is being supported by two mounting brackets with 4 M20 screws under the mounting brackets used to fix them. Two clamps on the top of the silencer fits with mounting brackets and 4 M20 screws, nuts, and gaskets. Installation torque for the screw following Q/STB 12.521.5-2000 is required.

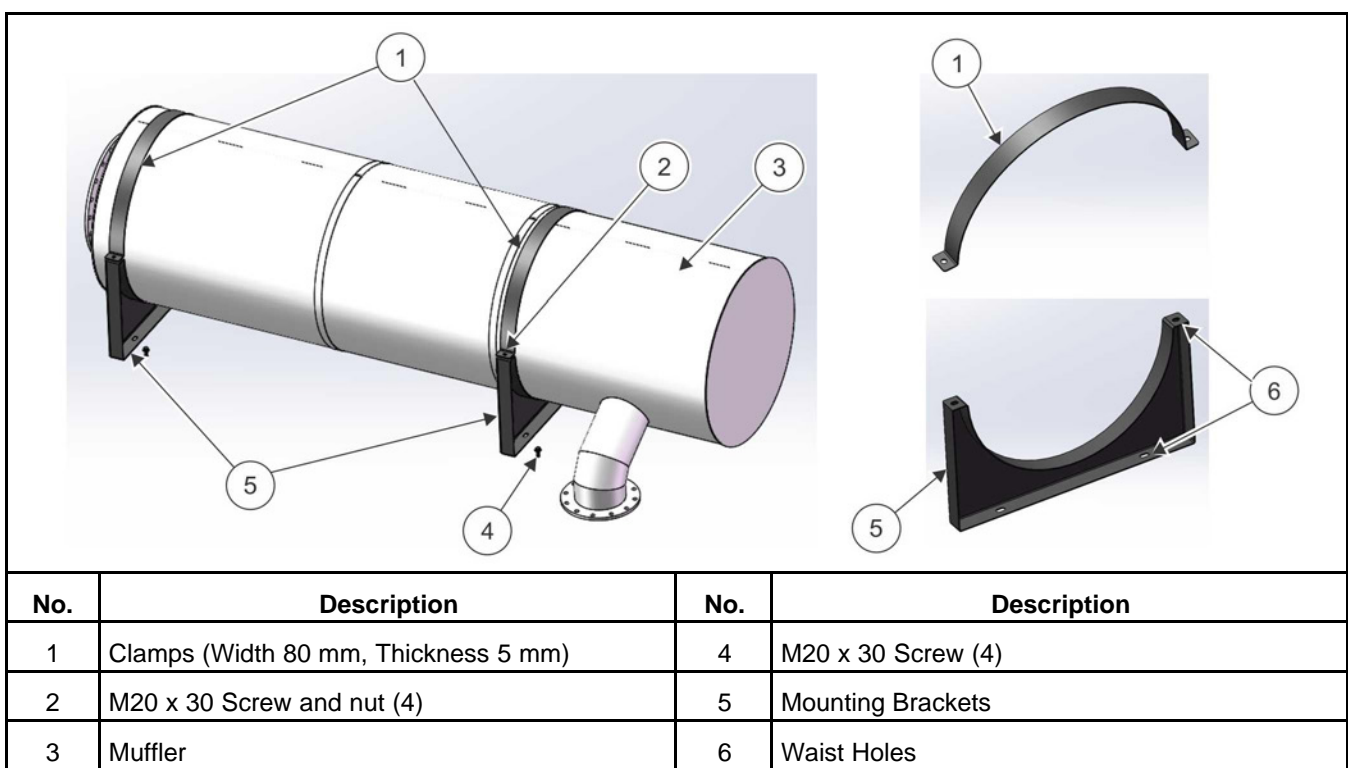

FIGURE 14. MUFFLER ASSEMBLY INSTALLATION (4 IN 1)

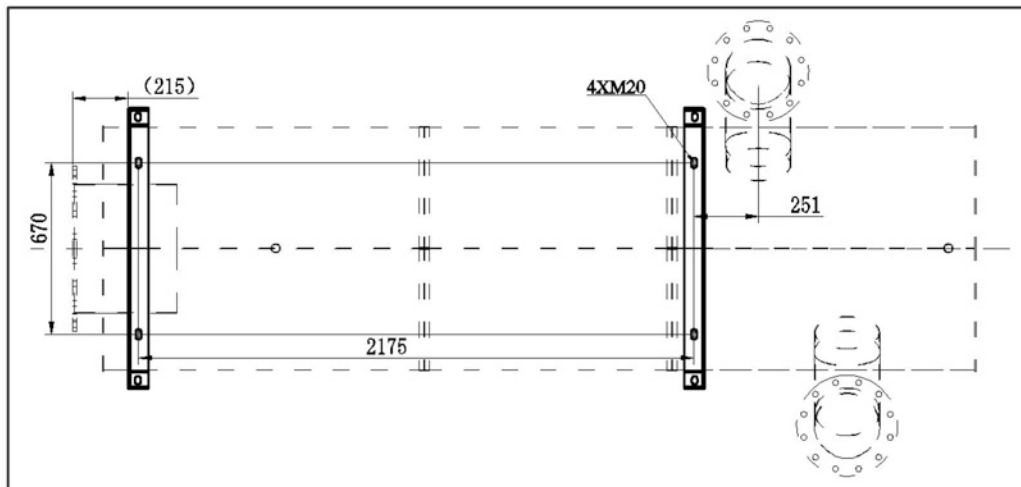

FIGURE 15. MUFFLER INSTALLATION HOLES (WITH DISTANCE FOR BRACKET INSTALLATION)

7.3 Ventilation and Cooling

⚠ WARNING

Toxic Gases

Engine and radiator cooling air may carry carbon monoxide gas, which can cause asphyxiation and death.

Pipe exhaust gas outside and away from windows, doors, or other inlets to buildings. Do not allow exhaust gas to accumulate in habitable areas.

Generator sets create considerable heat that must be removed by proper ventilation.

Generator sets in factory-mounted housings for outdoor installation are designed for proper cooling and ventilation.

Indoor installations require careful design with respect to cooling and ventilation. In an indoor installation, all radiator cooling air must be discharged to the out-of-doors. Duct adapter kits are available.

Outdoor installations normally rely on natural air circulation but indoor installations need properly sized and positioned vents for required airflow.

Transfer the stray voltage from the cooling system to the ground through the skid.

7.4 Vents and Ducts

1. For indoor installations, locate vents so incoming air passes through the immediate area of the installation before exhausting. Install the air outlet higher than the air inlet to allow for convection air movement.
2. Size the vents and ducts so they are large enough to allow the required flow rate of air.
3. Wind will restrict free airflow if it blows directly into the air outlet vent. Locate the outlet vent so the effects of wind are eliminated, or if the outlet vent cannot be located as mentioned, install a wind barrier. See [Figure 16](#).

NOTICE

The "free area" of ducts must be as large as the exposed area of the radiator. Refer to the generator set Specification Sheet for the airflow requirements and allowed airflow restriction.

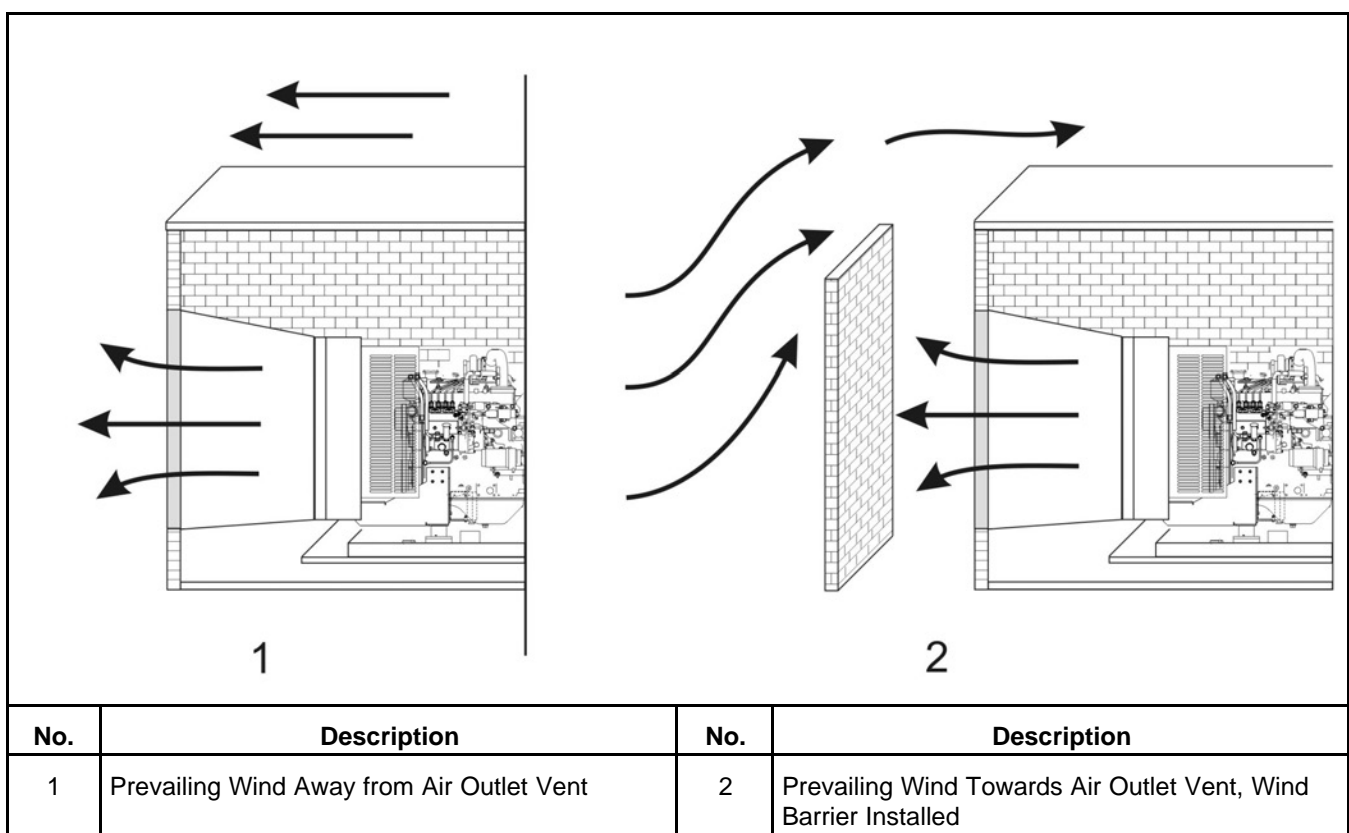

FIGURE 16. WIND BARRIER

7.5 Dampers

Dampers or louvers protect the generator set and equipment room from the outside environment. Their operation of opening and closing should be controlled by operation of the generator set.

In cold climates, the radiator exhaust air can be recirculated to modulate the ambient air temperature in the generator set room. This will help the generator set warm up faster, and help to keep fuel temperatures higher than the cloud point of the fuel. If recirculation dampers are used, they should be designed to 'fail closed', with the main exhaust dampers open, so that the generator set can continue to operate when required. Designers should be aware that the generator set room operating temperature will be very close to the outdoor temperature, and either not route water piping through the generator set room, or protect it from freezing.

7.6 Air Inlet and Outlet Openings

Louvers and screens over air inlet and outlet openings restrict air flow and vary widely in performance.

A louver assembly with narrow vanes, for example, tends to be more restrictive than one with wide vanes. The effective open area specified by the louver or screen manufacturer should be used.

Radiator set cooling air is drawn past the control end of the set by a pusher fan that blows air through the radiator. Locate the air inlet to the rear of the set. Make the inlet vent opening 1.5 times larger than the radiator area.

Locate the cooling air outlet directly in front of the radiator and as close as possible. The outlet opening must be at least as large as the radiator area. Length and shape of the air outlet duct should offer minimum restriction to airflow.

A flexible duct connector must be provided at the radiator to prevent exhaust air recirculation around the radiator, to take up generator set movement and vibration, and to prevent transmission of noise. Attach the flexible duct using screws and nuts so that the duct can be removed for maintenance purposes. Before installing the duct, remove the radiator core guard.

Enclosed generator sets are primarily designed to work in an open environment. When considering installing an enclosed generator set in an enclosed environment specific application factors must be considered (air flow, exhaust gas extraction, fuel supply and storage, etc.). For advice, contact the Application Engineering Group at Cummins Inc.

NOTICE

This installation is not done at the factory; it is done at the customer site by the distributor.

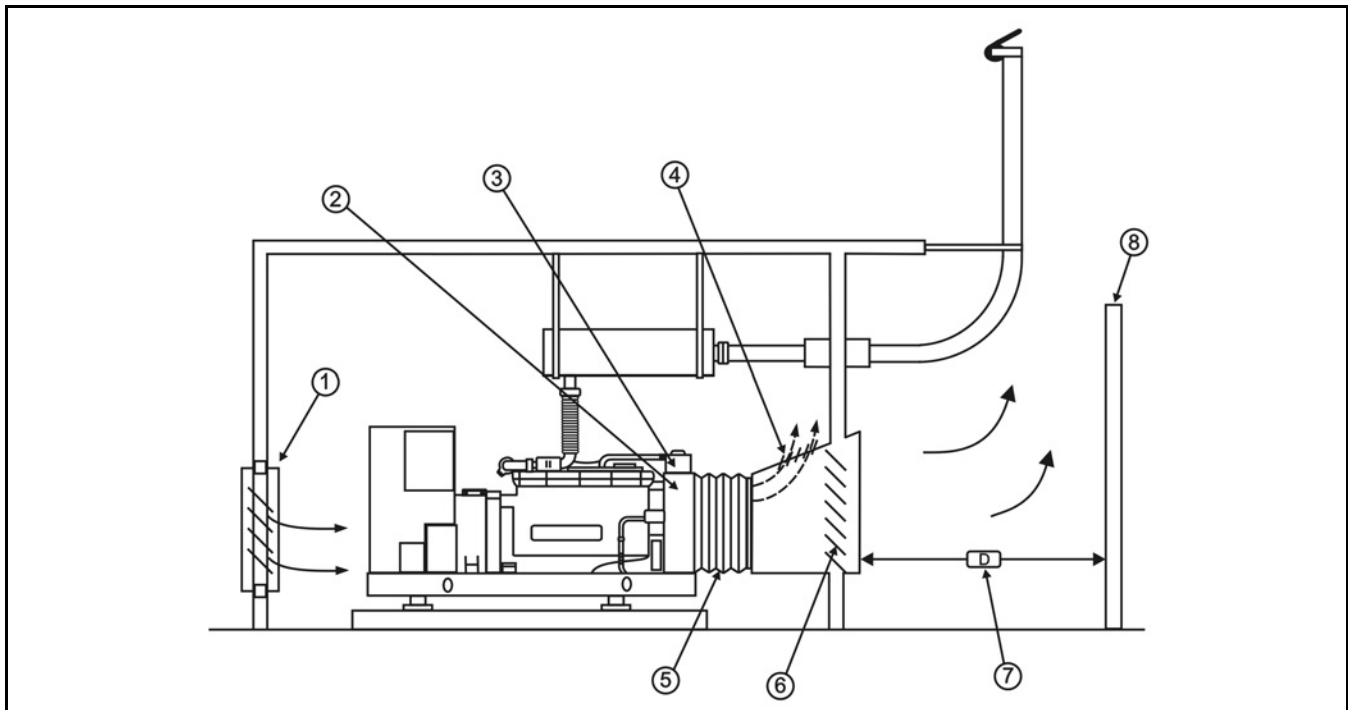

No.	Description	No.	Description
1	Cool Air Inlet Damper	5	Flexible Duct Connector
2	Engine Driven Fan	6	Hot Air Outlet Damper
3	Cooling System	7	Distance Should Not be Less Than Height of Cooling System
4	Thermostat Controlled Re-Circulating Damper	8	Wind/Noise Barrier

FIGURE 17. TYPICAL OPEN GENERATOR SET INSTALLATION

7.7 Remote Radiator Cooling

The remote radiator cooling substitutes a remote mounted radiator and an electrically driven fan in place of generator set mounted components. Removal of the radiator and the fan from the generator set reduces noise levels without forcing dependence on a continuous cooling water supply (necessary with heat exchanger cooling). The remote radiator installation must be completely protected against freezing.

Remote radiator plumbing will vary with installation. Follow recommendations given in Application Manual T-030. See product for friction head and static head limits.

NOTICE

Before filling the cooling system, make sure all hardware is tight. This includes hose clamps, cap screws, fittings, and connections. Use flexible coolant lines with heat exchanger or remote mounted radiator.

NOTICE

All customer connections must be fully supported where they interface with flexible coolant flange. The support must be located within 100 mm from the flexible flange connection.

7.7.1 Remote Radiator Installation

Installations set up for remote radiator cooling may or may not include flanges. Refer to [Appendix C on page 125](#) for outline drawings showing remote radiator installations.

A low coolant level sender and a wiring harness are supplied with the generator set. Once the low coolant level sender is installed, refer to [Appendix E on page 155](#) for information on connecting the wiring harness.

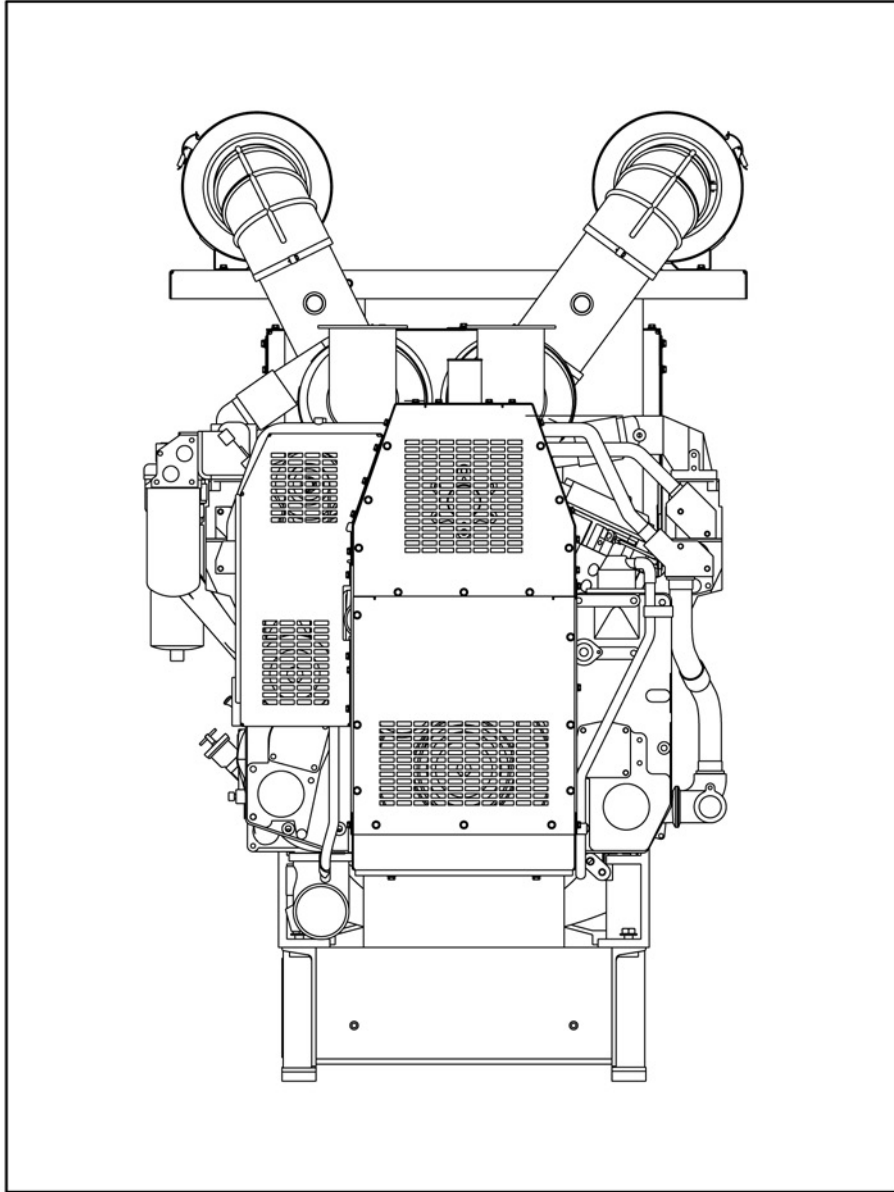

FIGURE 18. REMOTE RADIATOR COOLING COMPONENTS

7.8 Breakerless Conductor Connections

7.8.1 Overload and Short Circuit Protection of Generator

NFPA 70: National Electrical Code compliant generator sets are required to be protected from an overload. Cummins generator sets with UL Listed AmpSentry Protective Relay as a standard feature do not require a circuit breaker or other protective device for NEC compliance or UL 2200 Listing.

CEC: Each conductor between the generator terminal and the point where load receives supply of generator current must be protected by an overcurrent device in accordance with the requirement of CEC 14-100: Overcurrent Protection of Conductor.

UL label indicates to the Authority Having Jurisdiction (AHJ) that the generator set incorporates a UL Listed Protective Relay that provides overload and short circuit protection for the generator and its conductors. The generator set does not require use of a circuit breaker or other protective device for NFPA 70: National Electrical Code compliance or UL 2200 Listing.

If Amp Sentry is not being used as the primary overload device, the size of the circuit breaker **must** be rated equal to or greater than the generator set voltage with a current rating at least 100 percent (inclusive) of the rated output current of the unit and no more than 125 percent. The circuit breaker **must** be installed no more than 25 feet (7.6 m) from the generator set output terminals.

7.8.1.1 AmpSentry Labels

These are typical labels for UL compliant generator sets produced after January 2012.



FIGURE 19. POWER COMMAND 3.3 LABEL

**PowerCommand Generator Set Protective Relay with AmpSentry™
Current Monitoring and Control**

PowerCommand Protective Relay with AmpSentry current monitoring and control provides overload and overcurrent protection of generator and feeder conductors at generator terminals in accordance with the requirements of 2011 NFPA 70: National Electrical Code, Articles 240.15(A), 240.21(G), 445.12(A), 445.13 and Canadian Electrical Code, Part I, C22.1-09, Section 28-902 without the use of an additional protective device.

A disconnect for the generator set is required per 2011 NFPA 70: National Electrical Code, Articles 225.31, 225.32, and 445.18 and Canadian Electrical Code, Part I, C22.1-09, Section 28-900 unless the driving means for the generator set can be readily shutdown and the generator is not arranged to operate in parallel with another generator or source of voltage. This engine-generator includes an emergency stop switch with lockout/tagout capability that meets this requirement.

PowerCommand Protective Relay with AmpSentry current monitoring and control allows selective coordination of generator with a downstream instantaneous trip overcurrent protective device in accordance with the requirements of 2011 NFPA 70: National Electrical Code, Articles 700.27, 701.27, 708.54 and Canadian Electrical Code, Part I, C22.1-09, Section 46-206. Verification of generator set electrical system coordination must be achieved by a coordination study.

**Relais de protection de groupe électrogène PowerCommand avec
fonction de mesurage et contrôle AmpSentry™**

Le relais de protection PowerCommand avec fonction de mesurage et contrôle AmpSentry fournit une protection contre les surintensités à l'alternateur du groupe électrogène ainsi qu'aux conducteurs y étant raccordés conformément aux conditions énumérées dans le Code Canadien de l'Électricité Partie I, CSA C22.2-09 Section 28-902 et ce, sans l'usage d'appareils de protection supplémentaires.

Un sectionneur permettant de déconnecter l'alternateur du groupe électrogène est exigé par le Code Canadien de l'Électricité Partie I, CSA C22.2-09 Section 28-900 à moins que les moyens d'entraînement du groupe électrogène puisse être facilement mis à l'arrêt et que le groupe électrogène ne puisse pas fonctionner en parallèle avec un autre groupe électrogène ou une autre alimentation électrique (réseau du distributeur d'électricité). Ce groupe électrogène inclut un arrêt d'urgence avec provision de cadenassage d'étiquetage (lockout/tagout) qui rencontre cette condition.

Le relais de protection PowerCommand avec fonction de mesurage et contrôle AmpSentry permet la coordination sélective de l'alternateur de ce groupe électrogène et les appareils de protection contre les surintensités de courant instantanées et temporisées situés en aval en conformité avec le Code Canadien de l'Électricité Partie I, CSA C22.2-09 Section 46-206. La vérification de la coordination sélective doit être vérifiée par une étude de coordination.

A041T769

FIGURE 20. TYPICAL INFORMATION LABEL

PowerCommand 22, 23, 33	
DC Supply Rating:	<input type="checkbox"/> 12V <input type="checkbox"/> 24V 22A Maximum
Voltage Sensing:	347/600VAC Maximum, 50/60 Hz
Current Sensing:	<input type="checkbox"/> 1A <input type="checkbox"/> 5A
Heater Voltage (opt):	<input type="checkbox"/> 120V <input type="checkbox"/> 240V
AC Input:	<input type="checkbox"/> 210V (PMG) <input type="checkbox"/> 240V (Shunt), 50/60Hz, 4 Amps
Field Output:	240V Peak, 4 Amps
Remote Input and Sensor Circuits -	24VDC Max
Output Relay Contacts:	30VAC, 3A, Resistive
Operating Ambient:	60°C Maximum Surrounding Air (Open Type)
Digital Outputs	24V, 1A
Sensor Inputs:	5VDC
Environmental:	Type I
Optional Relays (3.3 only):	250VAC/30VDC, C300 Pilot Relay

Trip Current Setting	110% of the Generator Nameplate Rating
Percent Current Setting	Trip Time
100%	Will Not Trip
135%	90 Seconds
200%	25 Seconds
300%	9 Seconds
600%	0.6 to 0.9 Seconds to Current Limiting Mode Then 9 seconds To Shut Down

A041V083

FIGURE 21. POWER COMMAND 2.2, 2.3, AND 3.3 SPECIFIC CHECK LABEL

7.8.2 AmpSentry Protective Relay Time-Over Current Characteristic Curve

The protection provided is shown in the figure below, which shows the time-current characteristic of the supplied protection. This protection curve is specifically designed to protect the generator supplied, so adjustments to the operation points for this curve are not allowed.

NOTICE

The values shown on the current scale are shown based on the value of 1.0 being equal to the nameplate rated current of the generator set for the specific operating voltage.

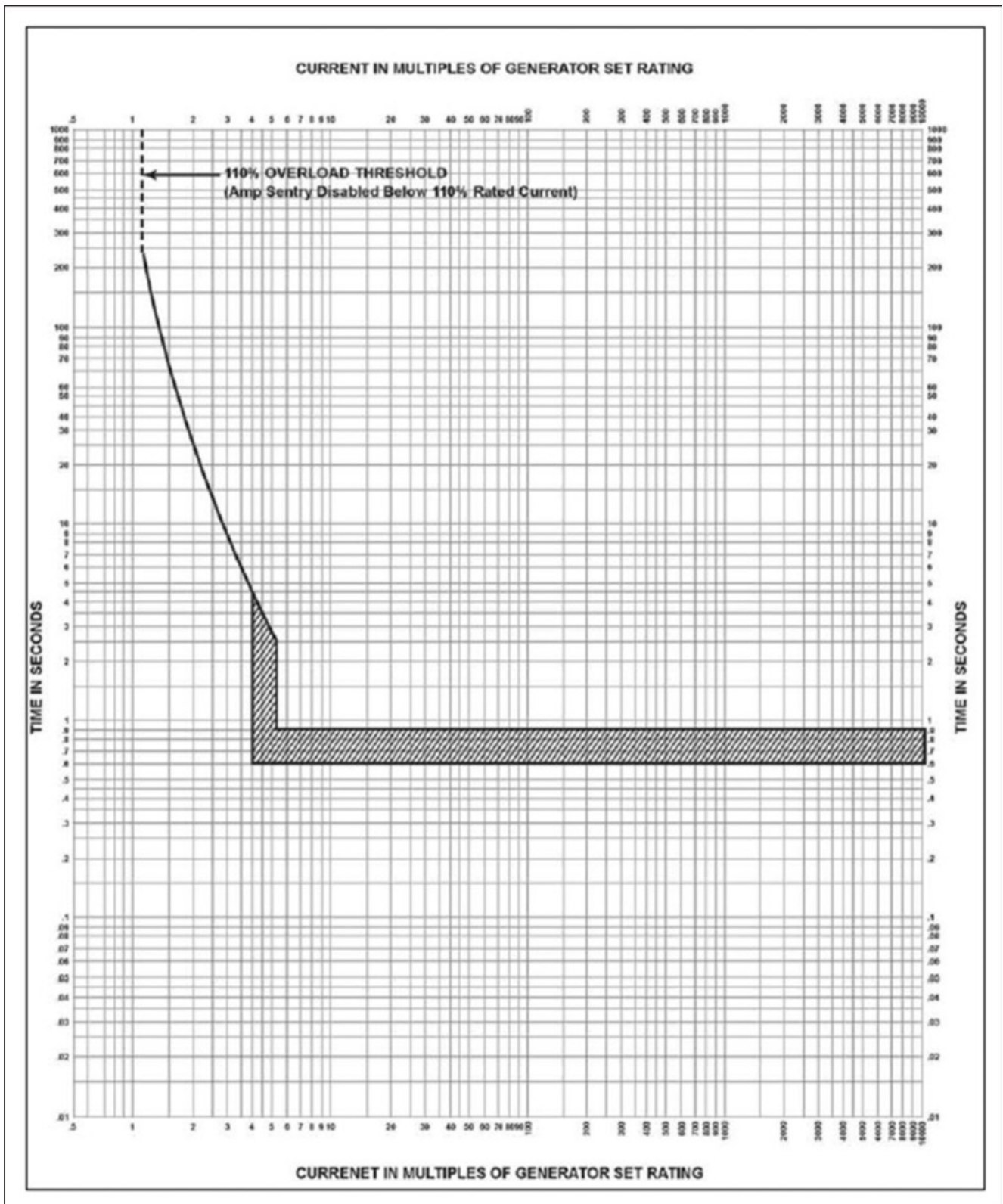

FIGURE 22. AMPSENTRY PROTECTIVE RELAY TIME OVER-CURRENT CHARACTERISTIC CURVE

7.8.3 Coordination of Protective Devices

Conduct a selective coordination (discrimination) study on the distribution system that incorporates the generator set when choosing a generator set. Visit power.cummins.com for a copy of document R-1053, or it can be found using SKM Power Tools for Windows library or from your distributor.

7.8.4 Additional AmpSentry Protective Relay Information

TABLE 8. ADDITIONAL AMPSENTRY PROTECTIVE RELAY INFORMATION FOR POWERCOMMAND 2100 CONTROL

	Voltage	No. of Phases	Frequency (Hz)	Current (Max)	Connection
Battery Supply	8-30 V		DC	22 A	TB1 (17-22)
Voltage Sense Input	347/600 V	3	50/60	10 mA	J8 (4, 7, 12, 20)
Current Sense Input		3	50/60	5 A	J7 (11, 12, 15, 16, 19, 20)
AVR Shunt Supply	240 V	1	50/60	100 mA	J8 (21-23)
AVR PMG Supply	210 V	1	50/60	100 mA	
AVR Output (Continuous)	300 V (Peak)	1	PWM	4 A	J8 (5,13)
AVR Output (Max/10 seconds)	300 V (Peak)	1	PWM	6 A	
Run Relay Output	30 V		DC	8 A; 1.44 A Pilot Duty	TB1 (17-22)
Customer Relay Output	30 V		DC	5 A	TB1 (8-15)
	250 V	1	AC	5 A; C300 Pilot Duty	
Indicator Supply	5 V		DC	50 mA	J2
Engine Sensors	5 V		DC	3 mA	J7 (13, 17, 21, 22, 25, 26, 29-35)
Governor Drive	5-30 V		DC	100 mA	J7 (14, 24, 28, 36)
Power Out	8-30 V		DC	100 mA	J7 (1-8, 18)
Solenoid Driver Signal	5-30 V		DC	100 mA	J7 (9, 10, 23, 27)
Switch Input	8-30 V		DC	1 mA	J1
Membrane Switch Input	5 V		DC	1 mA	J3
Customer Inputs	8-30 V		DC	1 mA	TB1 (1-6)

	Voltage	No. of Phases	Frequency (Hz)	Current (Max)	Connection
Power Transfer Status	5-30 V		DC	1 mA	TB2 (5)
Power Transfer Signal Supply	5-30 V		DC	100 mA	TB2 (3, 4, 6)
Interface	5 V		DC	1 mA	J50, J51, J4, J6
Communication	RS485				TB2 (1, 2)
	RS232				J9 (1-5, 9)
	CAN (Optional)				J10 (1-5)
Trip Current	110% generator nameplate Full Load Amperage				
Percentage of Trip Current	100		300		600
Trip Times	500 seconds		10 seconds		1 second
Temperature	70 °C Maximum Surrounding Air Ambient				

8 DC Control Wiring

⚠ WARNING

Electric Shock Hazard

Voltages and currents present an electrical shock hazard that can cause severe burns or death. Avoid contact with the voltage sense and bus sense leads; voltages of up to 600 VAC may still be present. These voltages could be live even when the generator set is switched off.

⚠ WARNING

Electric Shock Hazard

Voltages and currents present an electrical shock hazard that can cause severe burns or death. Make sure all power is off before performing control wire installation.

⚠ WARNING

Electric Shock Hazard

Voltages and currents present an electrical shock hazard that can cause severe burns or death. To prevent accidental electrocution, stand on a clean dry wooden platform or clean rubber insulating mat, make sure your clothing and shoes are dry, remove all jewelry, and use tools with insulated handles.

The generator set control box contains connection points for remote control and monitor options.

NOTICE

Always run control circuit wiring in a separate metal conduit from the AC power cables to avoid inducing currents that could cause problems within the control.

Use cable ties to keep control wiring away from sharp edges and AC power cables within the control housing.

NOTICE

Stranded copper wire must be used for all customer connections to the control panel. Solid copper wire may break due to the generator set vibration.

Use flexible conduit for all wiring connections to the generator set.

8.1 Guidelines for Customer Connections to the Control System

- Torque terminals to 0.5 Nm (4.4 in-lb)
- Wire type: Use 60 C rated minimum copper wire
- Terminal screws (if fitted) are slotted 0.6 mm
- Use flat bladed screwdriver with 2.5 mm blade

- Strip wire length to 6.0 mm (0.236 in) for screw type terminals and 10 mm (0.75 in) for push type terminals

8.1.1 Digital Connections

Connection points, other than relayed outputs and network are considered digital connections. The type/gauge wire to use for these connections are:

- Less than 305 m (1000 ft), use 0.5 mm² (20 gauge) stranded copper wire.
- 305 m to 610 m (1000 ft to 2000 ft), use 0.75 mm² (18 gauge) stranded copper wire.

8.1.2 Relay Connections

Due to the wide variety of devices that can be attached to the relay outputs, the electrical contractor must determine the gauge of the stranded copper wire that is used.

8.2 PowerCommand 3.3 Customer Connections

Refer Wiring Diagrams drawing.

8.2.1 Configurable Outputs

Each output has normally-open contacts. The contacts can be used to control small devices, indicator lamps, or relays.

The contacts are programmed to energize by entering a code number for the desired event.

NOTICE

Using the InPower service tool or accessing the Setup submenus is required to modify the customer outputs. Contact an authorized distributor for assistance.

8.2.1.1 Contact Ratings for Configurable Outputs

TABLE 9. CONTACT RATINGS FOR CONFIGURABLE OUTPUTS

Description	Value
Maximum Voltage	30 VDC
Maximum Current	3.5 Amps

8.2.2 Remote Start

⚠ WARNING

Automated Machinery

Accidental or remote starting of the generator set can cause severe personal injury or death.

Make sure that the generator set cannot be started accidentally or remotely before starting work on the generator.

NOTICE

Remote start terminals should only be used for a remote application. Remote start terminals are not to be shorted if the remote start function is not intended to be used.

When the control is in Auto/Remote mode, grounding this input initiates the engine cranking and start sequence. This circuit must be opened to permit resetting a shutdown condition with the Reset input. (The remote stop is actually the removal of the remote start signal to the control.)

8.2.3 Configurable Inputs

Grounding any one of these inputs activates the corresponding warning or shutdown sequence.

External sensing equipment must be connected to the designated digital input.

The nature of the fault is an optional customer selection. Example inputs: Low Coolant Level, Low Fuel Level, Ground Fault, etc.

NOTICE

The InPower service tool or access to the Setup submenus is required to modify the customer fault inputs. Contact your authorized distributor for assistance.

8.2.4 Remote Emergency Stop

Opening this input causes an immediate shutdown. Emergency stop must be reset at the remote panel, then at the front panel.

8.3 Customer Relays

8.3.1 Location of Customer Relays

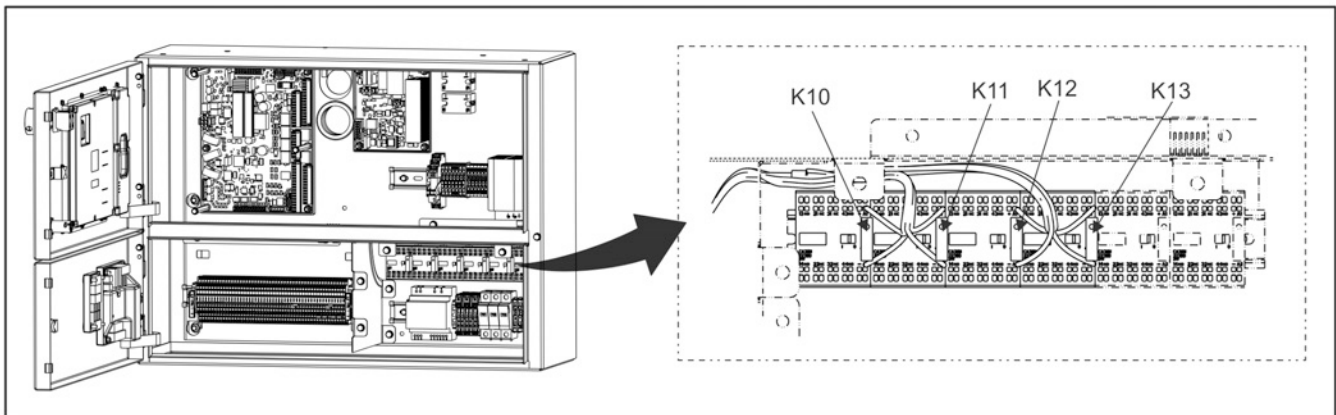

FIGURE 23. LOCATION OF CUSTOMER RELAYS

8.3.1.1 Configurable Outputs

This relay is connected to the corresponding configurable output on the control. If the configurable output is active, the relay is active. If the configurable output is inactive, the relay is inactive.

This relay allows the configurable output to control larger devices, and it isolates the control from these devices.

8.3.1.2 Contact Specifications

The contacts are rated at 10 A at 600 VAC.

8.3.1.3 Schematic

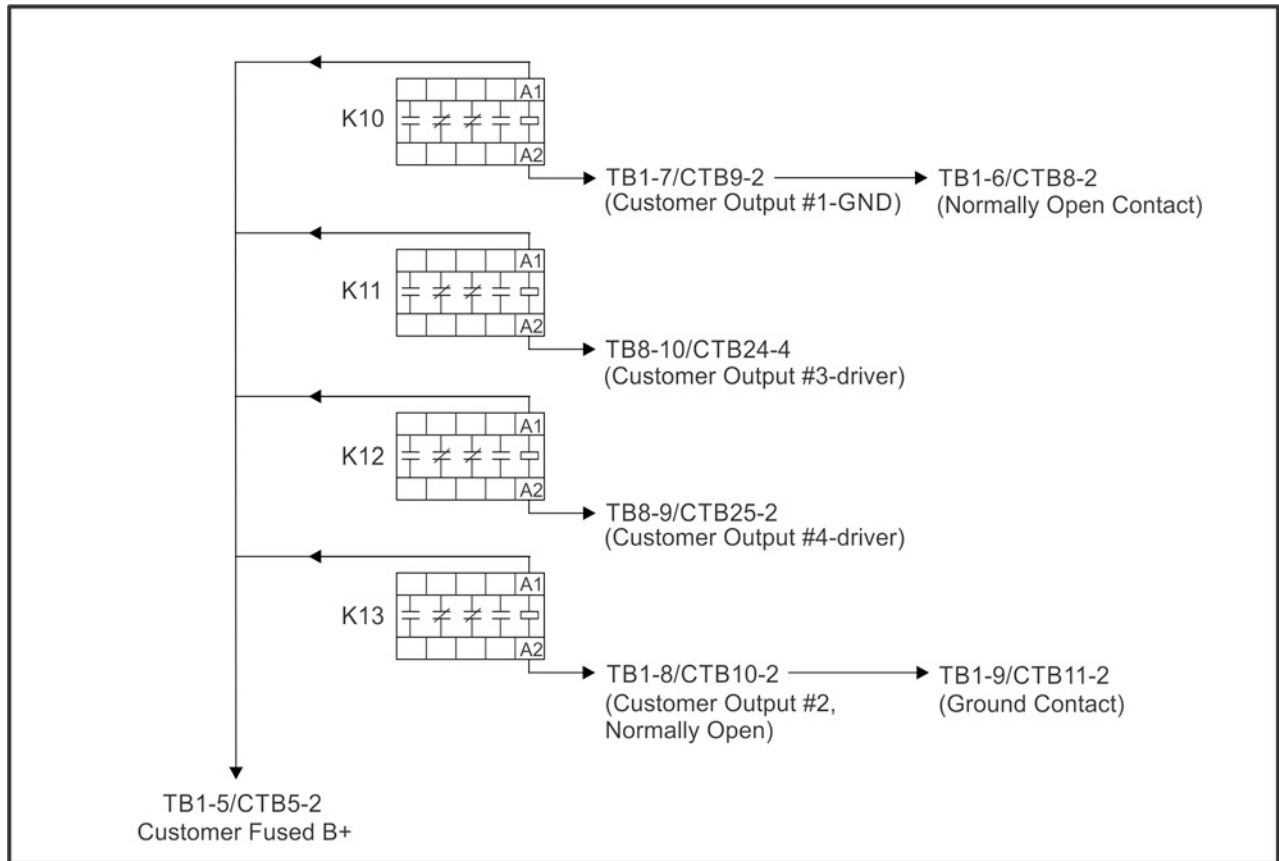

FIGURE 24. SCHEMATIC

9 AC Electrical Connections

WARNING

Arc Flash and Shock Hazard

Voltages and currents present an electrical shock hazard that can cause severe burns or death. Make sure that only service personnel who are trained and experienced perform electrical and mechanical component installations. The AC sensing harness and other cabling will become energized when the generator set is in operation.

WARNING

Hazardous Voltage

Contact with high voltages can cause severe electrical shock, burns, or death. Make sure that only personnel who are trained and qualified to work on this equipment are allowed to operate the generator set and perform maintenance on it.

WARNING

Automated Machinery

Accidental or remote starting of the generator set can cause severe personal injury or death. Isolate all auxiliary supplies and use an insulated wrench to disconnect the starting battery cables (negative [-] first).

WARNING

Combustible Gases

Ignition of battery gases is a fire and explosion hazard which can cause severe personal injury or death. Do not smoke, or switch the trouble light ON or OFF near a battery. Touch a grounded metal surface first before touching batteries to discharge static electricity. Stop the generator set and disconnect the battery charger before disconnecting battery cables. Using an insulated wrench, disconnect the negative (-) cable first and reconnect it last.

WARNING

Electric Shock Hazard

Voltages and currents present an electrical shock hazard that can cause severe burns or death. Avoid contact with the voltage sense and bus sense leads; voltages of up to 600 VAC may still be present. These voltages could be live even when the generator set is switched off.

This section provides the procedure that is used to connect the AC electrical system of the generator set.

Before making any AC electrical connections, make certain the generator set cannot be accidentally started. Make sure the Operator Panel is in OFF mode. Turn off or remove AC power from the battery charger and then remove the negative (-) battery cable from the set starting battery using an insulated wrench.

If the generator set is being installed in an application where it may parallel with other generators or utility sources, the generator set control system may be energized from an external source. Lock out tag out any external source that can provide AC power to the generator set.

NOTICE

Ventilate the battery area before working on or near battery. Wear goggles. Stop the generator set and disconnect the battery charger before disconnecting battery cables. Disconnect negative (-) cable first and reconnect last using an insulated wrench.

Connecting the generator set AC electrical system involves:

- Installation of transfer switch
- Generator output voltage selection
- Load cable connection
- Standard and optional AC equipment connections (e.g., control box heater, coolant heater, etc.).

For all output connections, including when field connection is made at the alternator terminations, installation should be completed with conductors of appropriate size, type, and rating specified in local codes (or UL). For UL compliant installations, use conductor size, X AWG, 75 °C or 90 °C copper wire, 600V. Where X AWG is the conductor size specified by the local electrical code for 75 °C at the rated output current for the generator set. Use copper conductors only. For non-UL compliant installations, use cable sizes, composition, and rating per local codes. Strain relief, bending space, raceway, and other installation features should be completed in compliance with local code.

Local regulations often require that wiring connections be made by a licensed electrician, and that the installation be inspected and approved before operation. All connections, wire sizes, materials used, etc. must conform to the requirements of electrical codes in effect at the installation site.

Before starting the generator set, check to make sure that all electrical connections are secure, and that all wiring is complete. Replace and secure any access panels that have been removed during installation. Check that the load cables from the generator set are properly connected.

NOTICE

Backfeed to a utility system can cause electrocution or property damage. Do not connect to any building electrical system except through an approved device and after the building main switch is opened.

9.1 AC Distribution Panel Connections

NOTICE

Make sure that all circuit breakers are in the OFF position before applying power to the AC distribution panel. Other options may require additional installation before connecting to power.

9.1.1 AC Distribution Panel

⚠ WARNING***Electric Shock Hazard***

Voltages and currents present an electrical shock hazard that can cause severe burns or death. Receptacles J1 through J4 are GFCI protected and must not be used by service personnel as a power source for tools or lighting.

NOTICE

Make sure that all circuit breakers are in the OFF position before applying power to the AC distribution panel. Other options may require additional installation before connecting to power.

NOTICE

When the generator set contains the fuel transfer pump option, power to the AC distribution panel must be fed from a transfer switch and step-down transformer to maintain 120V power to the pump when utility power is interrupted. If the transfer pump option is not installed, power to the AC distribution panel can be fed from a non-emergency source. (Other optional features connected to the AC distribution panel are not needed for generator set operation.)

The AC distribution panel provides a centralized power source (120/220 VAC) for all optional enclosure features.

All connections to the AC distribution panel must comply with the National Electric Code and all applicable local codes and standards using 60 or 75 °C (140 or 167 °F) conductors.

The AC distribution panel is powered with a 150 A, 120/240 VAC, single phase feeder. The 2 line conductors connect into the 150 A main breaker that is listed for #4 to 2/0 conductors, AL or CU when torqued to 5.6 Nm (50 in-lbs).

The neutral conductor connects into the neutral bus which is listed for #5 to 300KCMIL conductors, AL or CU when torqued to 28.4 Nm (21 ft-lbs).

The grounding conductor, if used, connects into the ground bar which is listed for #1 to 2/0 conductors, AL or CU when torqued to 23 Nm (17 ft-lbs).

The GFCI receptacle is a 120 VAC/20 A ground fault protected outlet that is for use by service personnel. It also supplies power to the external receptacle.

Receptacles J1 through J4 are for internal use only (not GFCI protected). They are 120 VAC/20 A outlets for optional enclosure features.

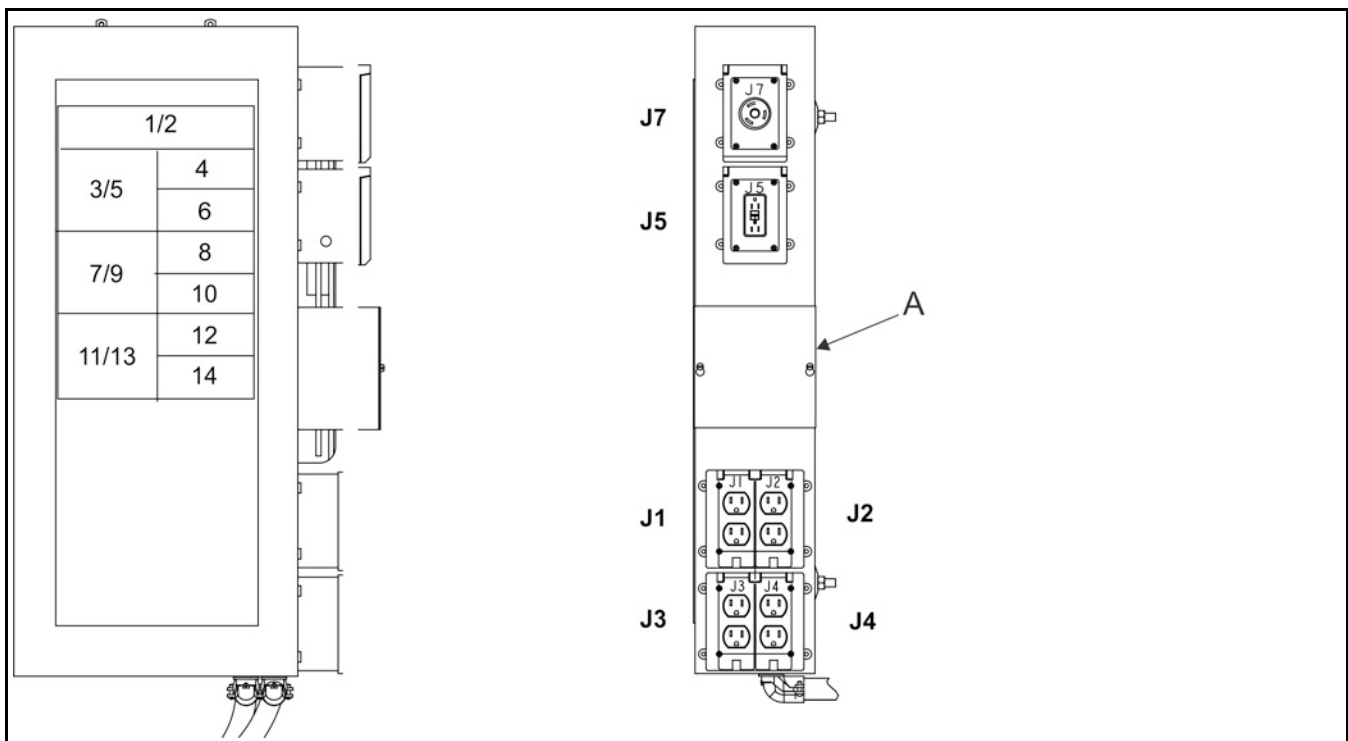

No.	Description	No.	Description
	CIRCUIT BREAKERS		120 VAC RECEPTACLES FOR OPTIONAL FEATURES
1/2	150A Main	J1	Engine Oil Heater
3/5	40A Coolant Heaters	J2	Battery Heater
7/9	40A Coolant Heaters	J3	Alternator/Control Cabinet Heaters
11/13	40A Enclosure Heater	J4	Battery Charger/Transfer Pump Controller
4	20A J7 Receptacle	J5	GFCI Service Receptacle
6	20A J5/J7 Receptacles	J6	Optional External Service Receptacle (Not Shown)
8	20A Inlet/Outlet Louvers	J7	Enclosure Lights Receptacle
10	20A J1/J2 Receptacles		
12	20A J3/J4 Receptacles		
14	Spare		

FIGURE 25. AC DISTRIBUTION PANEL

9.2 Transfer Switch

A transfer switch must be used for switching the load from the normal power source to the generator set (see [Figure 26](#)). Follow the installation instructions provided with the transfer switch when connecting the load and control wiring.

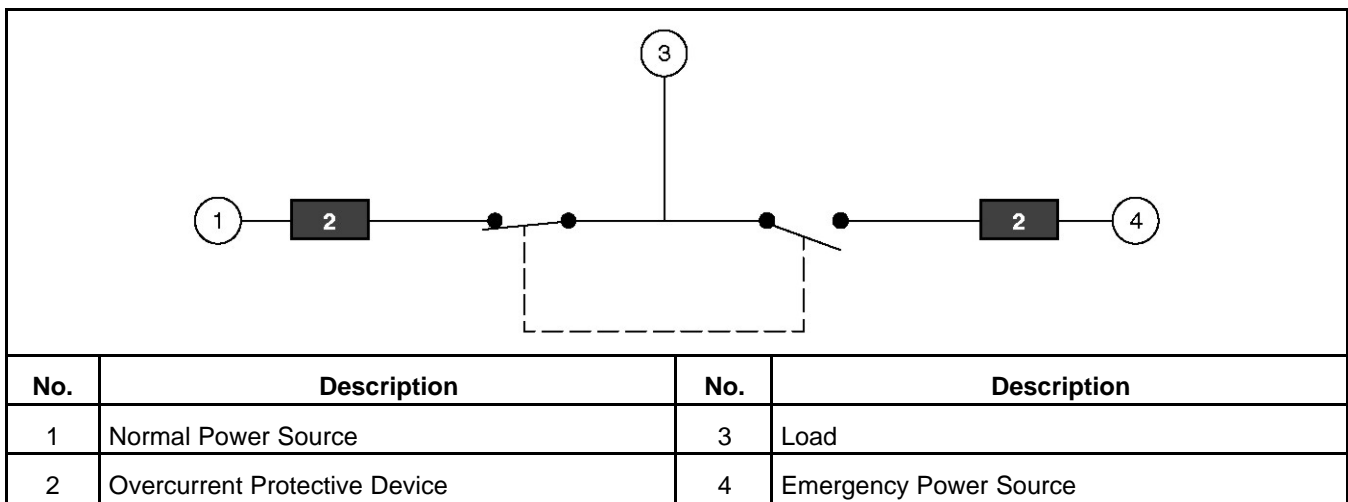

FIGURE 26. TYPICAL LOAD TRANSFER FUNCTION

9.3 Alternator Voltage Connections

These alternators can be configured to the nameplate voltages as shown on the Reconnection Diagram decal, attached to the backside of the control box cover. Many of the voltages listed will require reconfiguration of the alternator output leads on the connection terminal block. This reconfiguration must only be done by service personnel that are trained and experienced to perform electrical installation. The generator set was adjusted to produce a specified voltage during production verification testing prior to shipment. The installer must always check the stator lead terminal block connections and perform any necessary reconnect to obtain the voltage required.

Some generator sets are capable of producing a wide range of voltages and connection configurations; others have specific limited capabilities. Refer to wiring diagram and generator voltages (from the nameplate) when reviewing the voltage connection information and use the wiring diagram supplied with your generator set when actually performing load connections.

NOTICE

Reconfiguring generator sets to higher voltages can exceed the voltage capability of the specific generator windings and damage the generator and also decrease line current, rendering line circuit breakers too large. Consult with your authorized distributor before performing reconnection for a different voltage.

NOTICE

Reconfiguring generator sets to lower voltages can reduce generator set ratings, and also increase line current, rendering line circuit breakers too small. Consult with your authorized distributor before performing reconnection for a different voltage.

9.4 Load Connections

NOTICE

Flexible conduit and stranded conductors must be used for connections to take up movement of the generator set.

All loads are connected to the alternator by bolting stranded load wires to the appropriate terminals on the alternator reconnection terminal block or circuit breaker lugs. The terminals are marked U, V, W, and N to indicate the line and neutral connections. (Reference: U, V, and W correspond with L1, L2 and L3; and N with L0 respectively). See [Appendix C on page 125](#) for details about the following:

- Load connections
- Conduit
- Cable Size

9.4.1 Generator Set Load Cable Installation

To ensure optimum performance of the generator set, load cables passing through cable gland plates must be adequately protected and secured.

9.4.2 Cabling through Non-Ferrous Gland Plates

Single core load cables must be secured using non-ferrous cable glands.

9.4.3 Cabling through Ferrous Gland Plates

Single core load cables must pass through the same hole, or slotted cable grommet holes as illustrated (see [Figure 27](#)). Cable glands must be made from non-ferrous material.

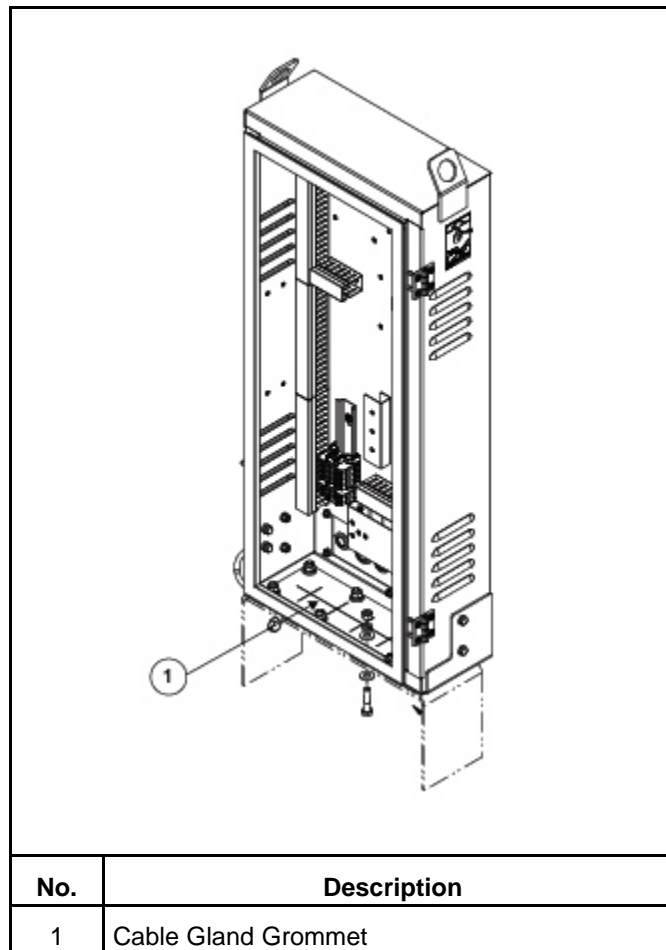

FIGURE 27. FERROUS GLAND PLATES

9.4.4 Distribution Cables

Single core power distribution cables should be grouped in a trefoil formation as illustrated (See [Figure 28](#)). (Trefoil grouping provides optimum cable loading and reduces electrical emissions). To minimize cable temperature rise and reduce cable de-rate factors, cable groups where possible, should be spaced to provide ventilation. Cable groups must be secured with non-ferrous material.

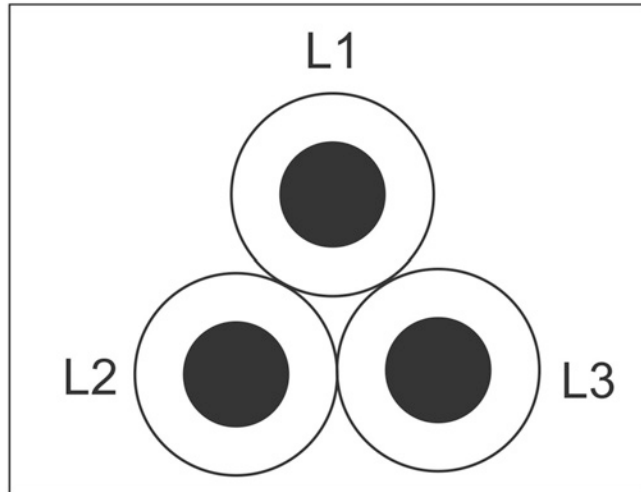

FIGURE 28. TREFOIL FORMATION

9.5 Installation of s-CAN Network Cable

The s-CAN cable connects the TB3 of the generator set MLD controller with up to 15 other generator set MLD controllers to form a closed s-CAN Network.

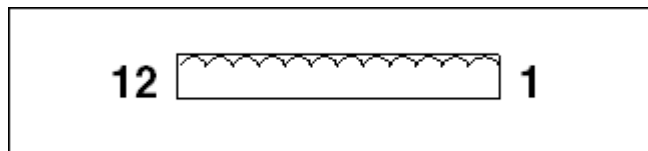

FIGURE 29. TB3 PINS

TABLE 10. TB3 PIN ASSIGNMENTS: CUSTOMER INPUT/OUTPUT CONNECTIONS

Customer Terminal Block	PCC3300 Pin	Description	Function/Connects to:
CTB26-2	TB3-1	Ground	s-CAN shield connection point or use as a signal return for switch inputs
CTB27-2	TB3-2	s-CAN Isolated Ground	s-CAN network ground only, Do not connect to chassis/Battery Ground Connect to TB3-2 of other PCC3300 controls on the s-CAN Network PCC 3300 with MLD ONLY
CTB28-2	TB3-3	s-CAN CAN L	s-CAN data line for control-to-control communications Connect to TB3-3 of other PCC3300 controls on the s-CAN Network PCC 3300 with MLD ONLY

Customer Terminal Block	PCC3300 Pin	Description	Function/Connects to:
CTB29-2	TB3-4	s-CAN CAN H	s-CAN data line for control-to-control communications Connect to TB3-4 of other PCC3300 controls on the s-CAN Network PCC 3300 with MLD ONLY

TB3-2, TB3-3, and TB3-4 s-CAN Network Connections (PC 3.3 MLD ONLY)

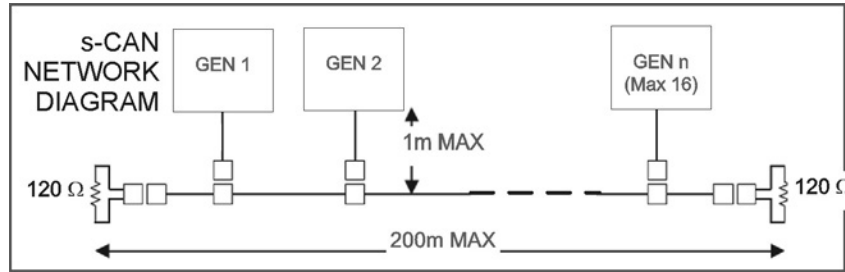

FIGURE 30. S-CAN NETWORK DIAGRAM

s-CAN cable requirements: Twisted pair (shielded) cable meets SAE J1939-11 standards, 200 m maximum network length.

NOTICE

Recommended cable type: Belden 3106A or equivalent.

To prevent ground loops shield/drain wire are to be connected to TB3-1 at only one end of a s-CAN network (bus) cable/segment. Shield continuity must be maintained over entire length of cable/segment.

NOTICE

Recommended shield connection method [Figure 31](#)

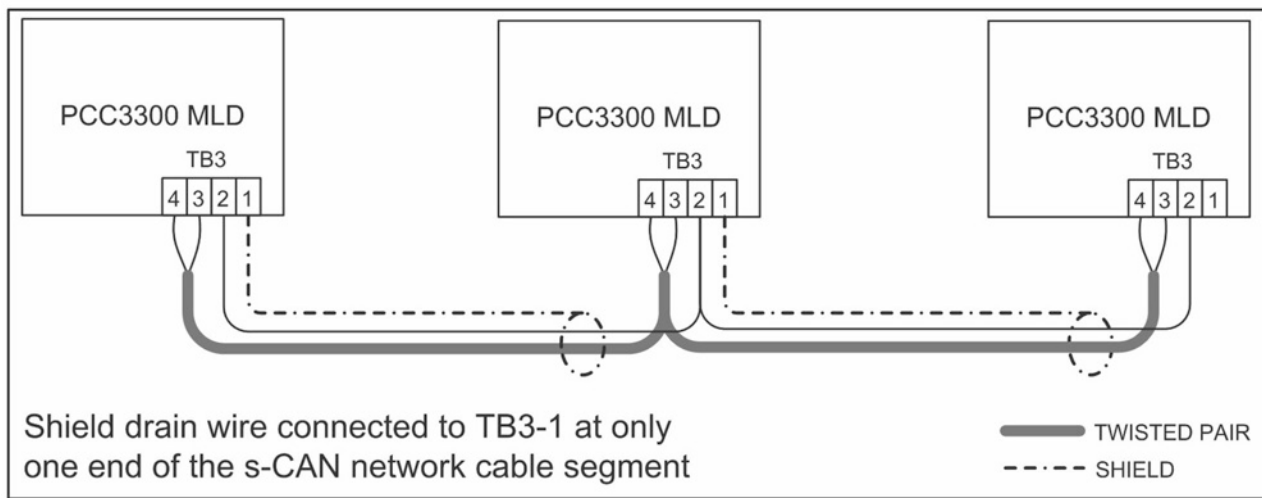

FIGURE 31. SHIELD CONNECTIONS ON MLD S-CAN NETWORK

9.6 Load Balancing

When connecting loads to the generator set, balance the loads so that the current flow from each line terminal (L1, L2, and L3) is about the same. This is especially important if both single phase and three phase loads are connected. Any combination of single phase and three phase loading can be used as long as each line current is about the same, within 10 percent of median value and no line current exceeds the name plate rating of the generator. Check the current flow from each line after connections by observing the Operator Panel ammeter.

9.7 Fuel Transfer Pump Installation

WARNING

Combustible Liquid

Fuel leaks are a fire and explosion hazard which can cause severe personal injury or death.

Make sure that only trained and experienced personnel install and service the generator set in accordance with applicable codes.

NOTICE

Do not smoke near fuel and keep flames, sparks, pilot lights, arcing switches and equipment, and other sources of ignition well away.

A fuel transfer pump and control are available as an option when a sub-base or an in-skid day tank is provided. The automatic control operates the fuel pump to maintain a reservoir of fuel in the day tank.

9.7.1 Fuel Transfer Pump Control AC Connections

See the wiring diagrams provided with your generator set when making connections at the fuel pump control.

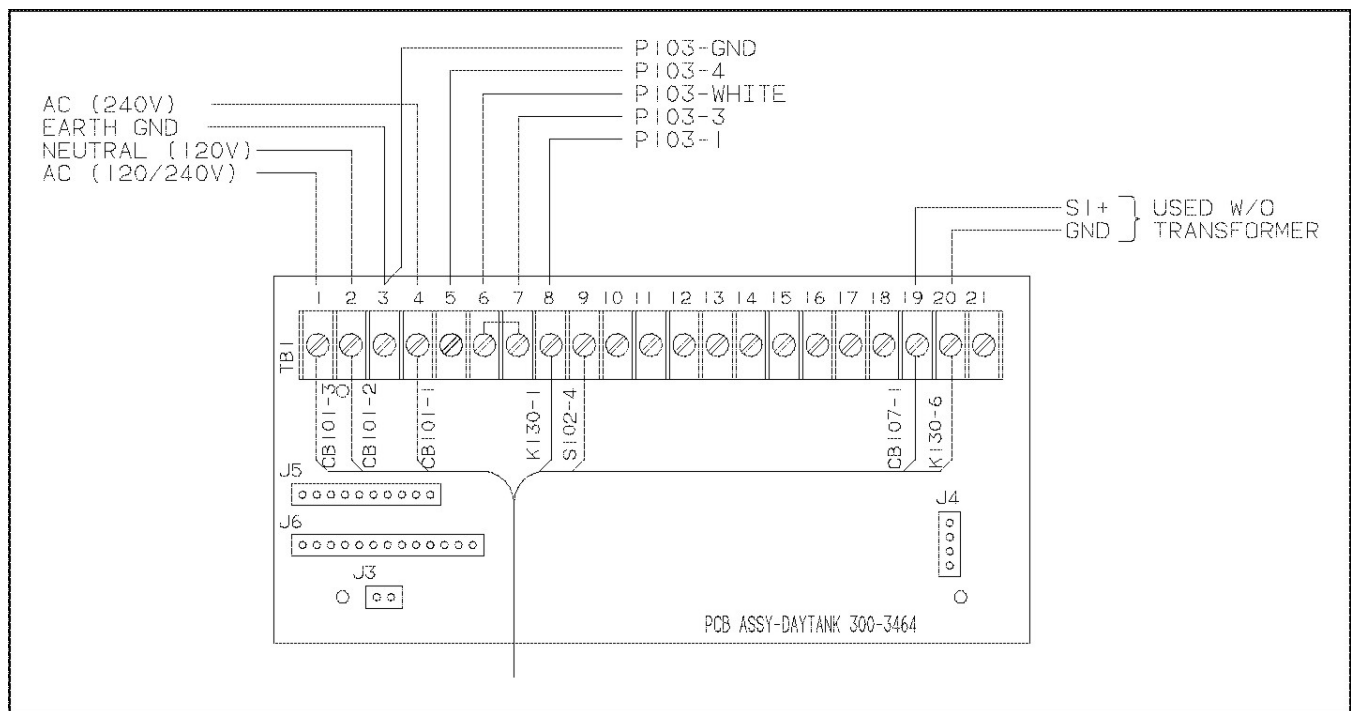

FIGURE 32. FUEL PUMP CONTROL TERMINAL BOARD

The following should be noted.

1. The control can be powered by 120 VAC or 240 VAC. The control is set up at the factory for connection to 240 VAC.

NOTICE

To convert the day tank controller from 240 VAC to 120 VAC, perform the following steps.

- a. Remove the two jumpers between terminals TB1-6 and TB1-7 in the control box, and connect one jumper between terminals TB1-5 and TB1-6 and the other jumper between terminals TB1-7 and TB1-8.
- b. Move selector switch S103 on the control PCB to the up position for 120 V.
- c. On the control transformer, remove the two jumpers between terminals H2 and H3, and connect one jumper between H1 and H3 and the other jumper between H2 and H4.

NOTICE

To convert the day tank controller from 120 VAC to 240 VAC, perform the following steps.

- a. Remove the jumpers between terminals TB1-5 and TB1-6 and TB1-7 and TB1-8 in the control box, and connect the two jumpers between terminals TB1-6 and TB1-7.
- b. Move selector switch S103 on the control PCB to the down position for 240 VAC.
- c. On the control transformer, remove the jumpers between terminals H1 and H3 and H2 and H4, and connect the two jumpers between H2 and H3.

2. Attach a tag to the control box indicating the supply voltage.
3. Terminals TB1-8 and TB1-5 are available for connection of a 120 VAC or 240 VAC electric fuel shutoff valve rated not more than 0.5 amps. The voltage rating of the valve must correspond with the voltage utilized for the pump.

9.8 Current Transformers

Current transformers (CTs) reduce high voltage currents (AC) to enable safe monitoring.

9.9 Coolant Heater

Coolant heaters are designed to allow the generator set to start and pick up load within 8.5 seconds in a 4.4 °C (40 °F) environment. In colder ambient temperature environments the starting time may be longer.

9.10 Alternator Heaters

9.10.1 Alternator Heater Connection

⚠ WARNING

Electric Shock Hazard

Voltages and currents present an electrical shock hazard that can cause severe burns or death.

Water or moisture inside an alternator increases the possibility of flashing and electrical shock.

Do not use an alternator which is not dry inside and out.

An alternator heater(s) is used to help keep the alternator free of condensation when the generator set is not running. During cool and humid conditions, condensation can form within an alternator, creating flashing and shock hazards.

Connect the heater(s) terminals to a source of power that will be on during the time the engine is not running. Be sure the supply voltage and circuit amperage is correct for the heater element rating.

9.11 Control Box Heater

9.11.1 Control Box Heater Installation

A thermostat controlled heater is installed inside the control cabinet. [Figure 33](#) shows a typical heater. [Figure 34](#) shows typical heater wiring. Also see the Wiring Diagrams section.

The control box heater power cord must be installed and connected to a grounded outlet.

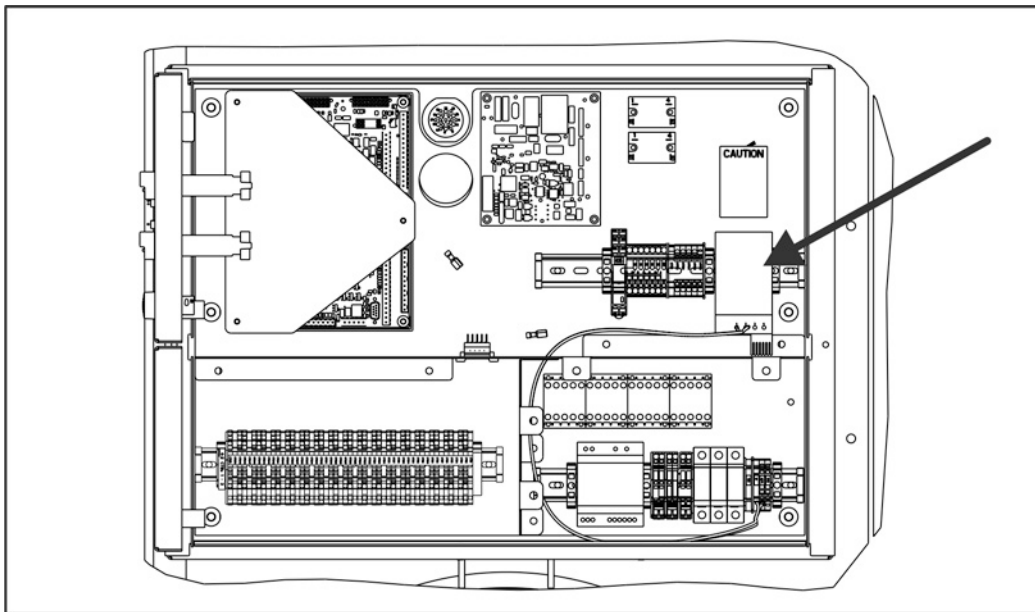

FIGURE 33. TYPICAL CONTROL BOX HEATER

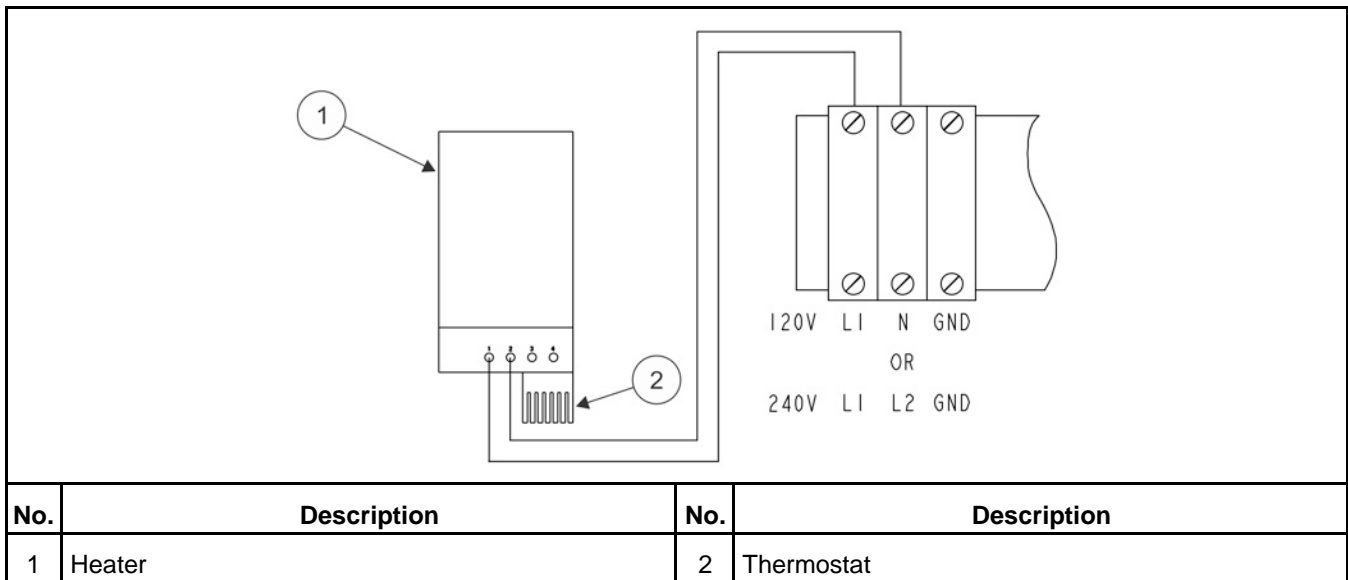

FIGURE 34. TYPICAL HEATER WIRING DIAGRAM

9.12 Battery Commissioning - Maintenance Free

NOTICE
 Commissioning is to be undertaken by suitably trained and qualified service personnel only.

The battery(s) are supplied and installed with 70% State of Charge (SOC), enough to start the generator set.

The set mounted battery charger will then charge the battery to the maximum level.

If the battery(s) have been disconnected/removed, the battery(s) will need commissioning:

- Pre-Commissioning Procedure
- Charging
- Fitting the Battery to the Generator Set

9.12.1 Safety Precautions

Servicing of batteries are to be performed or supervised by personnel knowledgeable of batteries and the required precautions. Keep unauthorized personnel away from batteries.

9.12.1.1 General Precautions

WARNING

Combustible Gases

Ignition of battery gases is a fire and explosion hazard which can cause severe personal injury or death.

Laying tools or metal objects across the battery can cause arcing. Never lay tools or metal objects across the top of the battery.

CAUTION

Electrical Shock

A battery presents a risk of electrical shock and high short circuit current which can cause minor or moderate injury.

Observe the following precautions when working on batteries.

- Use proper PPE. Remove jewelry such as watches, rings, or other metal objects. Remove any conductive items from pockets. These items can fall into equipment and result in a short circuit, which can cause shock or burning. Refer to local standards for PPE details (in the U.S: see NFPA 70).
- Keep batteries upright to prevent spillage. Electrolyte is a dilute sulphuric acid that is harmful to the skin and eyes.
- Use tools with insulated handles to prevent the risk of electric shock.

9.12.1.2 Fire Hazard

NOTICE

During the charging of a battery, explosive gases are given off. Keep the battery area well ventilated and away from naked flames and sparks. Do not smoke.

- Before disconnecting a battery, isolate the utility powered battery charger (where fitted).
- To disconnect the battery, use an insulated wrench to disconnect the negative cable first.
- To connect the battery, use an insulated wrench to connect the negative cable last.

9.12.1.3 Fluid Hazard

⚠ WARNING

Toxic Hazard

Contact with electrolyte can cause severe personal injury.

Wear appropriate PPE when handling electrolyte: acid-proof protective apron, goggles, rubber gloves and boots. If electrolyte is splashed on the skin or in the eyes, flush the affected areas immediately with water and seek medical attention.

⚠ WARNING

Hazardous Liquid

Uncontrolled chemical reactions can cause severe chemical burns or death.

Never add undiluted sulfuric acid to a battery.

9.12.2 Pre-Commissioning Procedure

1. Check for any damage to the battery case or terminals, and make sure that the battery is clean and dry.
2. Remove the vent plugs and break any seals (if present), taking care not to damage the plates or separators. The broken seal will fall into the bottom of the chamber and do no harm.

9.12.3 Filling the Battery with Electrolyte

1. Fill each cell of the battery with dilute sulphuric acid (electrolyte) of the correct specific gravity (SG) according to the levels on the battery label.
2. Filling must be completed in one step.
3. Allow the battery to soak for ten to fifteen minutes. If the electrolyte level has fallen, it should be restored by adding electrolyte of the correct SG to the levels given on the battery label.
4. After filling, place the battery on a commissioning charge within one hour. Charging must take place before any load is placed on the battery.

NOTICE

Failure to give a commissioning charge may impair the charge capacity and life of the battery.

9.12.4 Charging - Commissioning

1. Charge the battery for a minimum of four hours to ensure the acid is sufficiently mixed within the battery. If the battery has been in storage, check the manufacturer's instructions; the charging period may need extending.
2. When the generator set is running, check the charge alternator output using an induction ammeter.

9.12.5 Connecting the Battery to the Generator Set

NOTICE

A battery must not be fitted to a generator set without charge if the specific charge of the electrolyte has fallen below 1.240 during storage.

1. Secure the battery. Battery hold-down bolts must be tight, but not over-tight.
2. Smear the terminals with petroleum jelly, if necessary.
3. Fit the vents firmly in position and ensure that the battery is clean and dry.
4. Verify correct polarity when connecting the battery to the set. Even momentary incorrect connection can cause damage to the electrical system.
5. Use an insulated wrench connect the positive generator cable first, followed by the negative cable. Terminal connections must be tight, but not over-tight.

9.12.6 Electrolyte - Specific Gravity and Temperature

Maintenance-free batteries are sealed and do not require the addition of electrolyte. Some manufacturers of maintenance-free batteries provide an 'eye' or other visible means of telling when the battery is discharged or approaching the end of its useful life.

9.12.6.1 Checking Electrolyte Level

NOTICE

Never add tap or well water and never allow the battery electrolyte to drop below the top of the plates, otherwise damage will occur.

NOTICE

Do not add water in freezing weather unless the engine will run long enough (2 to 3 hours) to make sure that water and electrolyte are thoroughly mixed.

Check the level of the electrolyte (acid and water solution) in the batteries at least every month or 100 hours of operation, whichever occurs first. Maintain the electrolyte to the levels indicated on the battery label. Add distilled water only and recharge. Replace the vent plugs once filling is completed.

If a cell level is low, check the case for leaks.

Keep the battery case clean and dry. An accumulation of moisture will lead to a more rapid discharge and battery failure.

9.12.6.2 Checking Specific Gravity Using a Hydrometer

Use a hydrometer to check the specific gravity (SG) of the electrolyte in each battery cell.

Hold the hydrometer vertically and take the reading.

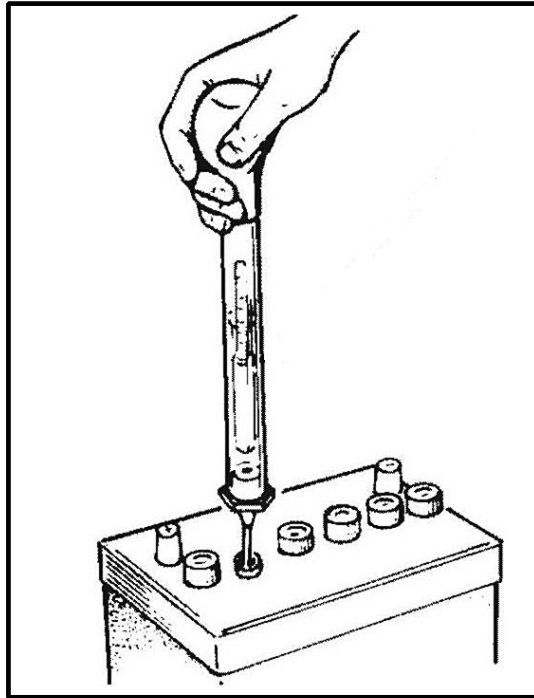

FIGURE 35. CHECKING SPECIFIC GRAVITY

9.12.6.3 Checking Specific Gravity Using an Acid Refractometer

Follow the instructions included with the refractometer. Obtain a small drop of liquid and place it under the clear plastic cover to check the specific gravity (SG) of the electrolyte in each battery cell.

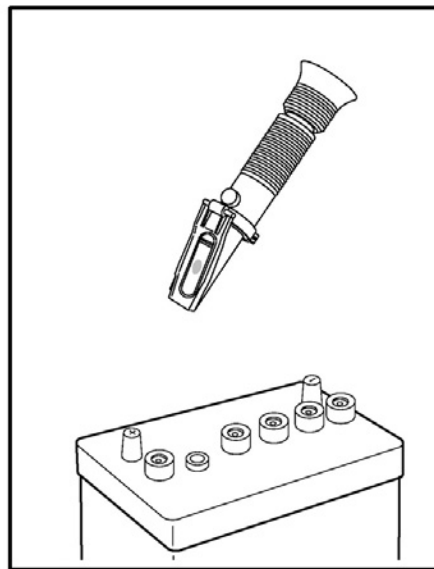

FIGURE 36. TYPICAL BATTERY ACID REFRACTOMETER

9.12.6.4 Specific Gravity Values for Batteries

A fully charged battery will have a corrected specific gravity (SG) of 1.260 at 25 °C (77 °F). Hold the hydrometer vertically and take the reading. Charge the battery if the reading is below 1.215. The table below shows the specific gravity of electrolyte, corrected to 25 °C (77 °F).

TABLE 11. SPECIFIC GRAVITY

Temperature	For Filling New Cells	At End of Charge
Ambient temperature normally below 32 °C (90 °F)	1.270	1.270–1.290
Ambient temperature frequently above 32 °C (90 °F)	1.240	1.240–1.260
Maximum permissible temperature of electrolyte during charge	45 °C (113 °F)	45 °C (113 °F)

Correct the specific gravity reading for other temperatures by subtracting seven gravity points (0.007) for every 10 °C (18 °F) when the electrolyte temperature is above 27 °C (80 °F). Apply the correction formula as follows:

- For every 10 °C (18 °F) above 25 °C (77 °F), subtract 0.007 (7 points)
- For every 10 °C (18 °F) below 25 °C (77 °F), add 0.007 (7 points)

For example: if the specific gravity at 25 °C (77 °F) is 1.260, then the specific gravity at 15 °C (59 °F) is 1.267.

9.13 Battery Charger

9.13.1 PowerCommand Battery Charger - 15 Amp at 12 Volt and 12 Amp at 24 Volt

There are two types of 15/12-Amp PowerCommand battery chargers. All 15/12-Amp battery chargers have a 20 Amp DC circuit breaker switch on the front of the battery charger. The 120, 208, and 240 VAC battery chargers include two 10 Amp AC circuit breaker switches, all other models include two AC fuse holders.

Refer to the battery charger Owner Manual (901-0107) for more information.

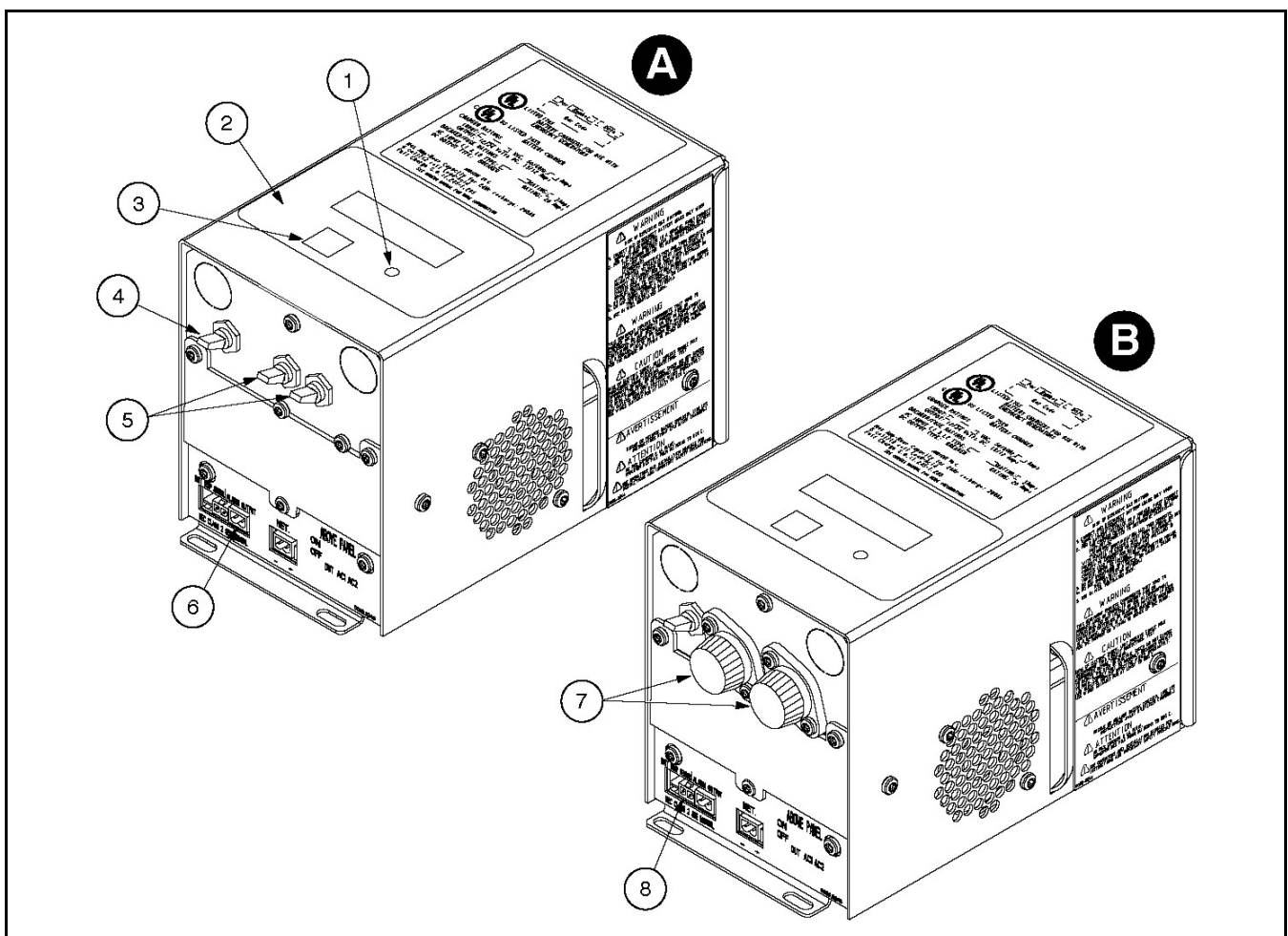

A	120, 208, and 240 VAC Battery Charger	4	20 Amp DC Circuit Breaker Switch (Shown in the "On" position)
B	Battery Charger with Fuse Holders	5	10 Amp AC Circuit Breaker Switches (Shown in the "On" position)
1	Status LED	6	Fault Alarm Output Connector
2	Control Panel	7	10 Amp AC Fuse Holders
3	Reset Button	8	Connector for Optional Battery Temperature Sensor

FIGURE 37. 15/12-AMP POWERCOMMAND BATTERY CHARGERS

9.14 Grounding

⚠ WARNING

Electric Shock Hazard
Voltages and currents present an electrical shock hazard that can cause severe burns or death. Make sure that only service personnel who are trained and experienced perform electrical and mechanical component installations. Bonding and grounding must be done properly. All metallic parts that could become energized under abnormal conditions must be properly grounded.

The following is a brief description of system and equipment grounding of permanently installed AC generators within a facility wiring system.

NOTICE

It is important to follow the requirements of the local electrical code.

NOTICE

A UL-listed grounding electrode terminal within its ratings and suitable for the application must be installed and labeled "Grounding Electrode Terminal" for UL compliance.

[Figure 38](#), [Figure 39](#) and [Figure 40](#) illustrate typical system grounding for a 2-pole, 3-pole, and 4-pole Automatic Transfer Switch (ATS). In the 2-pole and 3-pole ATS, note that the generator neutral is connected to the ATS and is NOT bonded to ground at the generator. In the 4-pole ATS system, a grounding electrode conductor and a bonding jumper are used to connect the generator neutral to ground.

Make sure the generator set is grounded to earth in one location only. On generator sets without a circuit breaker, ground to the point indicated on the top of the generator. On generator sets with circuit breakers, use the ground lug provided in the circuit breaker box.

The grounding electrode terminal is not provided. Make sure UL listed terminals are used, are sized for the generator set ratings, and are suitable for the application.

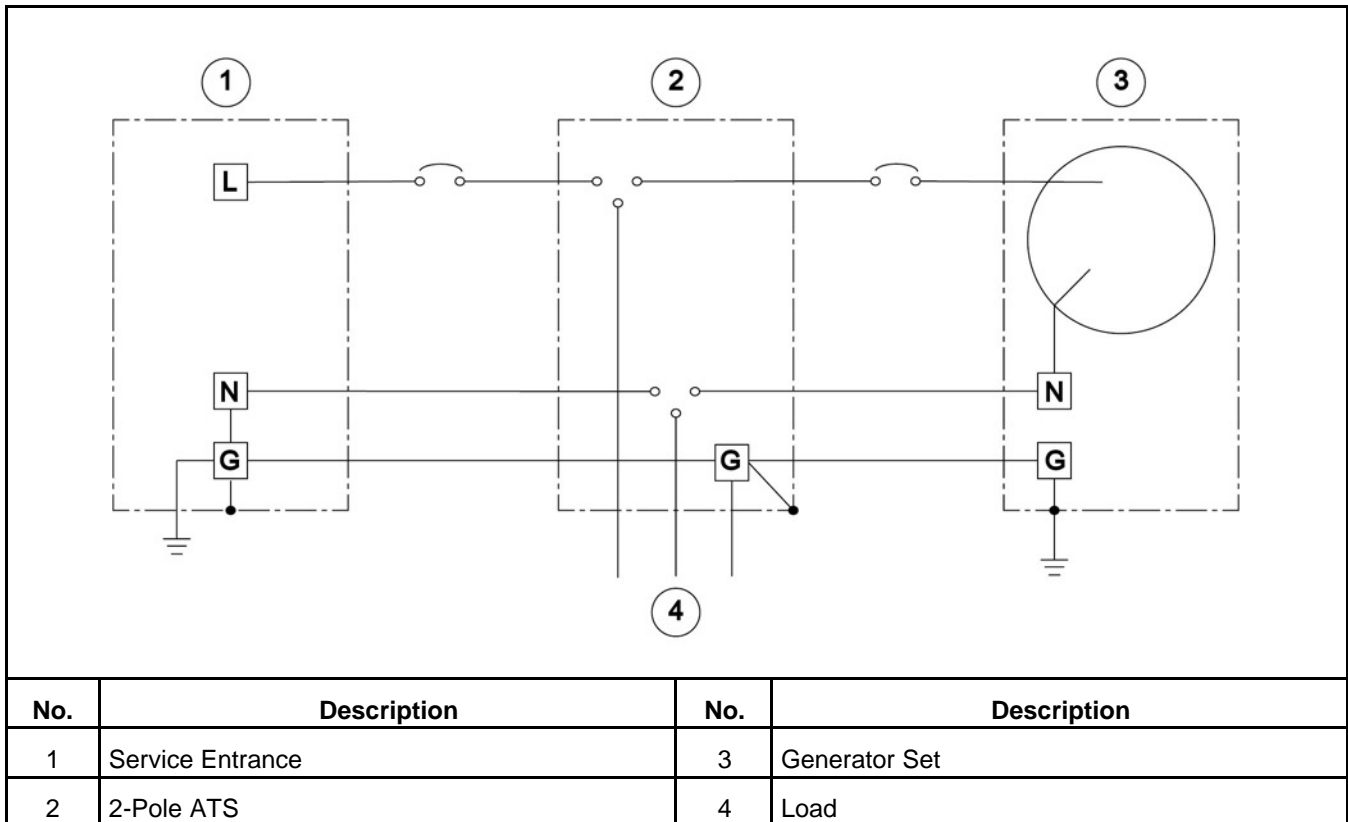

FIGURE 38. TYPICAL SYSTEM - ONE-PHASE, THREE WIRE UTILITY, TWO-POLE ATS

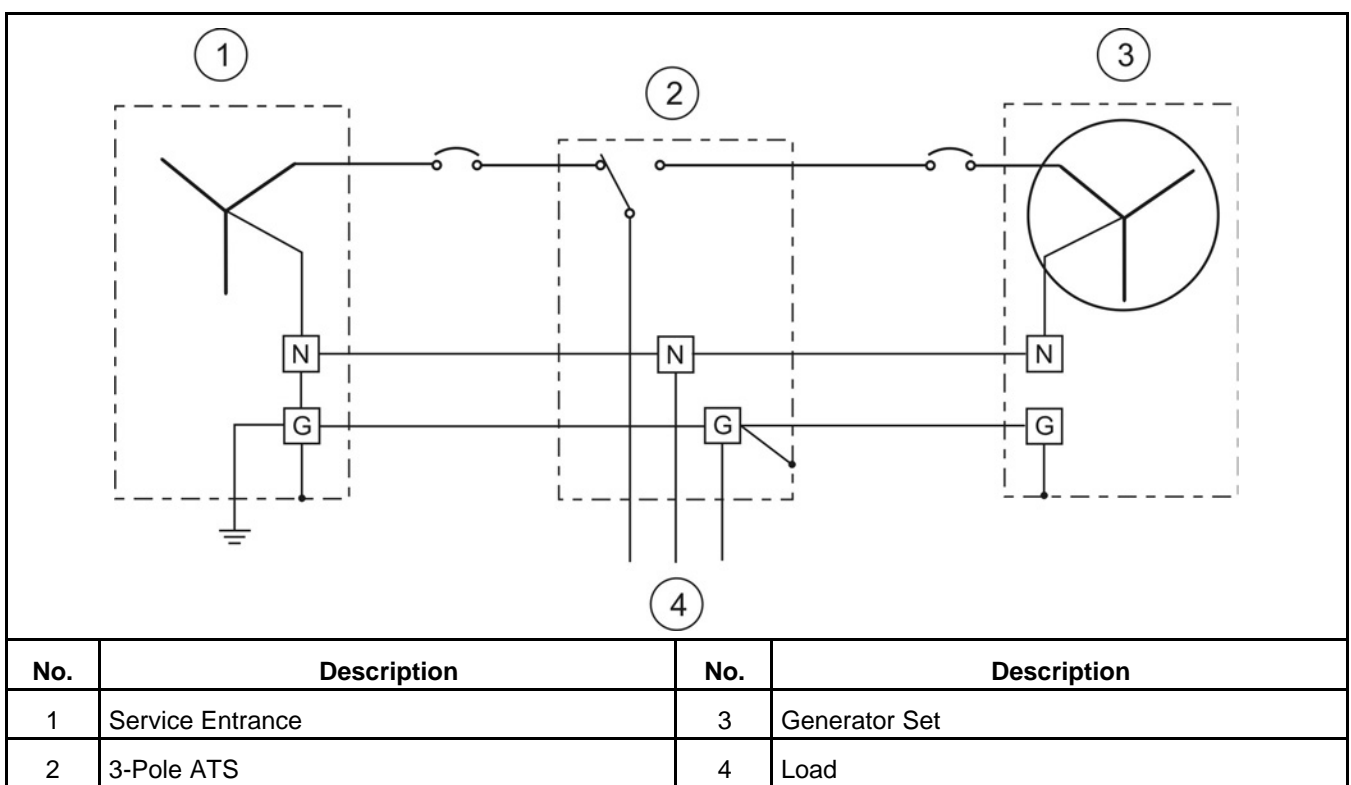

FIGURE 39. TYPICAL SYSTEM - THREE-PHASE, FOUR WIRE UTILITY, THREE-POLE ATS

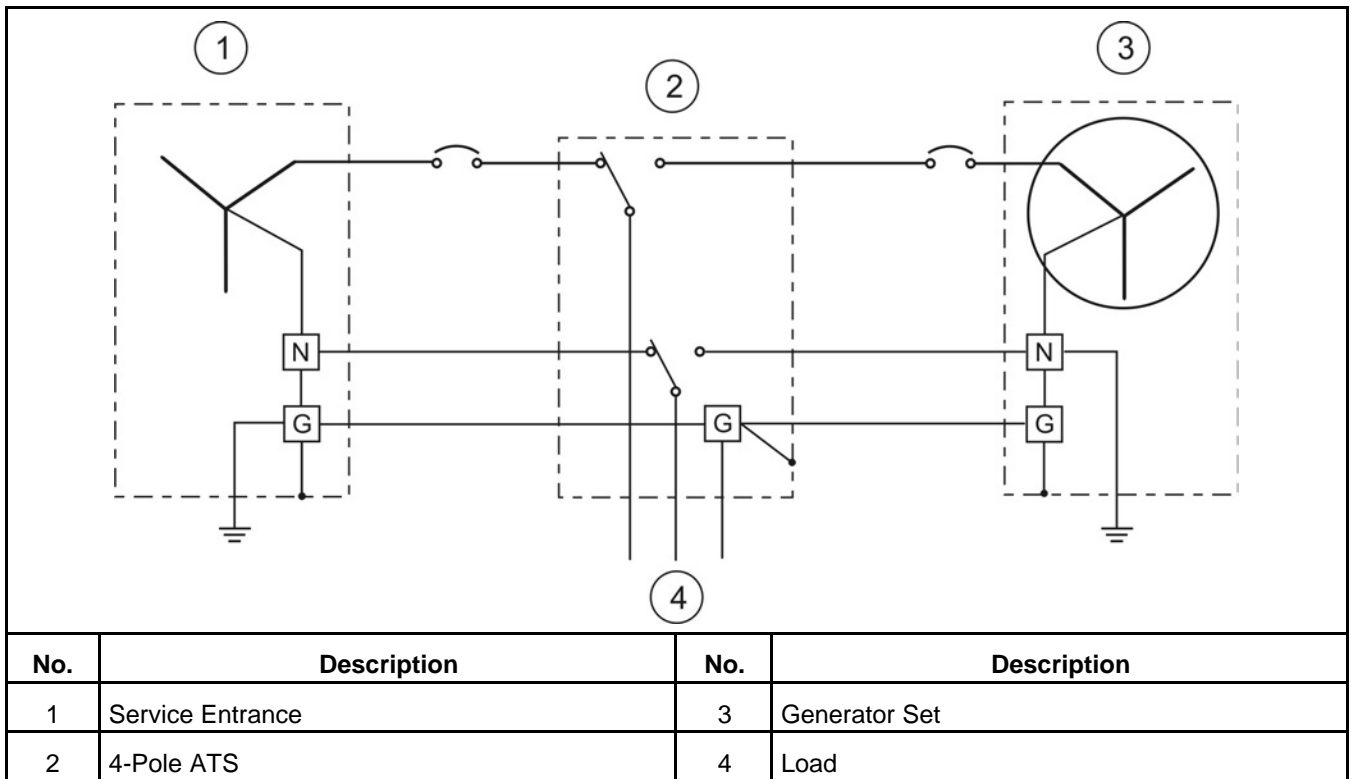

FIGURE 40. TYPICAL SYSTEM - THREE-PHASE, FOUR WIRE UTILITY, FOUR-POLE ATS

This page is intentionally blank.

10 Pre-Start Preparation

WARNING

Electrical Generating Equipment

Incorrect operation and maintenance can result in severe personal injury or death.

Make sure that only suitably trained and experienced service personnel perform electrical and/or mechanical service.

Before an initial start of the generator set, complete the Installation Checklist, see [Chapter 11 on page 93](#).

10.1 Initial Pre-start Checks

WARNING

Electric Shock Hazard

Voltages and currents present an electrical shock hazard that can cause severe burns or death.

Make sure that only personnel who are trained and experienced work with distribution voltages. Even after generator set shutdown, an electrical shock hazard may still exist, caused by induced or residual voltage within the alternator or cables. Some interfaces may display zero voltage even when voltages are present.

WARNING

Hot Pressurized Liquid

Contact with hot liquid can cause severe burns.

Do not open the pressure cap while the engine is running. Let the engine cool down before removing the cap. Turn the cap slowly and do not open it fully until the pressure has been relieved.

Before starting, be sure competent personnel have made the following checks to ensure that the unit is ready for operation:

- Generator Set Grounding – Grounding (Earthing) must be checked prior to performing service or inspection procedures that may expose personnel to conductors normally energized with voltages greater than 600 Volts. Contact your authorized distributor.
- Megger and Insulation Testing – This must be performed on all generator sets before initial start-up and after the generator set Grounding Procedure has been completed. Insulation testing for low voltage (less than 600 Volts) generator sets is recommended by Cummins. These tests are used to verify that the windings are dry before the generator set is operated, and to develop a base line for future test comparisons. Contact your authorized distributor.

NOTICE

When Megger testing an alternator, failure to protect the voltage regulator, control and diodes could result in permanent damage to one or more of the electronic components.

- Lubrication – Check the engine lubrication oil level and ensure that the correct level is always maintained.

NOTICE

Generator sets may be shipped dry. They must be filled with the correct type and quantity of oil before use. Be sure to check oil level before initial start. Failure to fill to the recommended level can result in equipment damage.

- Coolant – Check the engine coolant level and ensure that the level is always maintained. Fill the cooling system to the bottom of the fill neck in the radiator fill or expansion tank. Do not check while the engine is hot.

NOTICE

It is essential that Cummins recommendations for the correct type and concentration of anti-freeze and DCA inhibitor are complied with. Warranty claims for damage will be rejected if the incorrect mix has been used. Consult your authorized distributor for the correct anti-freeze specifications and concentration for your operating conditions.

NOTICE

Some radiators have two fill necks, both of which must be filled after the cooling system has been drained.

NOTICE

Generator sets may be shipped dry. They must be filled with the correct type and quantity of coolant before use. Be sure to check coolant level, or levels, before initial start. Refer to cooling system instructions in the Operator Manual.

10.2 Electrical System

Verify all electrical connections are secure and all wiring is complete and inspected. Replace and secure any access panels that may have been removed during installation.

10.3 Battery Connections

⚠ WARNING***Automated Machinery***

Accidental or remote starting of the generator set can cause severe personal injury or death.

Make sure that the generator set cannot be started accidentally or remotely before starting work on the generator.

⚠ WARNING***Combustible Gases***

Ignition of battery gases is a fire and explosion hazard which can cause severe personal injury or death.

Do not smoke, or switch the trouble light ON or OFF near a battery. Touch a grounded metal surface first before touching batteries to discharge static electricity. Stop the generator set and disconnect the battery charger before disconnecting battery cables. Using an insulated wrench, disconnect the negative (–) cable first and reconnect it last.

Starting the unit requires one or more batteries. For more information on batteries, refer to the Model Specifications section. To prevent arcing, use an insulated wrench to connect the positive battery cable, then connect the negative battery cable.

If an automatic transfer switch is installed without a built-in charge circuit, connect a separate battery charger. Proper selection and maintenance of batteries and battery chargers is essential for system reliability.

10.4 Site-Specific Configuration

NOTICE

Site-specific configuration is to be undertaken by suitably trained and qualified service personnel only.

The generator set is configured at the factory. Before starting the generator set, any site-specific configuration should be completed by qualified service personnel.

10.5 Starting

Refer to the generator set Operator manual for important safety precautions and recommended procedures for starting the generator set and verifying proper operation. Start the generator set and verify all engine and generator set menus are displaying the correct values.

This page is intentionally blank.

11 Installation Checklist

11.1 Checklist

Tick	General Items
	Generator set output is sufficient to handle maximum anticipated load.
	At least 0.9 m (3 feet) of clearance (or greater for housing door) is provided around the entire generator set for service and ventilation.
	The generator set is located in an area not subject to flooding.
	All operating personnel have read and are familiar with the generator set Operator manual, all health and safety procedures, warnings, cautions, precautions, and the other documentation supplied with the generator set.
	All operators have been thoroughly briefed on preventative maintenance procedures.
	All operators have read and understand all important safety instructions.
	Any parts requiring software have been checked for the latest version. Contact the service representative for more information.
	Generator Set Position
	The floor, roof, or earth on which the generator set rests is strong enough and will not allow shifting or movement. Observe local codes on soil bearing capacity due to freezing and thawing.
	The generator set is properly supported and retained to an approved base.
	The supporting base is large enough and is of non-combustible material, extending 15 cm (6 inches) all around the generator set.
	Provisions have been made for site specific environmental operating conditions (weather protection, proximity to coastline, dusty environments, etc.,)
	Cooling Air Flow
	Generator set air inlet is faced into the direction of strongest, prevailing winds.
	Air inlet openings are unrestricted and are at least 1 to 1½ times larger than air outlet area.
	Cooling air outlet is on downwind side of building (if not, a wind barrier is constructed).
	Proper ducting material (sheet metal, canvas) is used between radiator and air outlet.
	Diesel Fuel System (if applicable)
	Fuel tanks meet or exceed all local, State, or National codes (if applicable).
	Fuel lines are properly installed, supported, and protected against damage.
	The fuel filters have been installed.
	Approved flexible fuel line is installed between the main fuel supply and the generator set's fuel system near the generator set, to protect it against damage caused by vibration, expansion, and contraction.
	Strainer or fuel screen (100 to 200 mesh) is installed in the fuel supply line to protect the fuel lift pump, day tank transfer pump, or float valve seat from fuel tank debris (if applicable).
	The fuel filter assembly shipped with the generator set is installed and operational (if applicable).

	Fuel supply shutoff valves are installed to prevent fuel flow in case of leaks.
	No shutoff valves are installed on engine fuel return line (if applicable).
	External fuel pumps are connected and operational at all times - generator set started or shut down (if applicable).
	Fuel tanks are filled with the correct grade / type of fuel (if applicable).
	Fuel system is properly primed.
	No fuel leaks are found in supply line or engine fuel system.
	Exhaust System
	The breather tube routing is set up to blow the fumes away from the generator set (if applicable)
	Operators are thoroughly briefed on the dangers of carbon monoxide gas.
	If the installation includes a heavy duty air cleaner, it has been installed.
	Areas around generator set are well ventilated, with no possibility of exhaust fumes entering building doors, windows, or intake fans.
	Exhaust gases are piped safely outside and away from building.
	The correct length of approved rigid pipe is connected to the generator set flexible pipe using approved securing methods with no weight resting on engine exhaust components. There are no bends in flex section.
	Condensation drain is provided in lowest section of exhaust piping.
	Exhaust piping is insulated to guard against burns to personnel.
	Exhaust piping passing through walls or ceilings have approved fire-proof materials and are in compliance with all codes.
	Exhaust piping is large enough in diameter to prevent excessive back pressure on engine.
	Verify that the pyrometer meters are functioning.
	AC and DC Wiring
	For bottom entry circuit breaker installations, the cable chute has been installed (if applicable).
	Wire sizes, insulation, conduits and connection methods all meet applicable codes.
	AC and DC wires are separated in their own conduit to prevent electrical induction.
	All load, line and generator connections are well made and correct.
	Flexible conduit is used between the generator and the building or surrounding structure.
	Check phase rotation.
	Generator Set Pre-Start
	Generator set engine is properly serviced with oil and coolant.
	Battery charger is installed using the appropriate cable size and is operational.
	Battery charger is configured for the proper DC battery voltage, battery type, and float voltage.
	Batteries are properly installed, serviced and charged.
	Battery temperature sensor is connected and operational (if applicable).
	Cooling system is filled with correct volume and concentration of coolant. The water used in the coolant mix has passed water quality check.

	Engine coolant heater is connected and operational.
	All generator set covers and safety shields are installed correctly.
	All fuel and coolant shutoff valves are operational.
	Shipping brackets are removed.
	Radiator fan and other external moving parts, including drive belts, are unrestricted.

This page is intentionally blank.

12 Manufacturing Facilities

U.S. and CANADA	EMEA, CIS	BRAZIL
Cummins Inc. 1400 73rd Ave. NE Minneapolis, MN 55432 USA	Cummins Inc. Royal Oak Way South Daventry Northamptonshire NN11 8NU United Kingdom	Rua Jati, 310, Cumbica Guarulhos, SP 07180-900 CNPJ: 43.2201.151/0001-10 Brazil
Toll Free 1-800-CUMMINS™ (1-800-286-6467) Fax +1 763-574-5298	Phone +44 1327 88-6453 Fax +44 1327 88-6125	Phone 0800 286 6467
CHINA	INDIA	ASIA PACIFIC
Cummins Inc. No.118 South Quanli Road , Wuhan Economic& Technological Development Zone , Hubei, P.R.China 430058	Cummins Inc. Plot No B-2, SEZ Industrial Area, Village-Nandal & Surwadi, Taluka- Phaltan Dist- Satara, Maharashtra 415523 India	Cummins Sales and Service Singapore Pte Ltd 85 Tuas South Avenue 1 Singapore 637419
Phone + 86 (27) 8421 4008 Fax + 86 (27) 8421 4804	Phone +91 021 66305514	Fax +65 6265 6909
LATIN AMERICA	MEXICO	
3350 Southwest 148th Ave. Suite 205 Miramar, FL 33027 USA	Eje 122 No. 200 Zona Industrial San Luis Potosi, S.L.P. 78395 Mexico Eje 120 No. 201 Zona Industrial San Luis Potosi, S.L.P. 78395 Mexico	
Phone +1 954 431 551 Fax +1 954 433 5797	Phone +52 444 870 6700 Fax +52 444 824 0082	

12.1 How to Obtain Service

When a product requires servicing, contact the nearest Cummins service provider. To locate the distributor, go to www.cummins.com/support and select Find a Sales or Service Location. When contacting the service provider, always supply the complete model, specification, and serial number as shown on the nameplate.

12.1.1 Locating a Distributor

In the U.S. and Canada

To easily locate the nearest certified distributor/dealer for Cummins generator sets in your area, or for more information, contact us at 1-800-CUMMINS™ (1-800-286-6467) or visit www.cummins.com/support.

If unable to contact a distributor using the automated service, consult the Internet.

If unable to arrange a service or resolve an issue, contact the Service Manager at the nearest Cummins distributor for assistance.

When contacting the distributor, always supply the complete Model, Specification, and Serial Number as shown on the product nameplate.

Appendix A. Alternator Reconnect Drawing

Table of Contents

Figure 41. HC Alternator Sheet 1 of 2 101
Figure 42. Sheet 2 of 2 102
Figure 43. 0630-2459 (Sheet 1 of 7) 103
Figure 44. 0630-2459 (Sheet 2 of 7) 104
Figure 45. 0630-2459 (Sheet 3 of 7) 105
Figure 46. 0630-2459 (Sheet 4 of 7) 106
Figure 47. 0630-2459 (Sheet 5 of 7) 107
Figure 48. 0630-2459 (Sheet 6 of 7) 108
Figure 49. 0630-2459 (Sheet 7 of 7) 109

The drawings included in this section are representative. For current complete information, refer to the drawing package that was shipped with the unit.

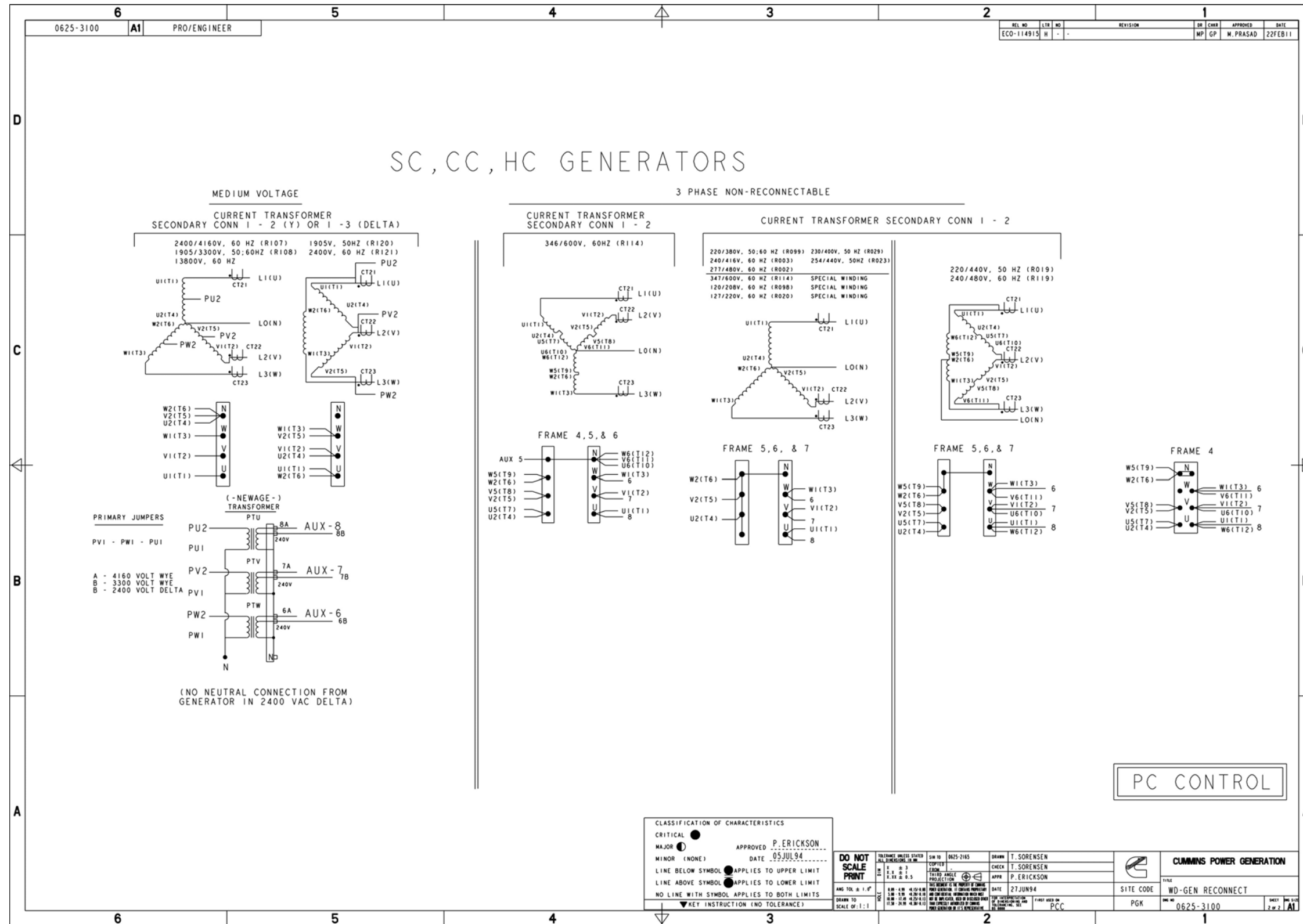

FIGURE 42. SHEET 2 OF 2

A.2 Alternator Reconnect Drawing

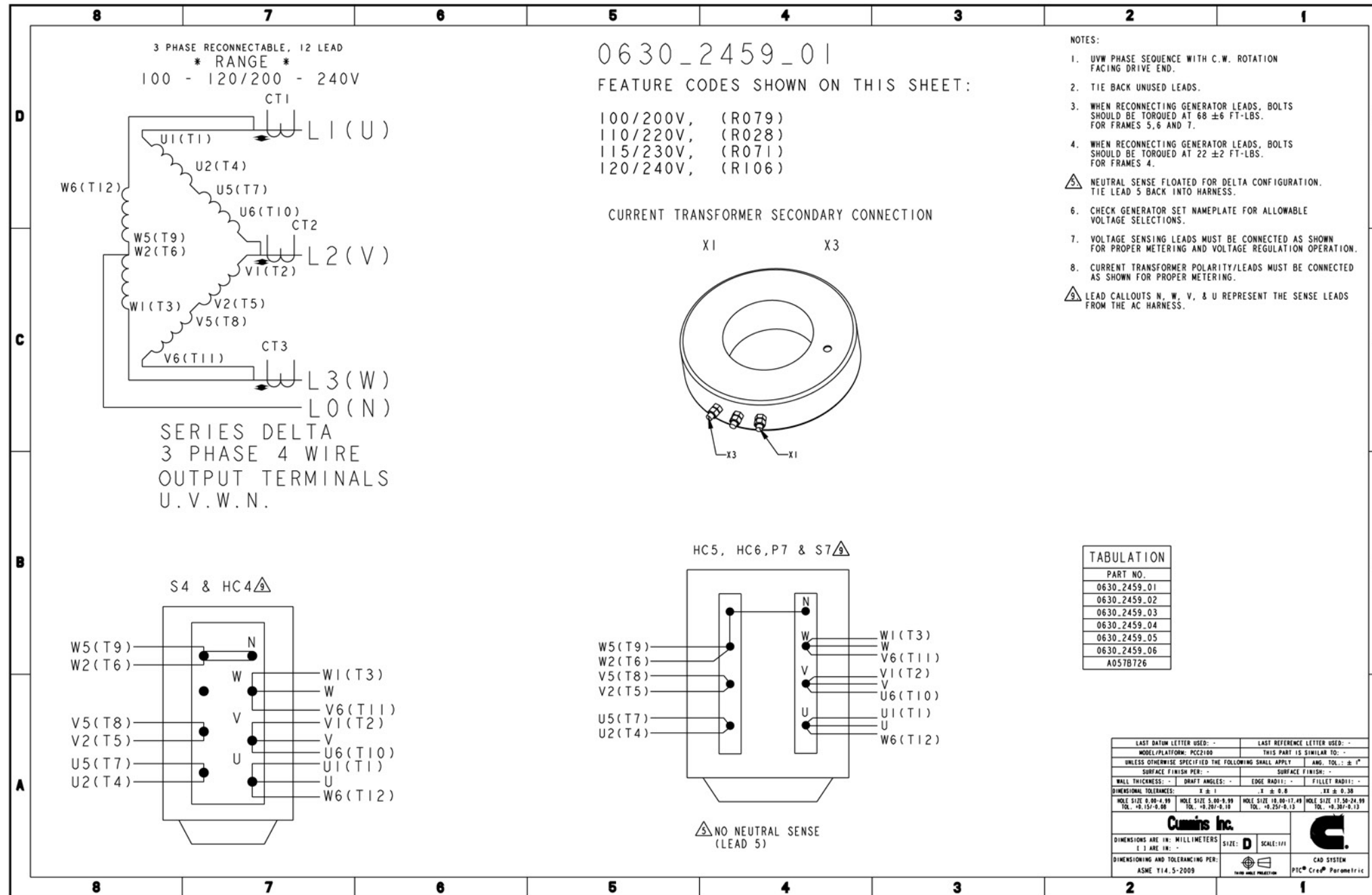

FIGURE 43. 0630-2459 (SHEET 1 OF 7)

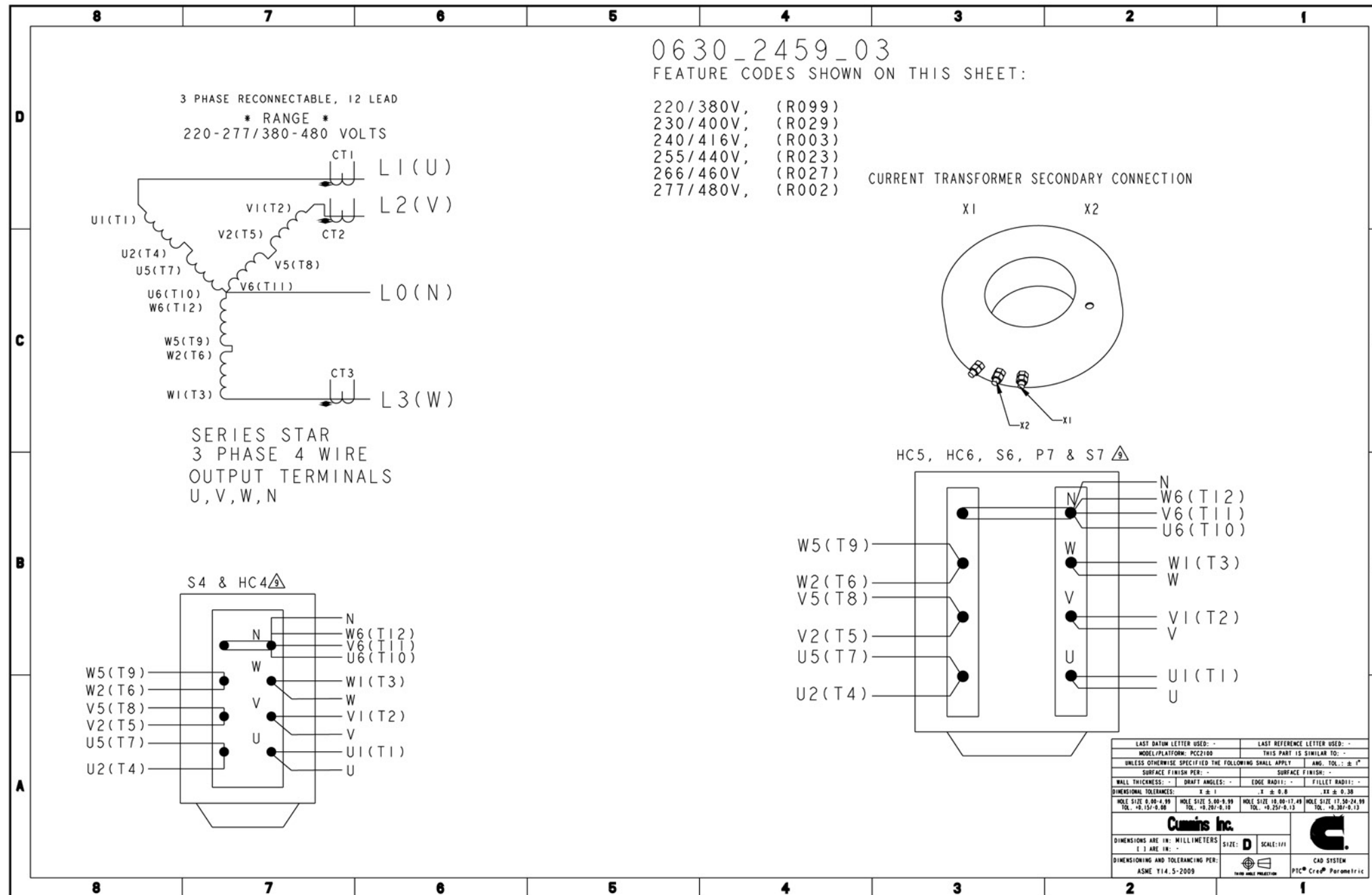

FIGURE 45. 0630-2459 (SHEET 3 OF 7)

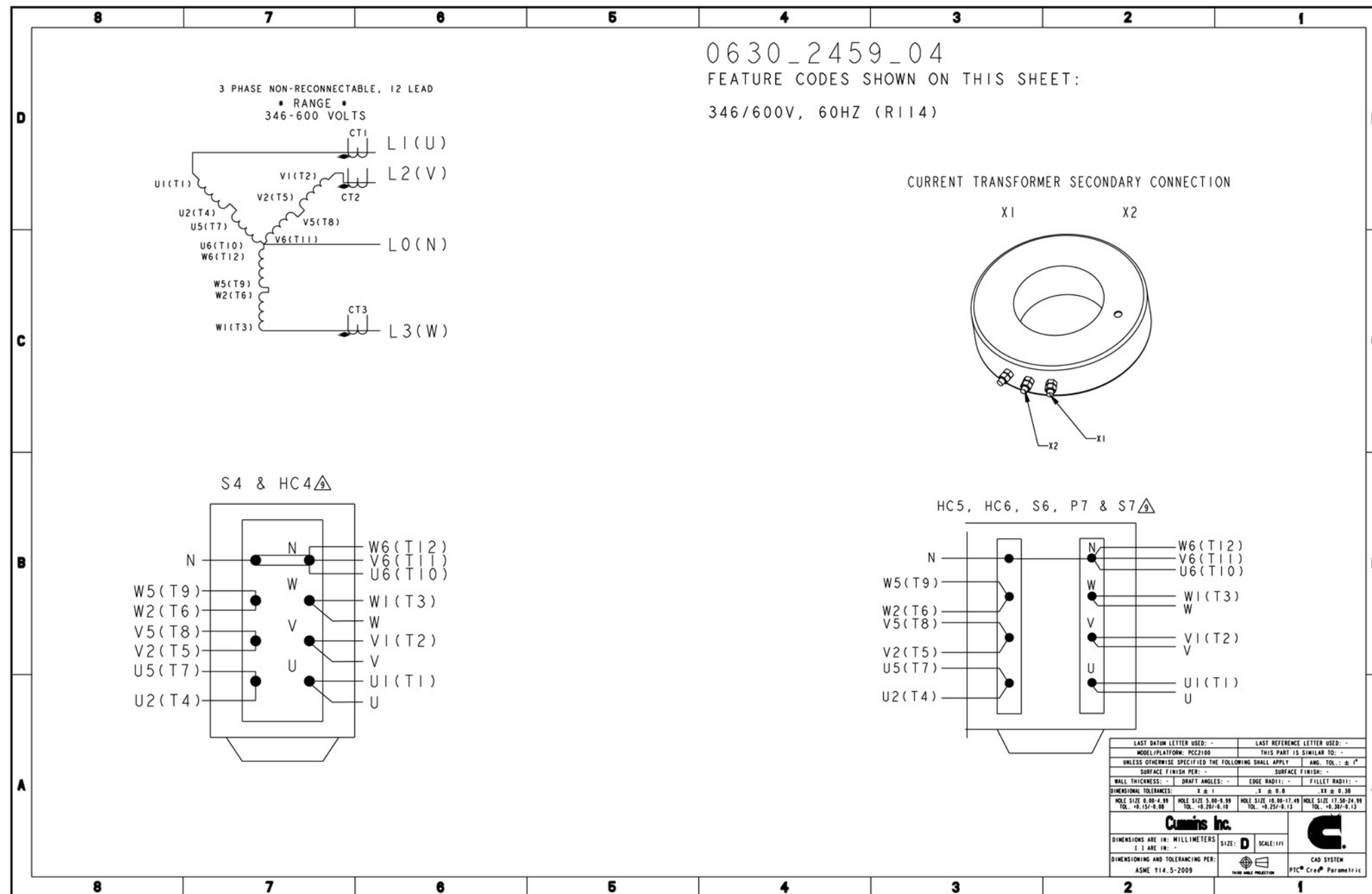

FIGURE 46. 0630-2459 (SHEET 4 OF 7)

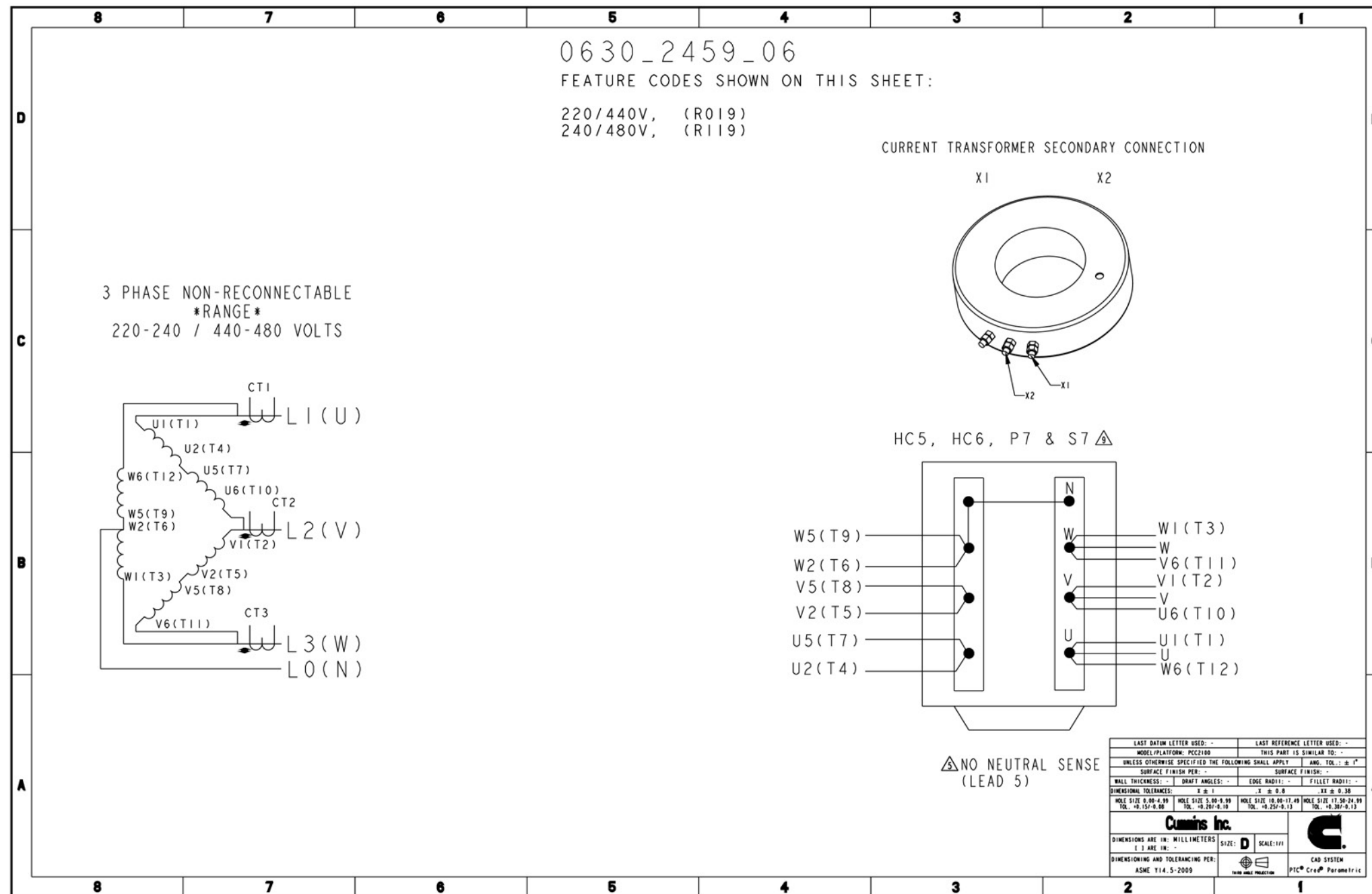

FIGURE 48. 0630-2459 (SHEET 6 OF 7)

This page is intentionally blank.

Appendix B. Customer Connections

Table of Contents

- Figure 50. Control Customer Connections - PCC Net Devices 113
- Figure 51. Customer Connections 114
- Figure 52. PowerCommand 3.3 Connections - ECM-Based Engines 115
- Figure 53. PowerCommand 3.3 Connections - Hydromechanical Engine 116
- Figure 54. PowerCommand 3.3 Paralleling Connections - Standalone Generator Set 117
- Figure 55. PowerCommand 3.3 Paralleling Connections - Synchronize Only 118
- Figure 56. PowerCommand 3.3 Paralleling Connections - Isolated Bus Only 119
- Figure 57. PowerCommand 3.3 Paralleling Connections - Utility Single 120
- Figure 58. PowerCommand 3.3 Paralleling Connections - Utility Multiple 121
- Figure 59. PowerCommand 3.3 Paralleling Connections - Power Transfer Control 122
- Figure 60. PowerCommand 3.3 Paralleling Connections - Configurable Paralleling I/O 123

The drawings included in this section are representative. For current complete information, refer to the drawing package that was shipped with the unit.

B.1 Control Wiring Diagrams (0630-3440)

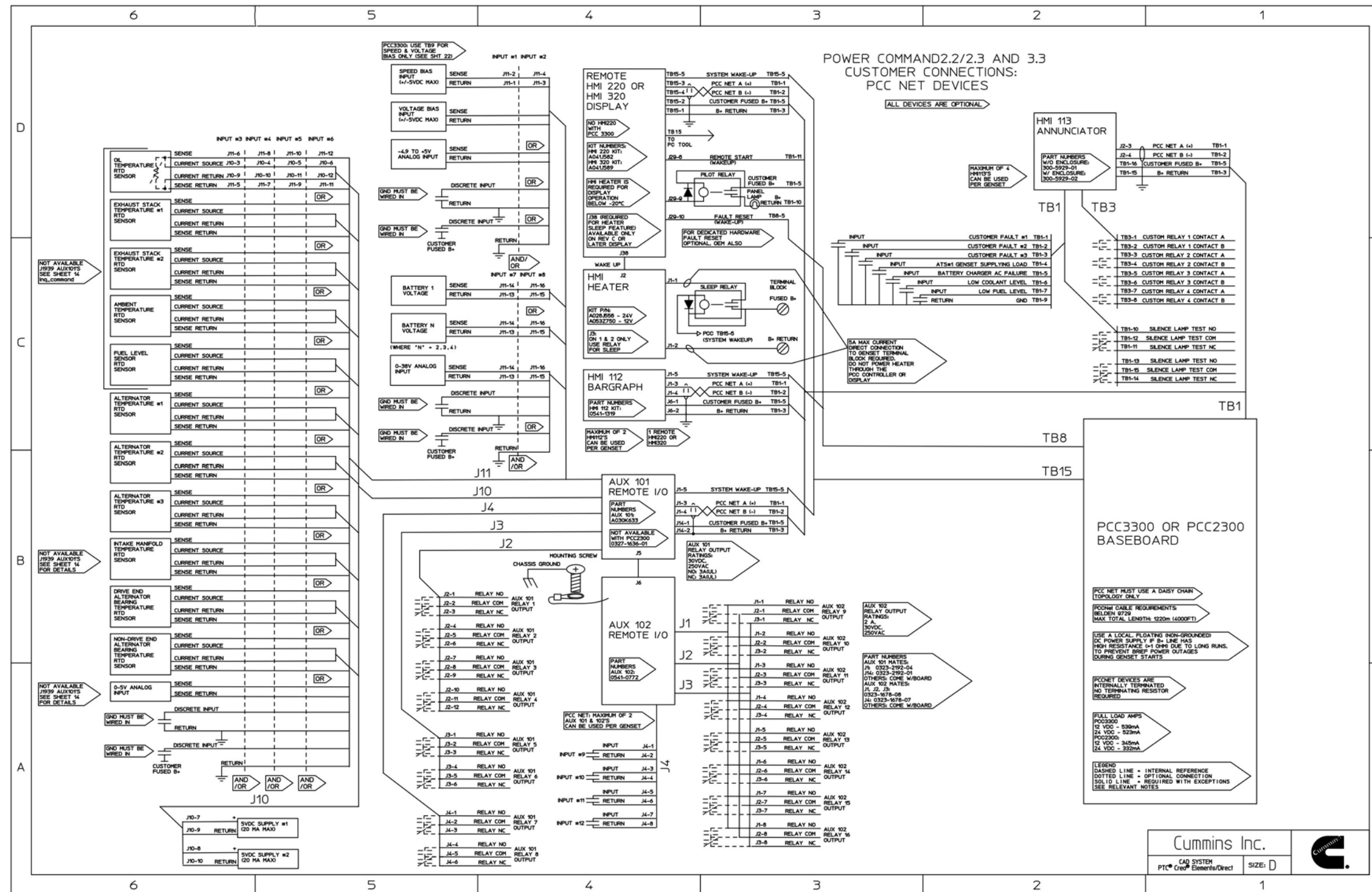

FIGURE 50. CONTROL CUSTOMER CONNECTIONS - PCC NET DEVICES

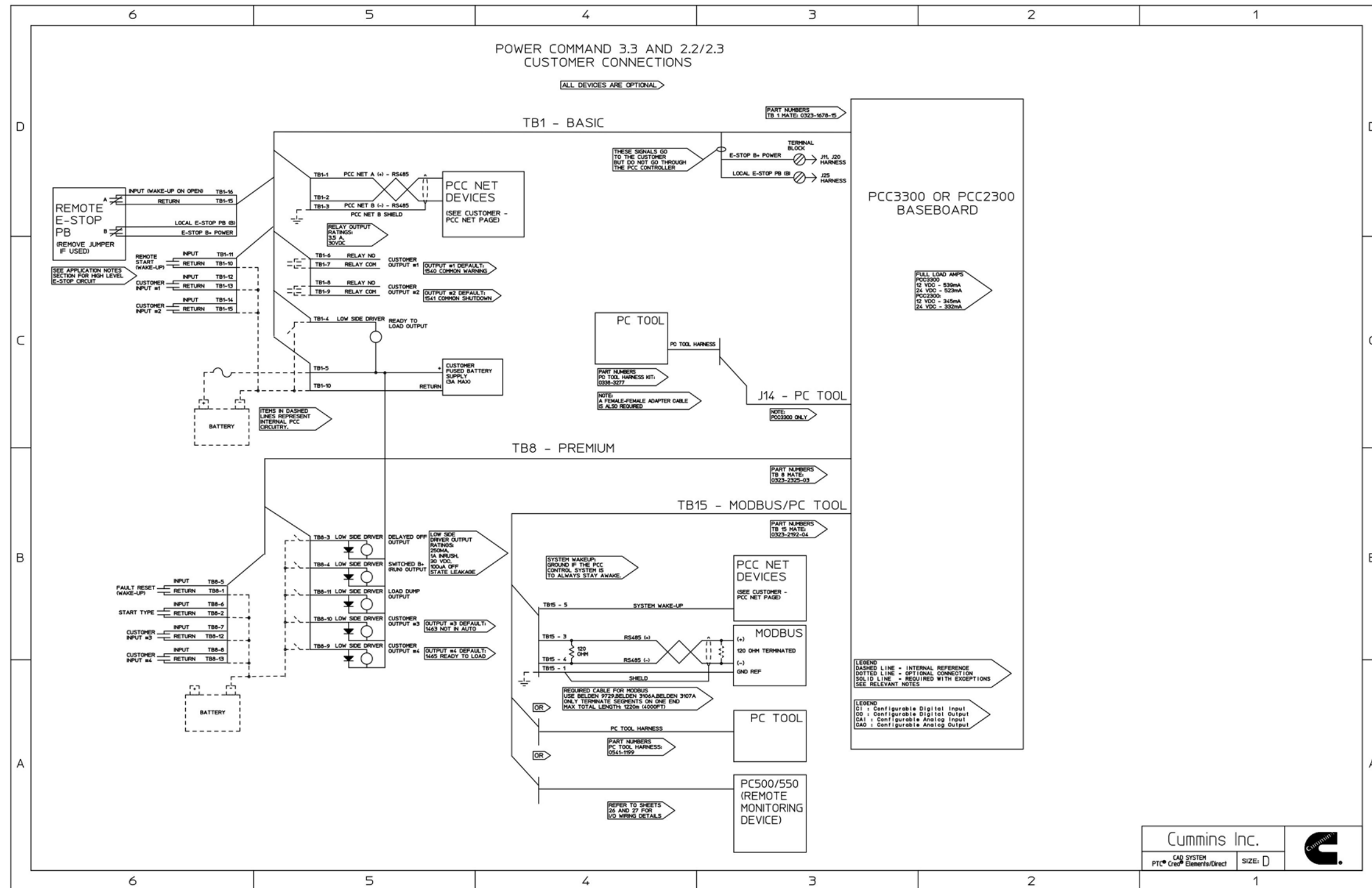

FIGURE 51. CUSTOMER CONNECTIONS

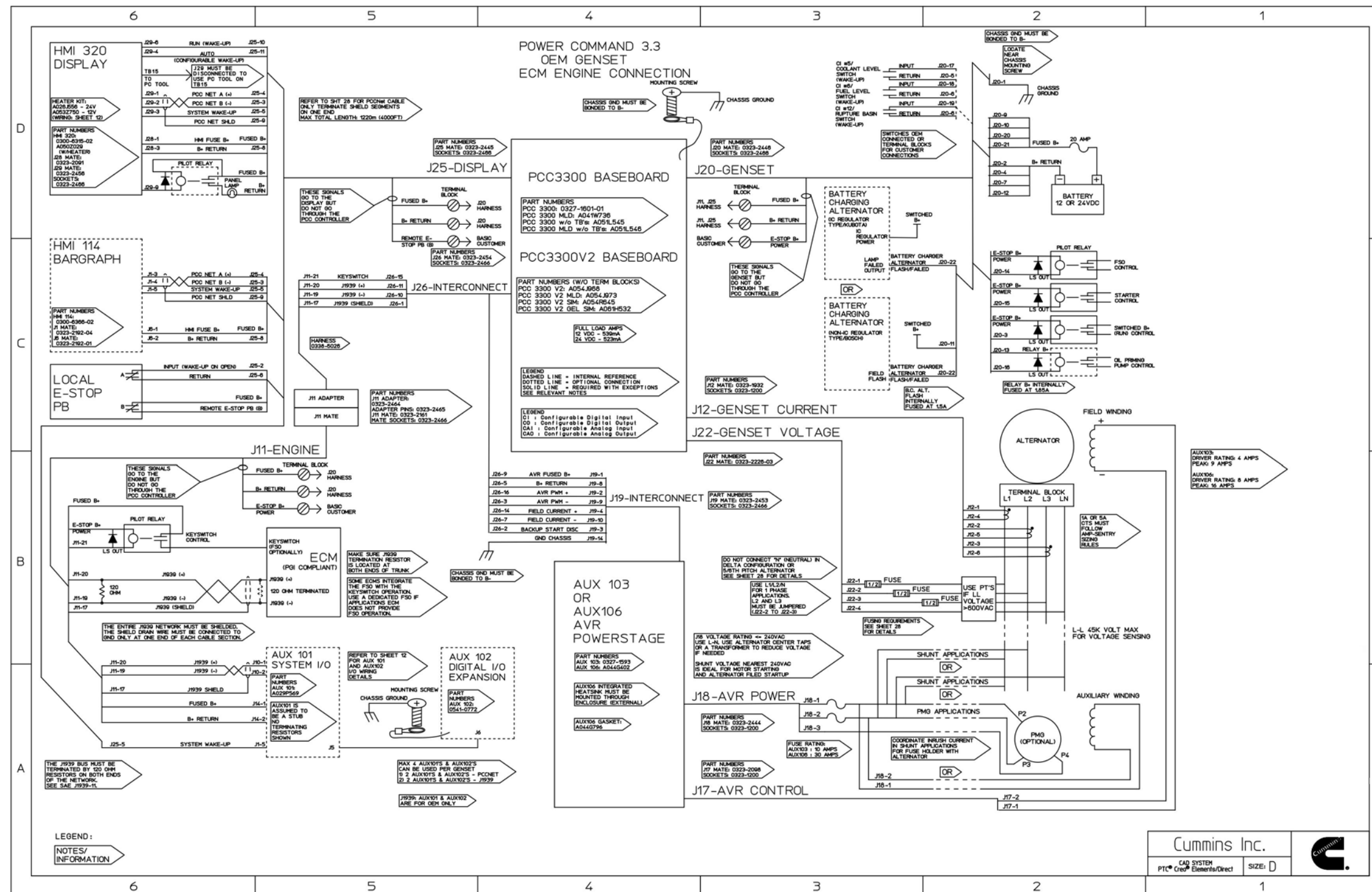

FIGURE 52. POWERCOMMAND 3.3 CONNECTIONS - ECM-BASED ENGINES

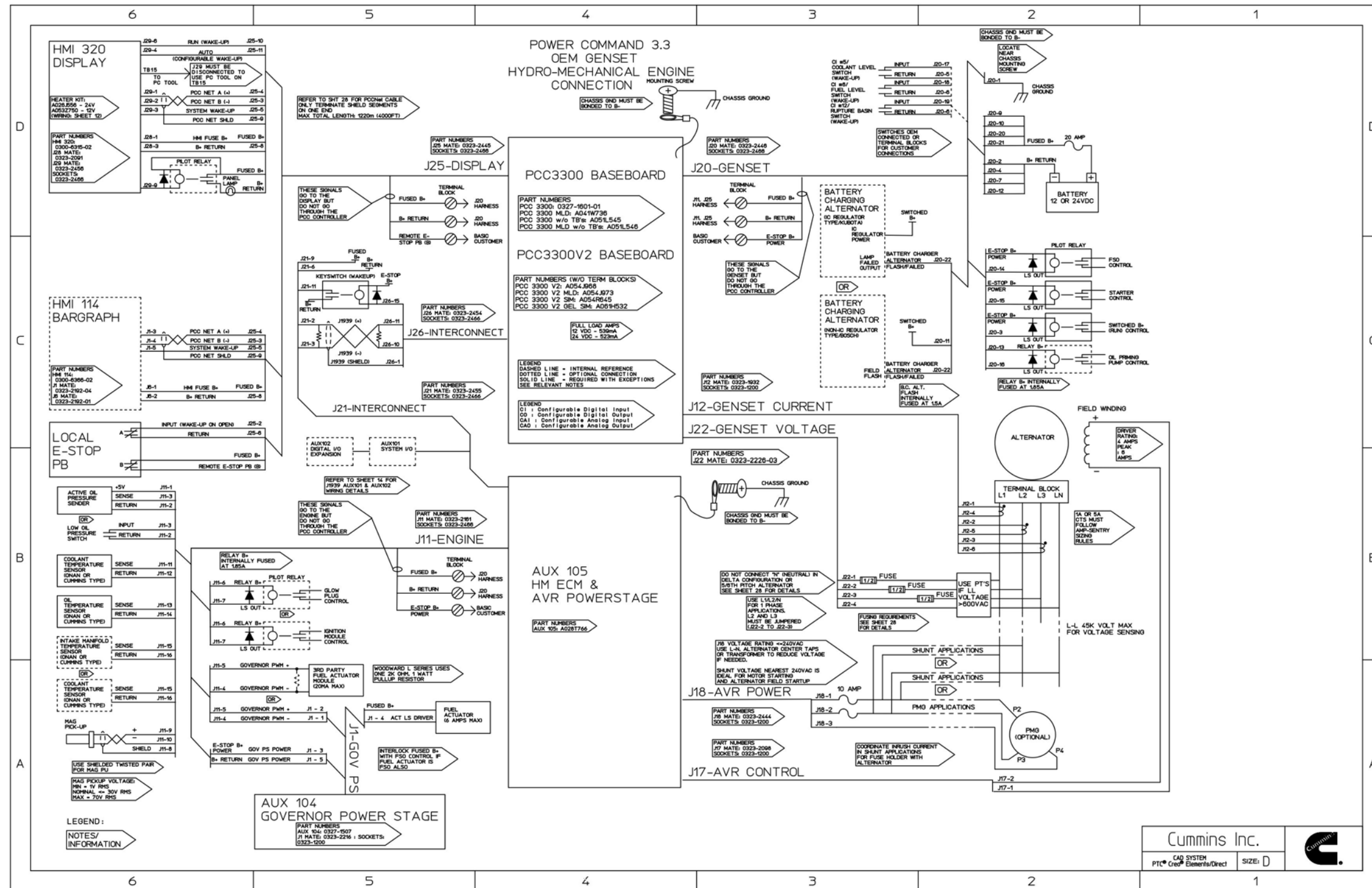

FIGURE 53. POWERCOMMAND 3.3 CONNECTIONS - HYDROMECHANICAL ENGINE

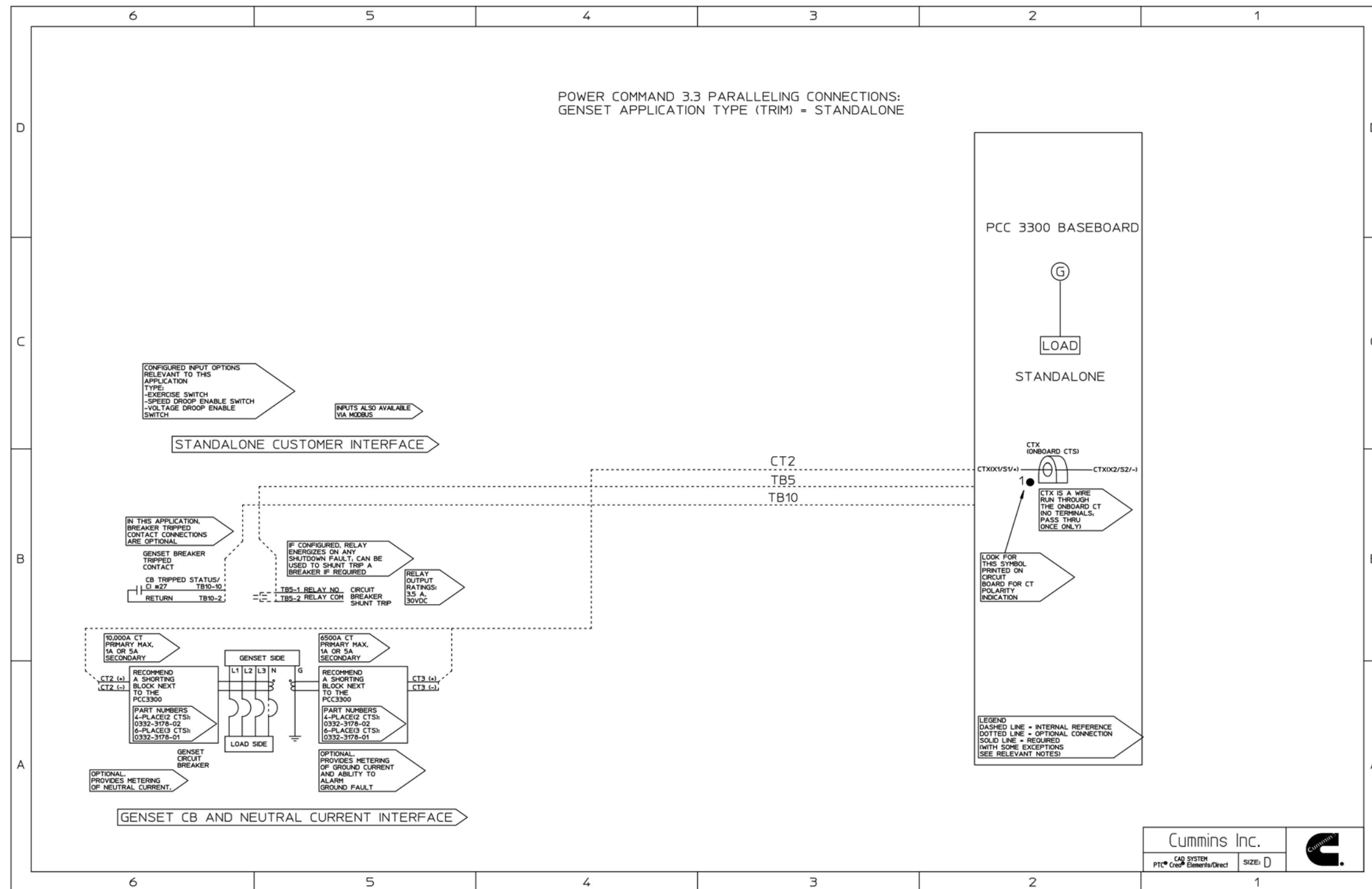
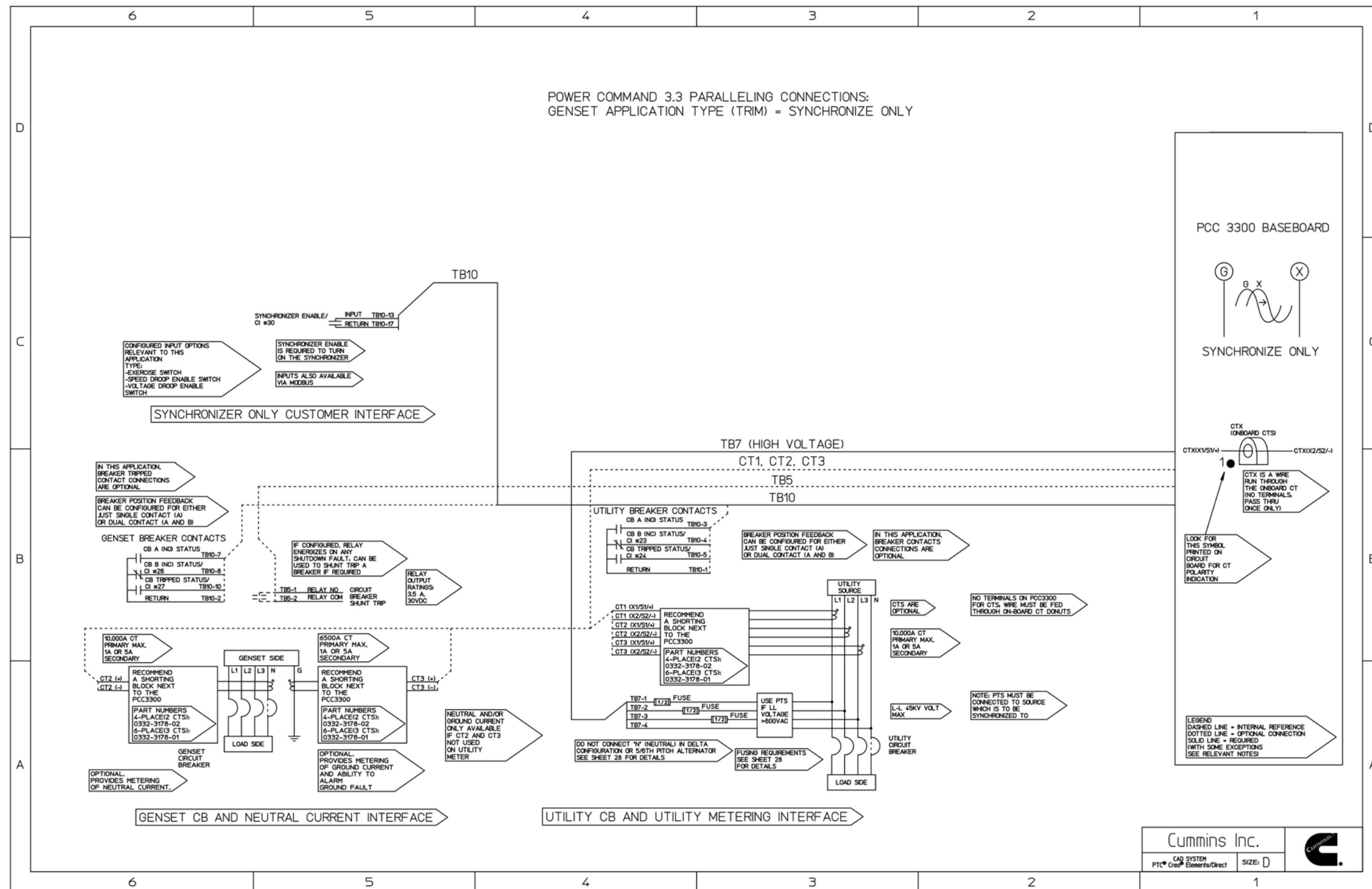
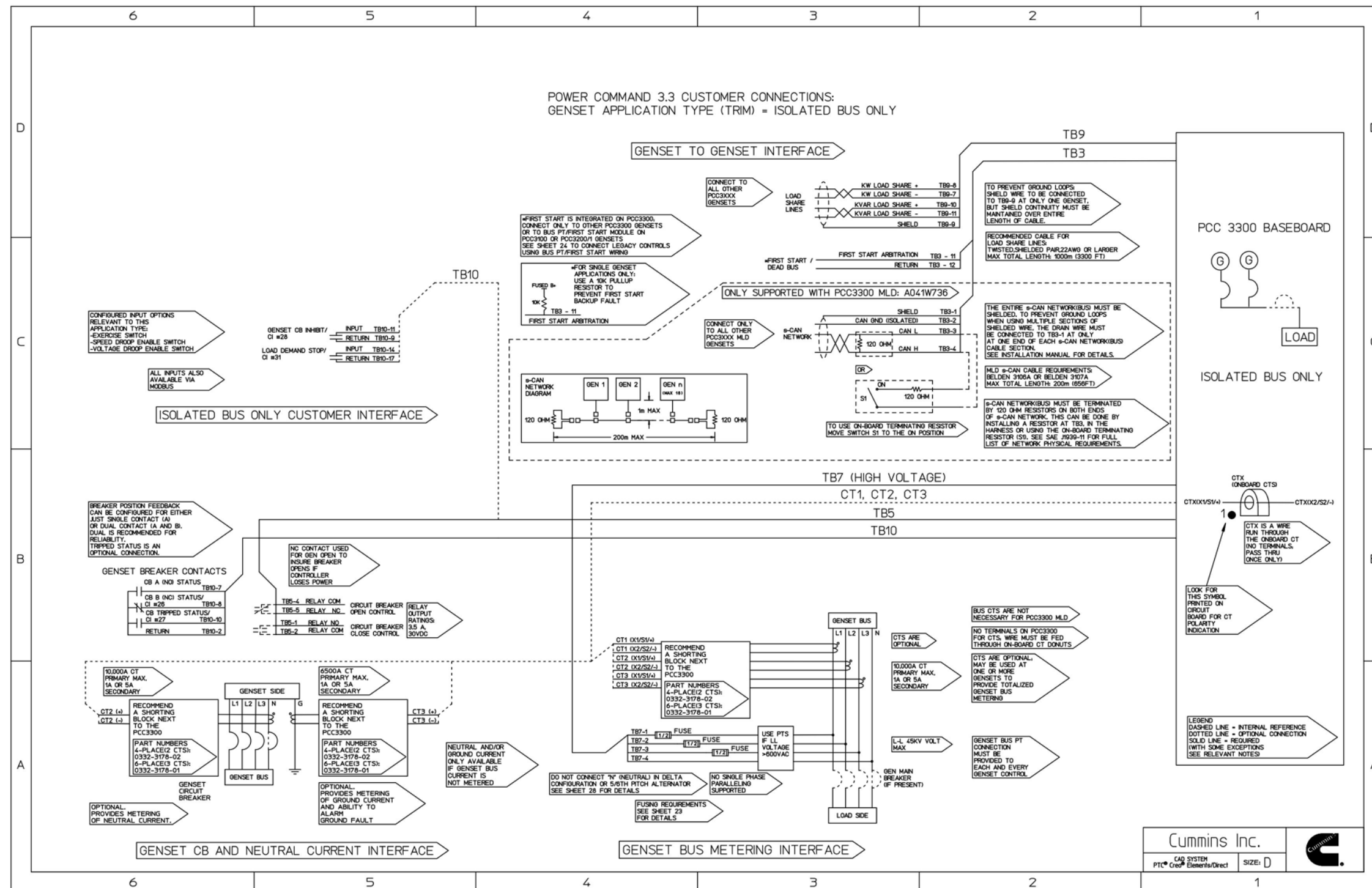

FIGURE 54. POWERCOMMAND 3.3 PARALLELING CONNECTIONS - STANDALONE GENERATOR SET





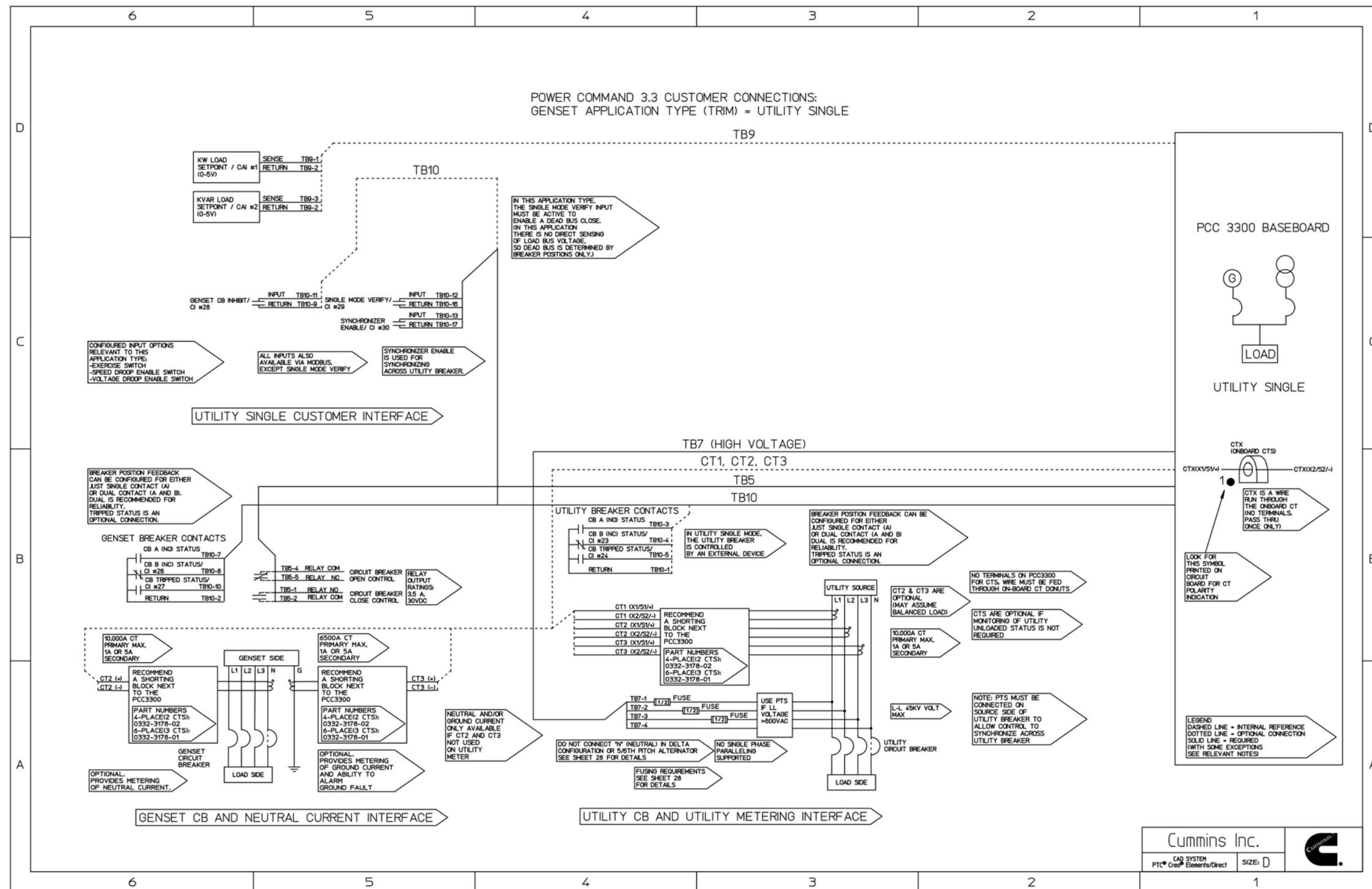

FIGURE 57. POWERCOMMAND 3.3 PARALLELING CONNECTIONS - UTILITY SINGLE

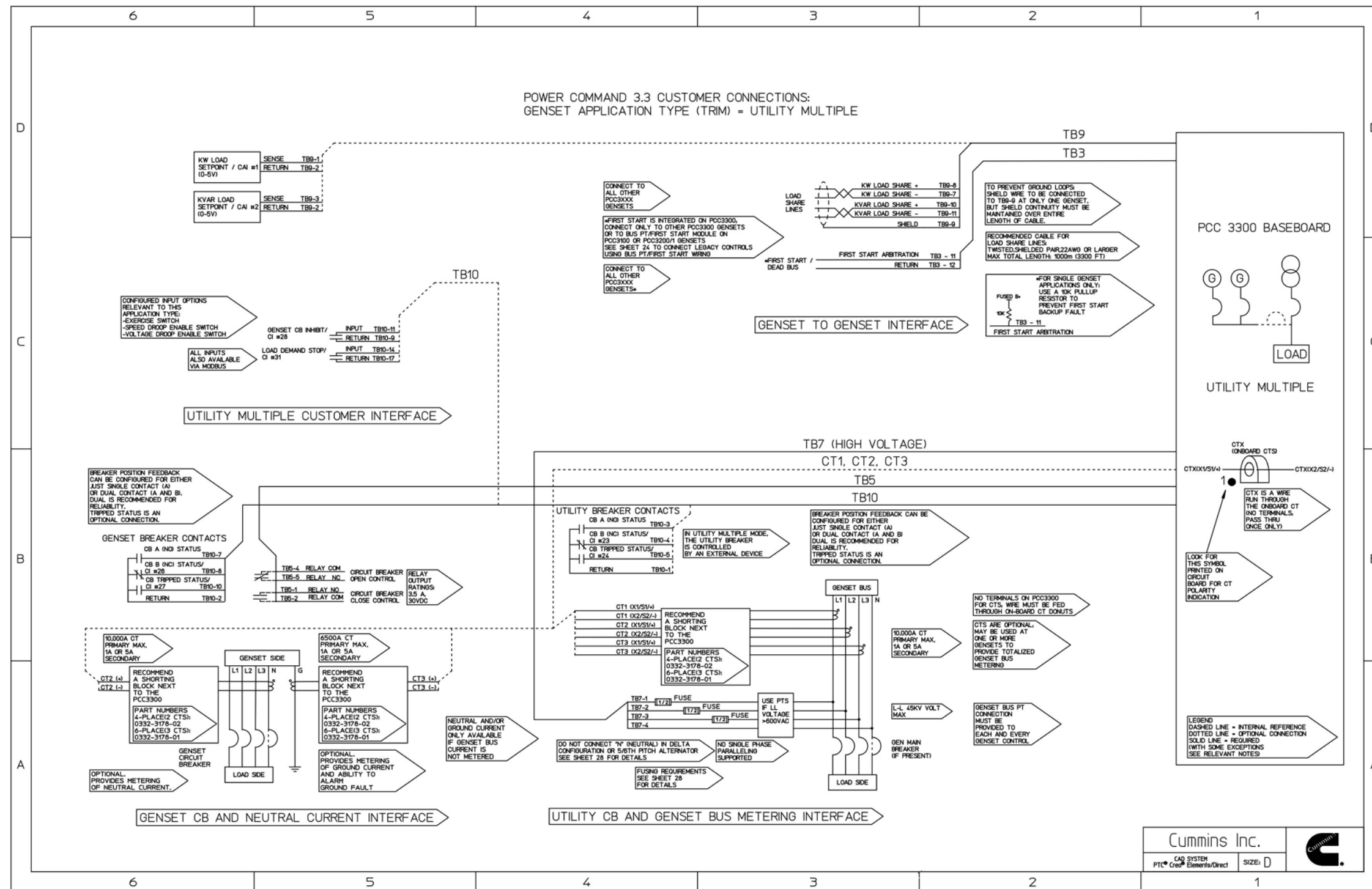

FIGURE 58. POWERCOMMAND 3.3 PARALLELING CONNECTIONS - UTILITY MULTIPLE

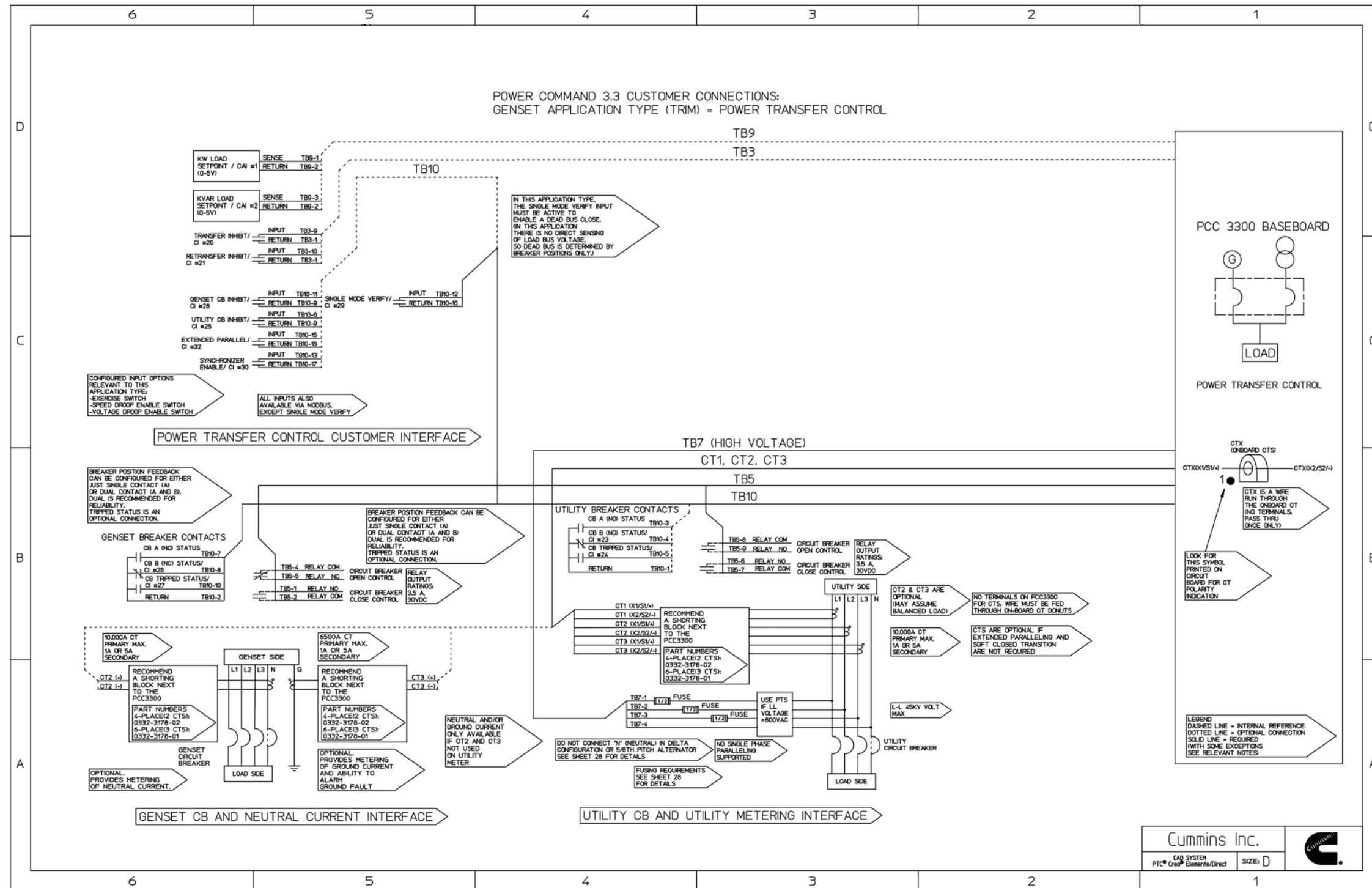

FIGURE 59. POWERCOMMAND 3.3 PARALLELING CONNECTIONS - POWER TRANSFER CONTROL

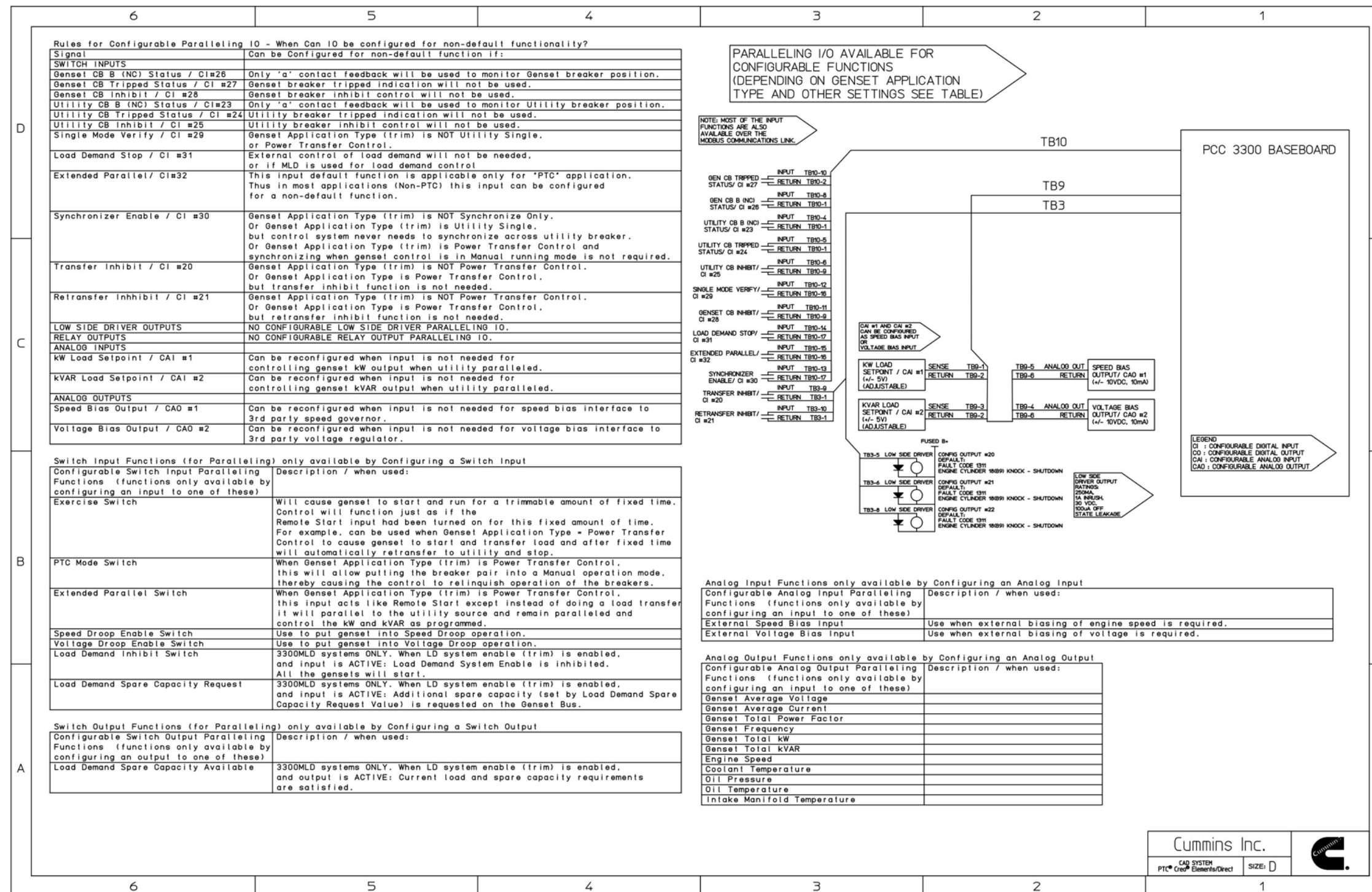

FIGURE 60. POWERCOMMAND 3.3 PARALLELING CONNECTIONS - CONFIGURABLE PARALLELING I/O

This page is intentionally blank.

Appendix C. Outline Drawings

Table of Contents

- Figure 61. Generator Set Outline Drawing (Bearward Set Mounted Radiator) (Sheet 1) 127
- Figure 62. Generator Set Outline Drawing (Bearward Set Mounted Radiator) (Sheet 2) 128
- Figure 63. Generator Set Outline Drawing (Bearward Set Mounted Radiator) (Sheet 3) 129
- Figure 64. Generator Set Outline Drawing (Bearward Set Mounted Radiator) (Sheet 4) 130
- Figure 65. Generator Set Outline Drawing (AKG Set Mounted Radiator) (Sheet 1) 131
- Figure 66. Generator Set Outline Drawing (AKG Set Mounted Radiator) (Sheet 2) 132
- Figure 67. Generator Set Outline Drawing (AKG Set Mounted Radiator) (Sheet 3) 133
- Figure 68. Generator Set Outline Drawing (AKG Set Mounted Radiator) (Sheet 4) 134
- Figure 69. Generator Set Outline Drawing (Set Mounted Radiator) (Sheet 1) 135
- Figure 70. Generator Set Outline Drawing (Set Mounted Radiator) (Sheet 2) 136
- Figure 71. Generator Set Outline Drawing (Set Mounted Radiator) (Sheet 3) 137
- Figure 72. Generator Set Outline Drawing (Set Mounted Radiator) (Sheet 4) 138
- Figure 73. Generator Set Outline Drawing (Remote Radiator) (Sheet 1) 139
- Figure 74. Generator Set Outline Drawing (Remote Radiator) (Sheet 2) 140
- Figure 75. Generator Set Outline Drawing (Remote Radiator) (Sheet 3) 141
- Figure 76. Generator Set Outline Drawing (Remote Radiator) (Sheet 4) 142
- Figure 77. Generator Set Outline Drawing (Remote Radiator) (Sheet 5) 143
- Figure 78. Generator Set Outline Drawing (Remote Radiator) (Sheet 1) 144
- Figure 79. Generator Set Outline Drawing (Remote Radiator) (Sheet 2) 145
- Figure 80. Generator Set Outline Drawing (Remote Radiator) (Sheet 3) 146
- Figure 81. Generator Set Outline Drawing (Remote Radiator) (Sheet 4) 147

The drawings included in this section are representative. For current complete information, refer to the drawing package that was shipped with the unit.

C.1 Generator Set Outline Drawing (A053G789) - Set Mounted Radiator

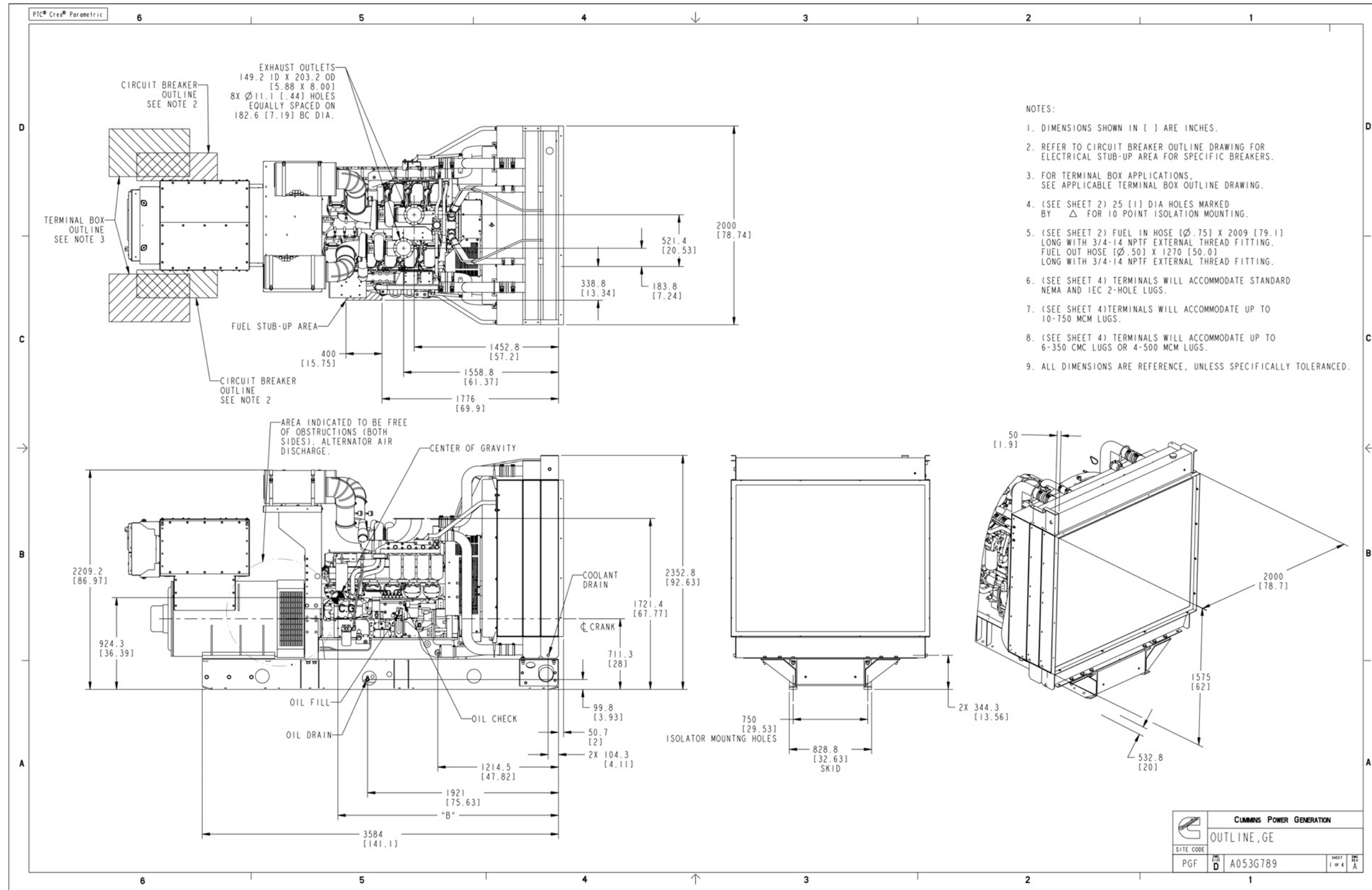

FIGURE 61. GENERATOR SET OUTLINE DRAWING (BEARWARD SET MOUNTED RADIATOR) (SHEET 1)

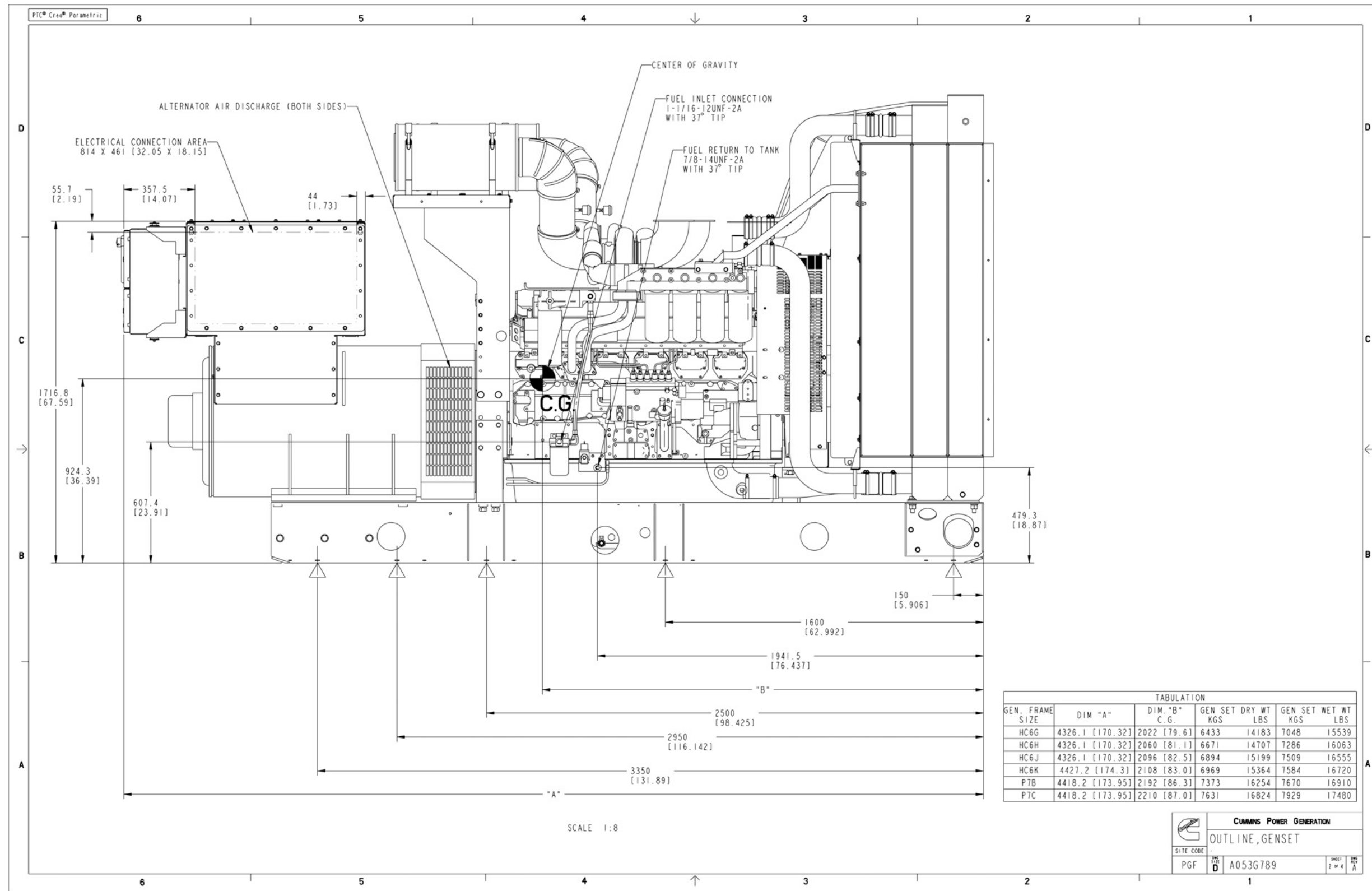

FIGURE 62. GENERATOR SET OUTLINE DRAWING (BEARWARD SET MOUNTED RADIATOR) (SHEET 2)

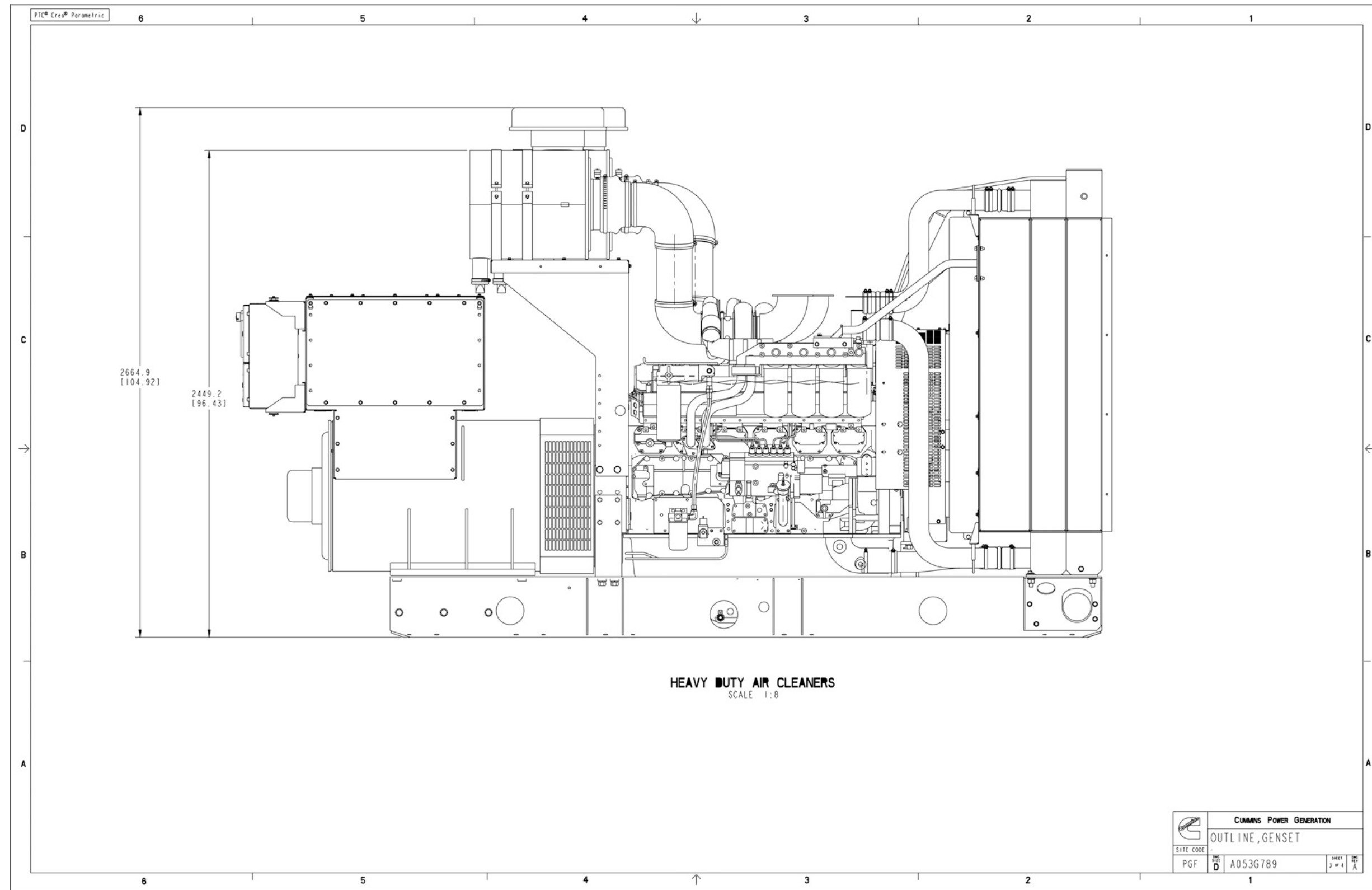

FIGURE 63. GENERATOR SET OUTLINE DRAWING (BEARWARD SET MOUNTED RADIATOR) (SHEET 3)

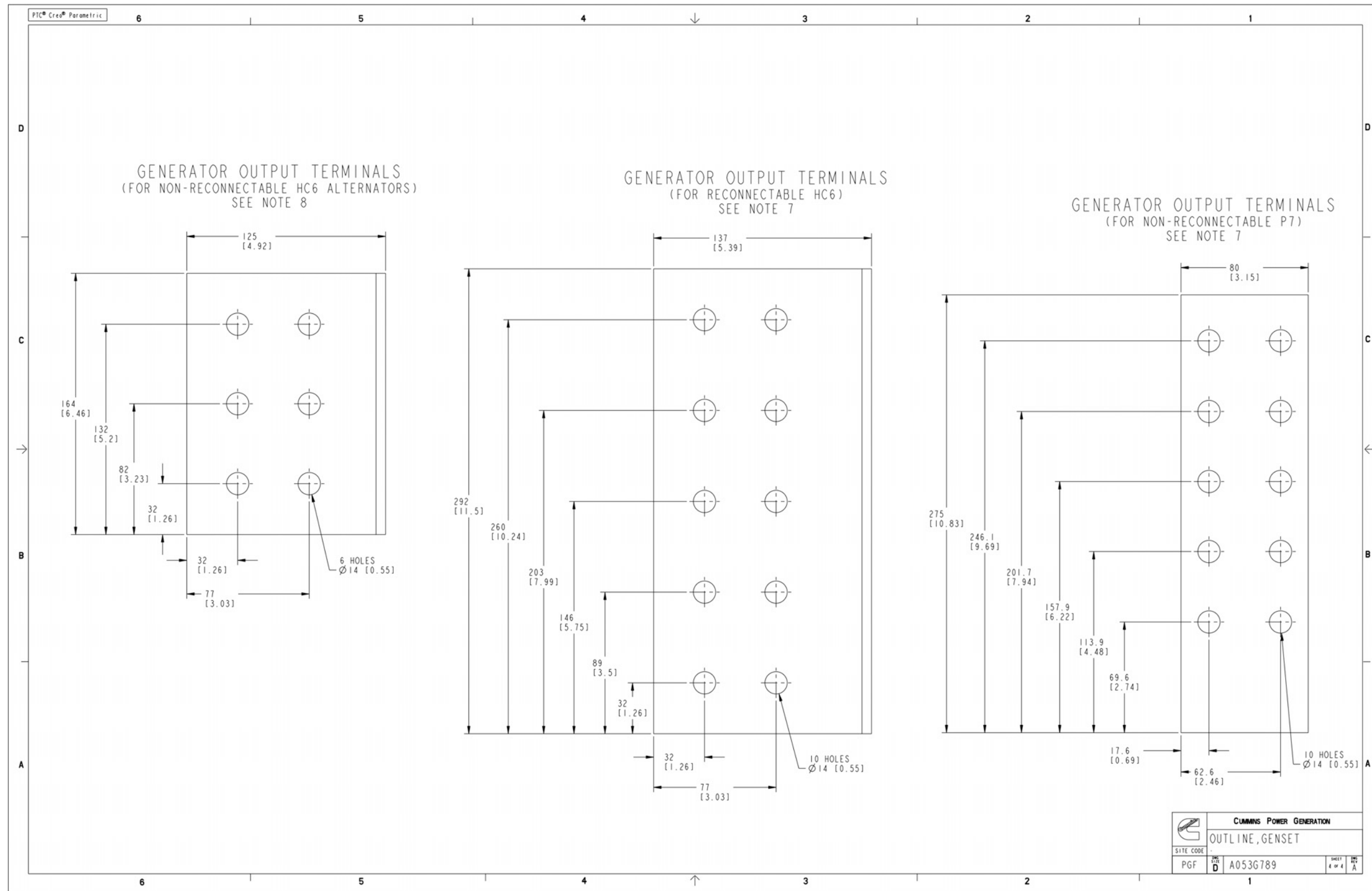
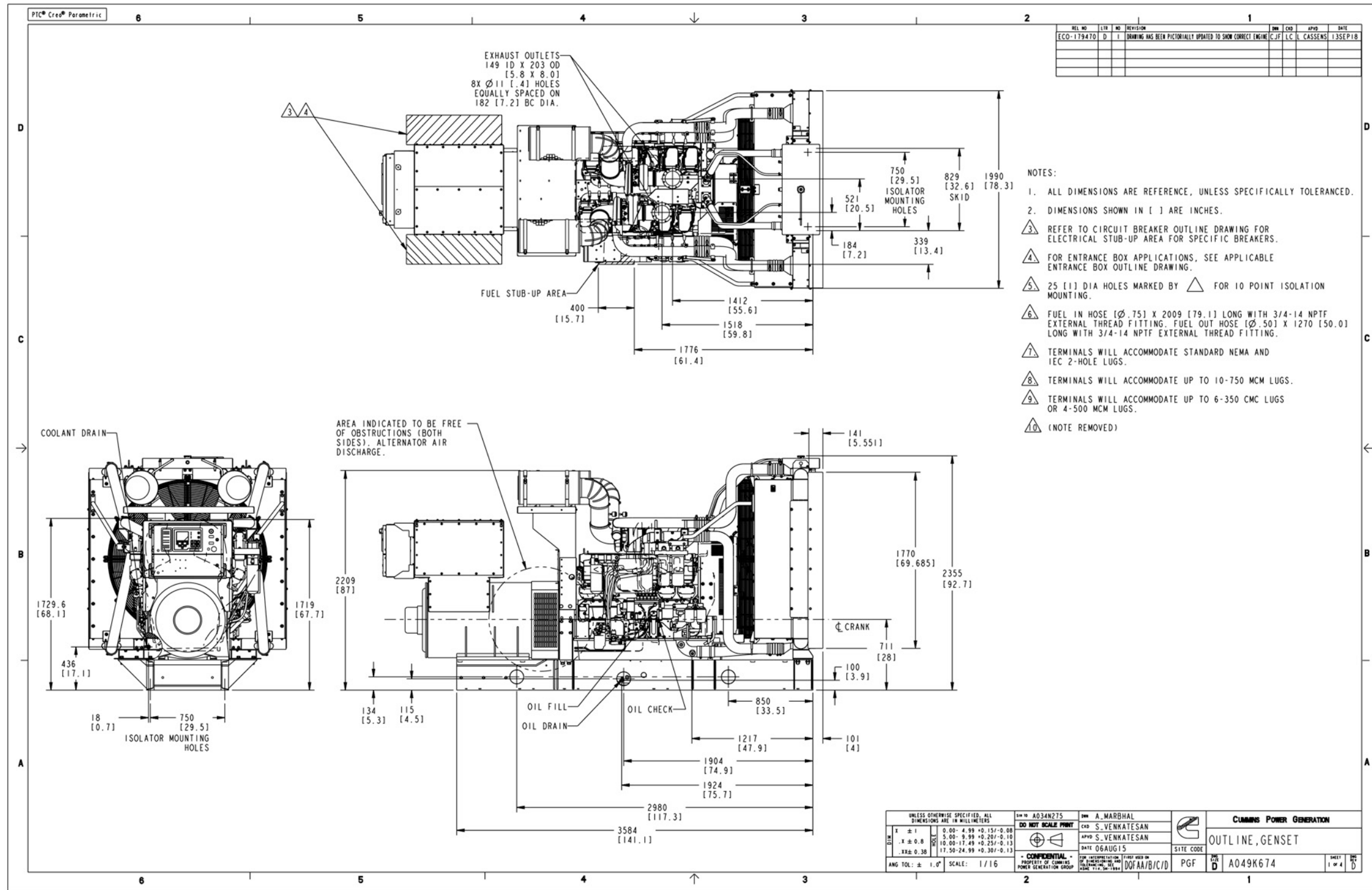

FIGURE 64. GENERATOR SET OUTLINE DRAWING (BEARWARD SET MOUNTED RADIATOR) (SHEET 4)

C.2 Generator Set Outline Drawing (A049K674) - Set Mounted Radiator



Drawing Name: A049K675 Revision: D
Part Name: A049K674 Revision: D

FIGURE 65. GENERATOR SET OUTLINE DRAWING (AKG SET MOUNTED RADIATOR) (SHEET 1)

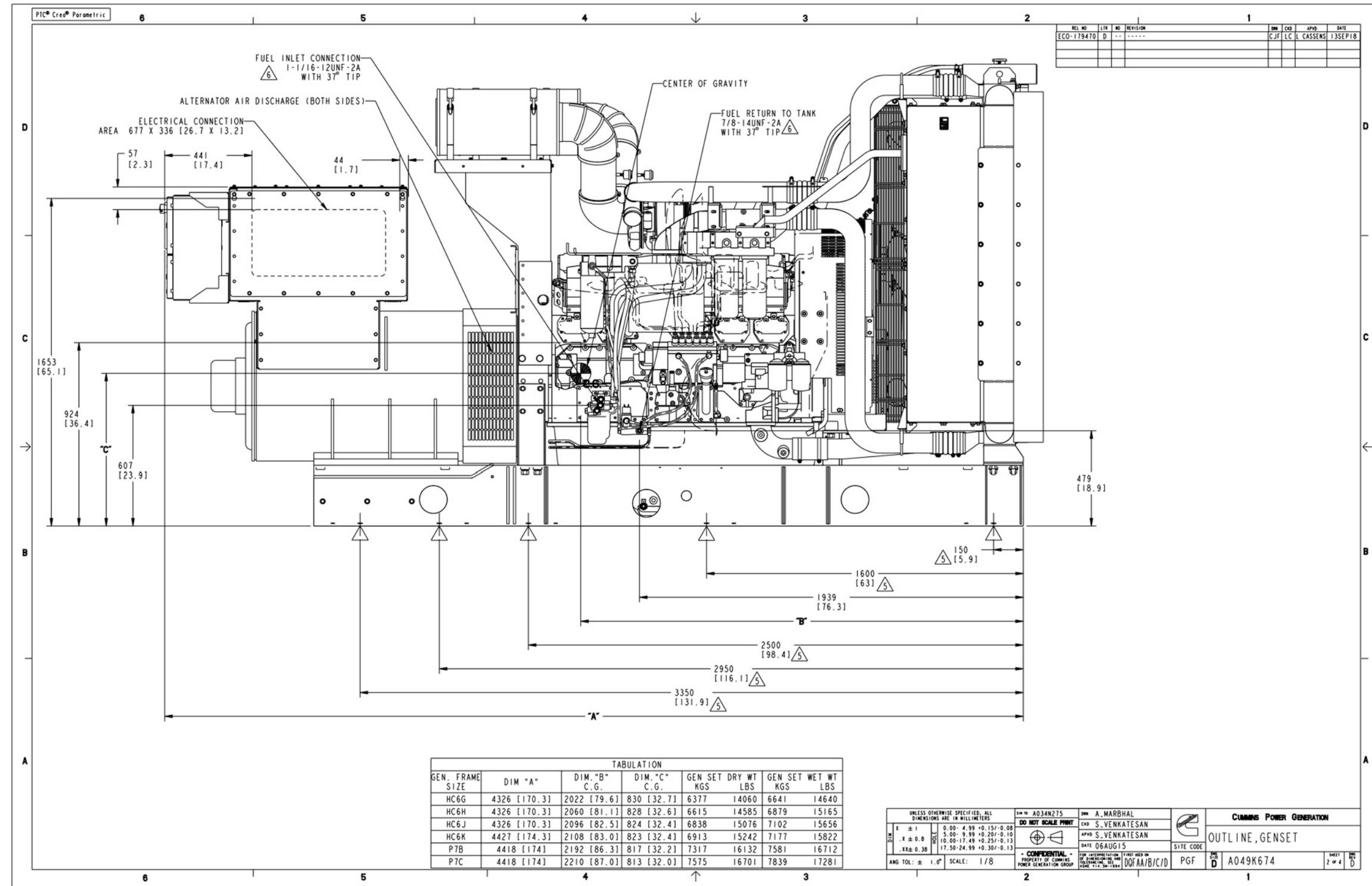

Drawing Name: A049K675 Revision: D
Part Name: A049K674 Revision: D

FIGURE 66. GENERATOR SET OUTLINE DRAWING (AKG SET MOUNTED RADIATOR) (SHEET 2)

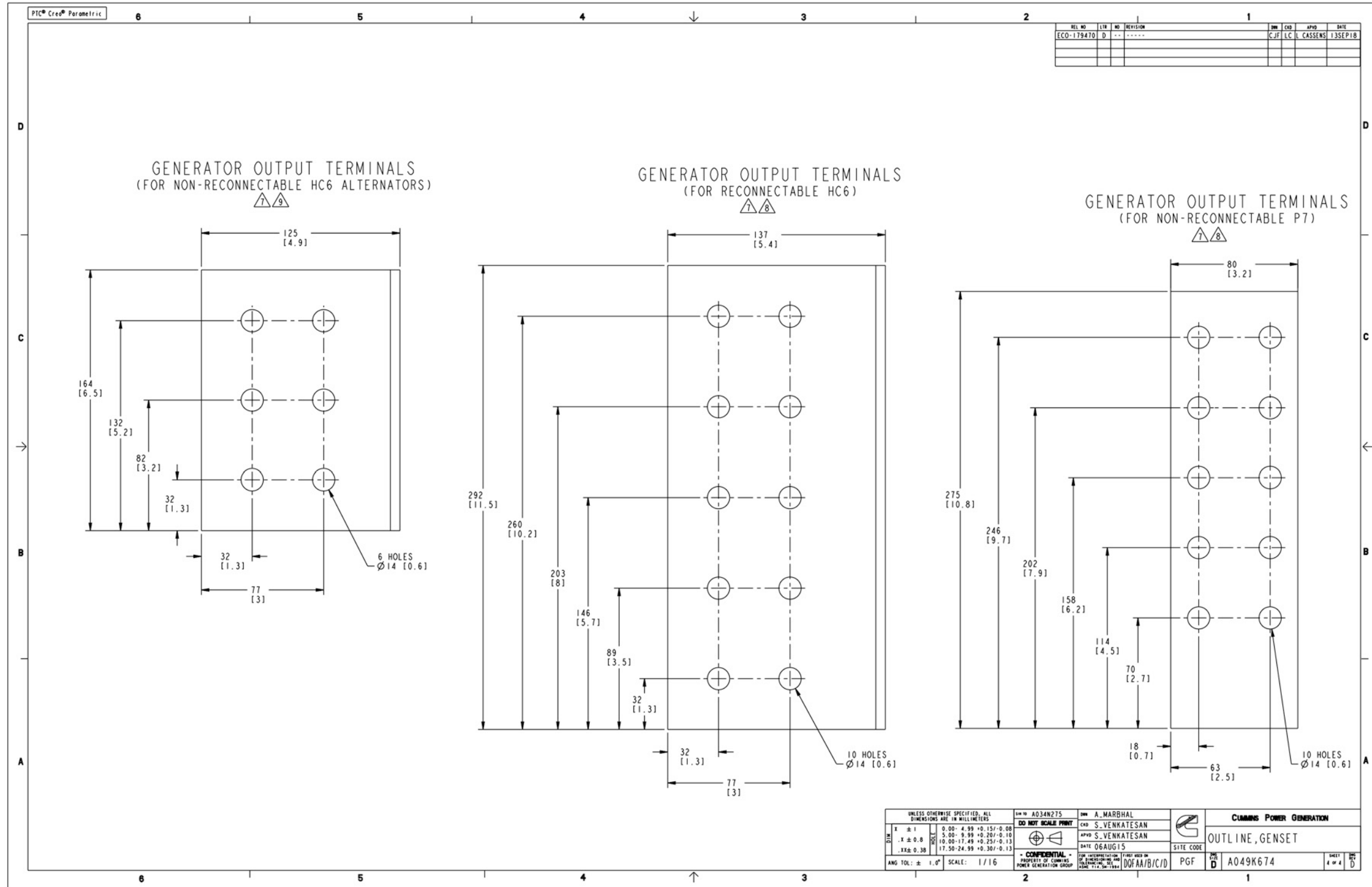

Drawing Name: A049K675 Revision: D
Part Name: A049K674 Revision: D

FIGURE 68. GENERATOR SET OUTLINE DRAWING (AKG SET MOUNTED RADIATOR) (SHEET 4)

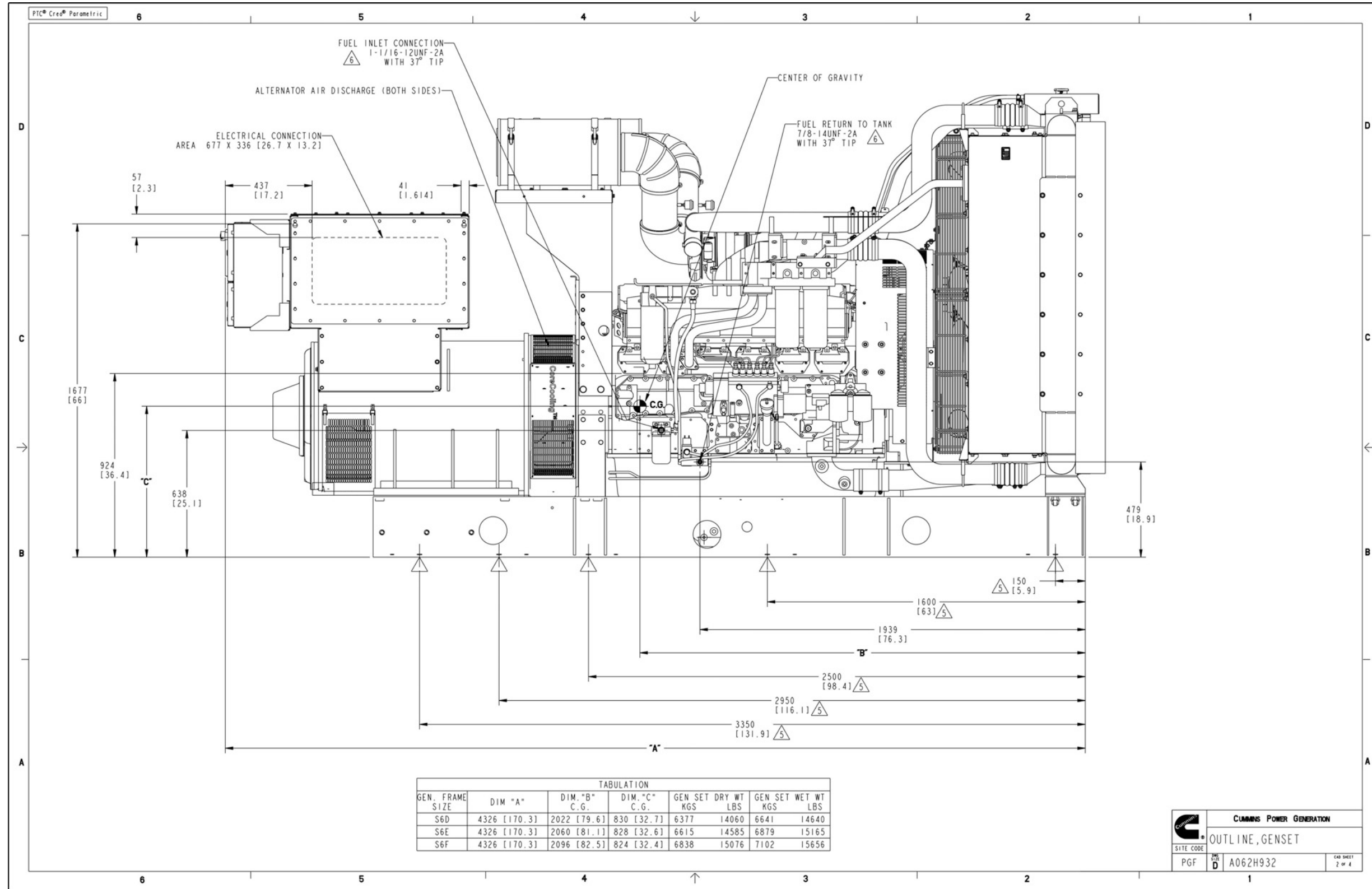

FIGURE 70. GENERATOR SET OUTLINE DRAWING (SET MOUNTED RADIATOR) (SHEET 2)

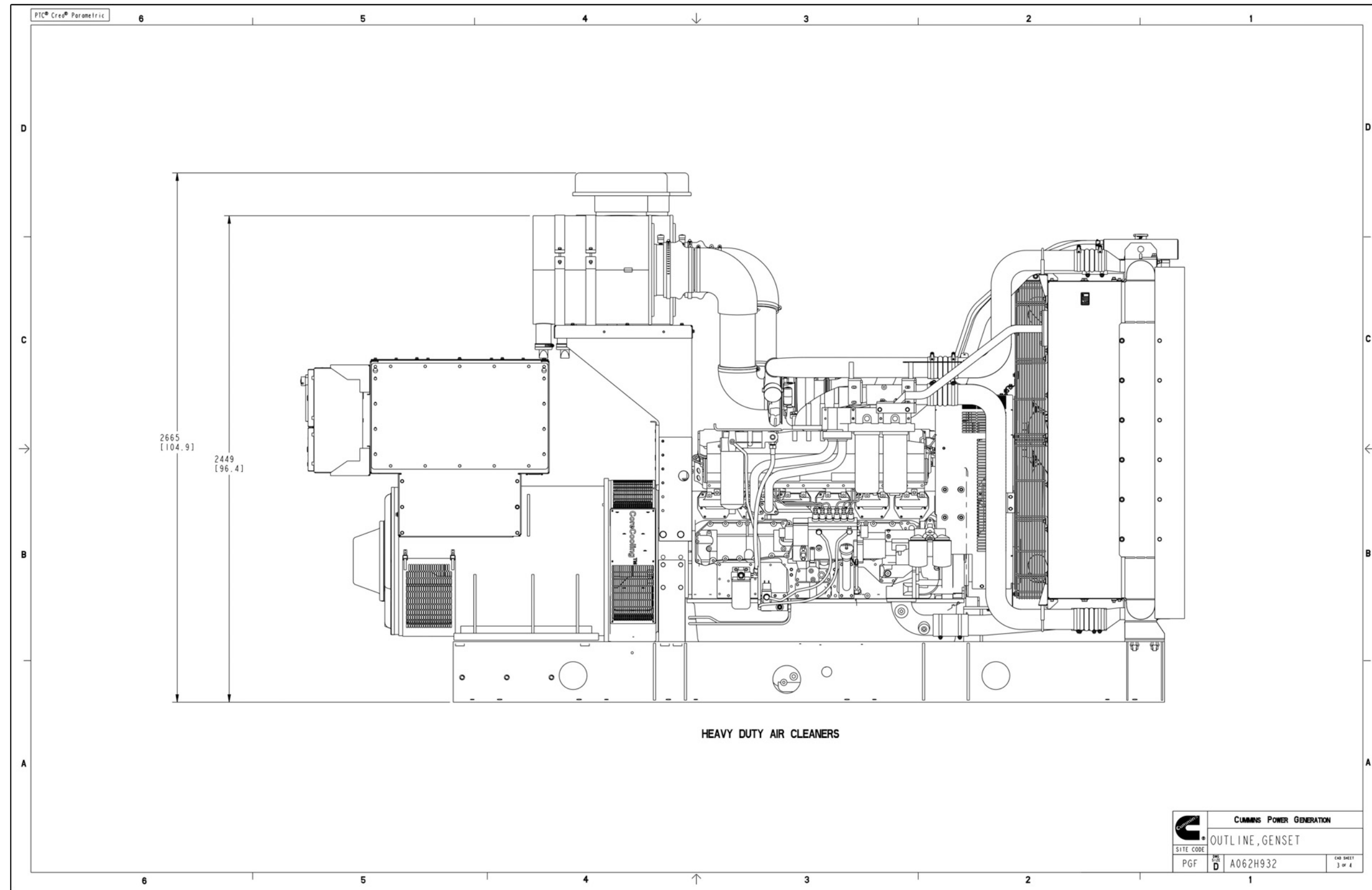

FIGURE 71. GENERATOR SET OUTLINE DRAWING (SET MOUNTED RADIATOR) (SHEET 3)

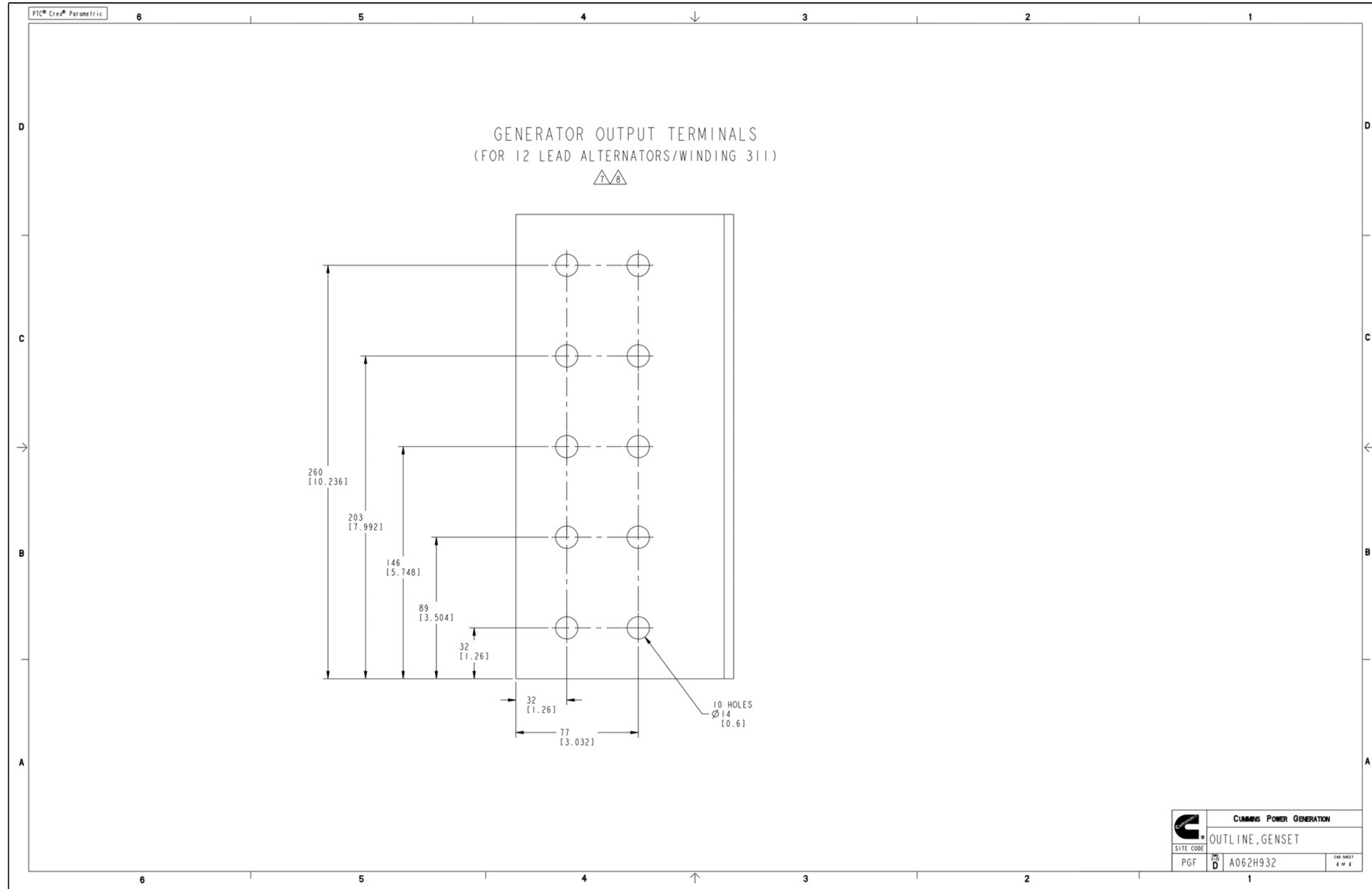

FIGURE 72. GENERATOR SET OUTLINE DRAWING (SET MOUNTED RADIATOR) (SHEET 4)

C.4 Generator Set Outline Drawing (A053G787) - Remote Radiator

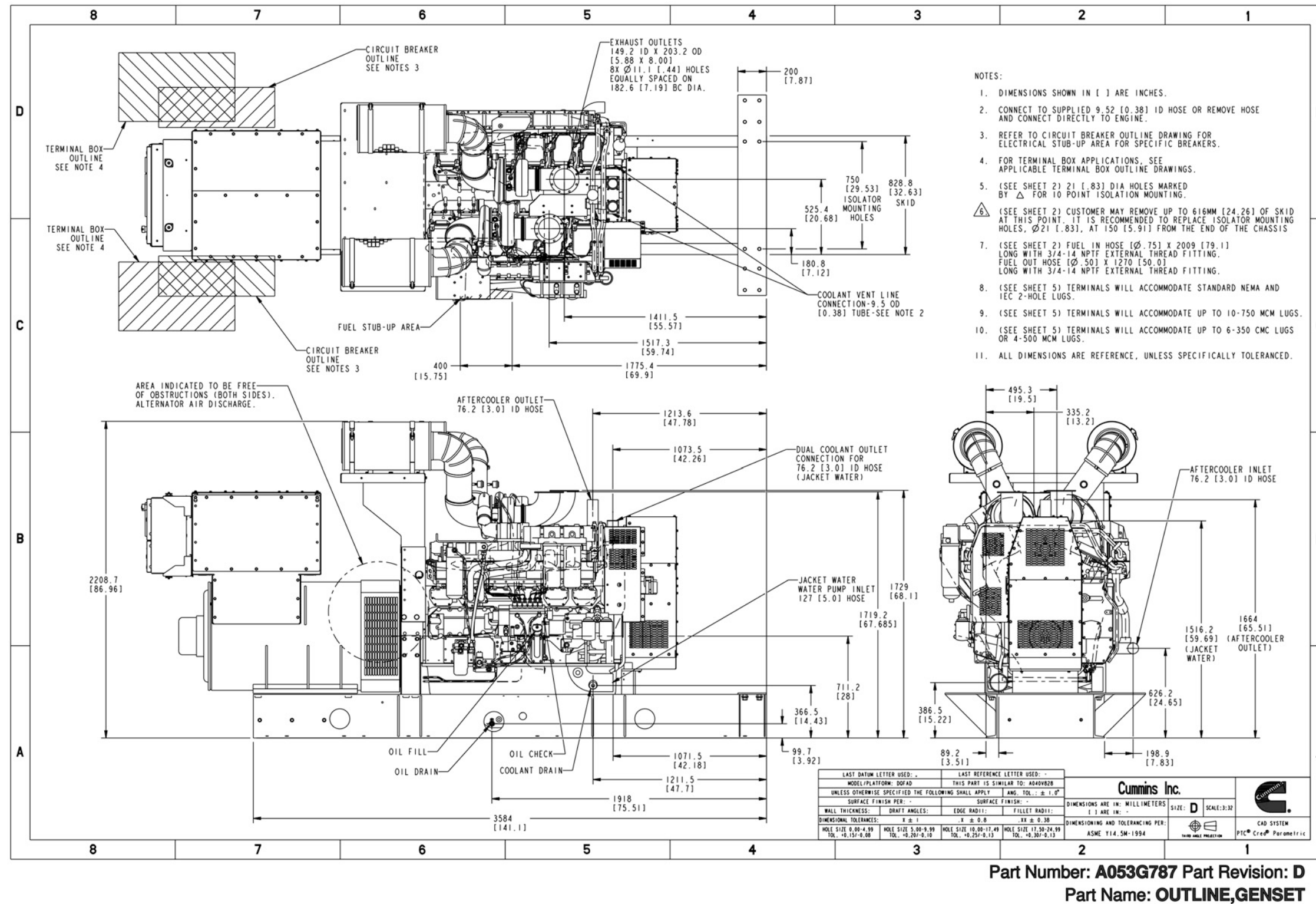

FIGURE 73. GENERATOR SET OUTLINE DRAWING (REMOTE RADIATOR) (SHEET 1)

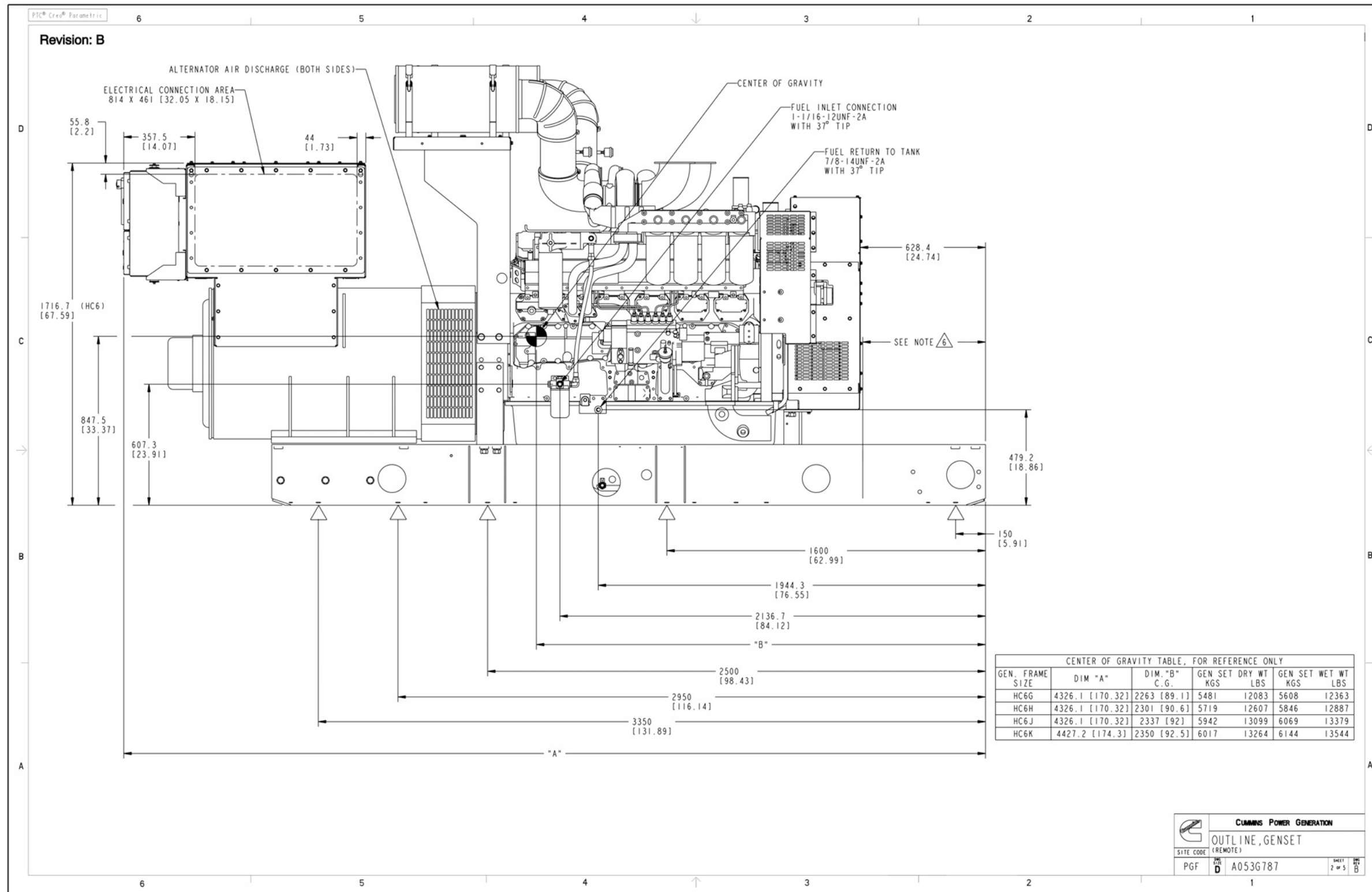
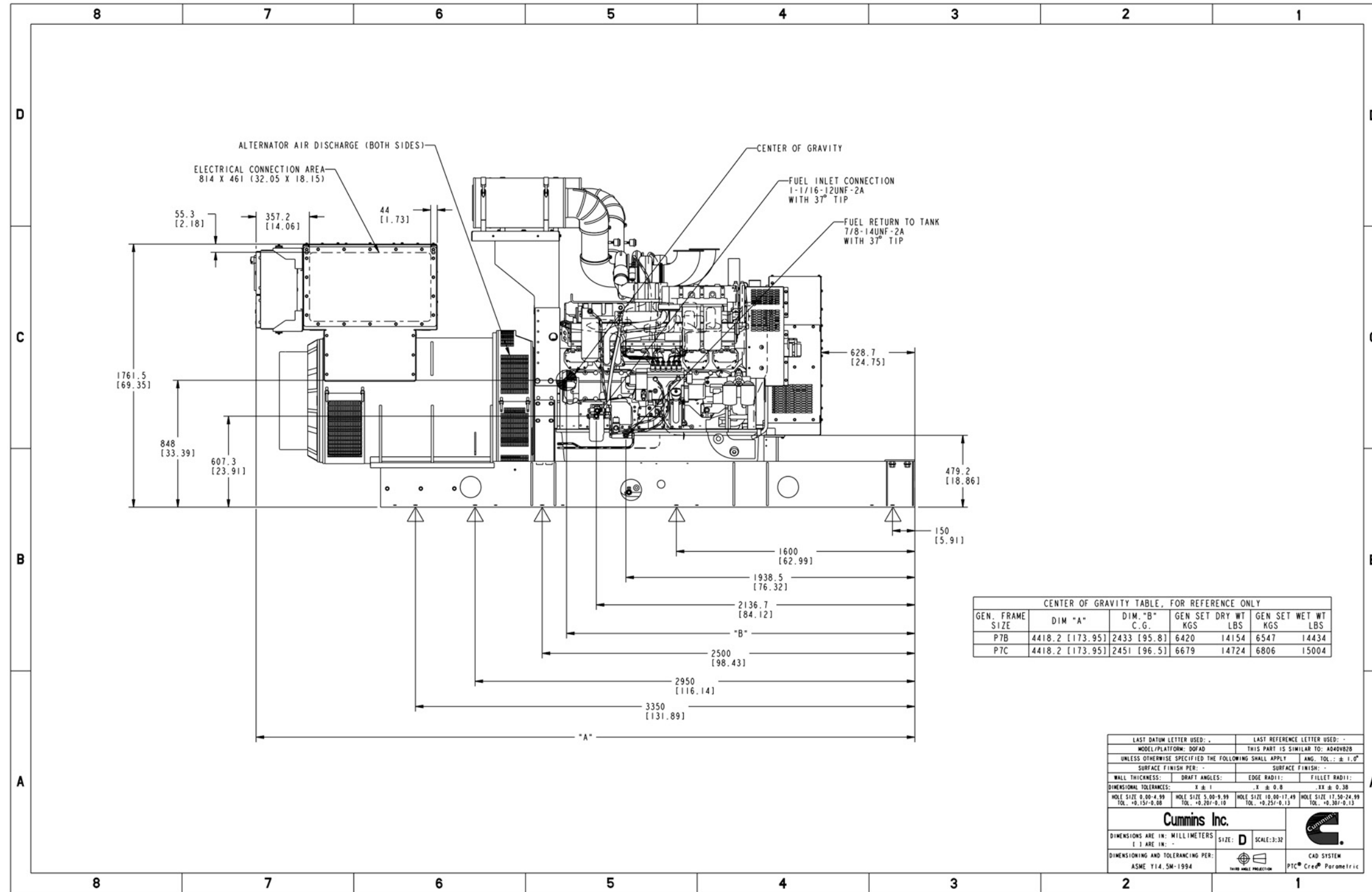

FIGURE 74. GENERATOR SET OUTLINE DRAWING (REMOTE RADIATOR) (SHEET 2)



Part Number: **A053G787** Part Revision: **D**
Part Name: **OUTLINE,GENSET**

FIGURE 75. GENERATOR SET OUTLINE DRAWING (REMOTE RADIATOR) (SHEET 3)

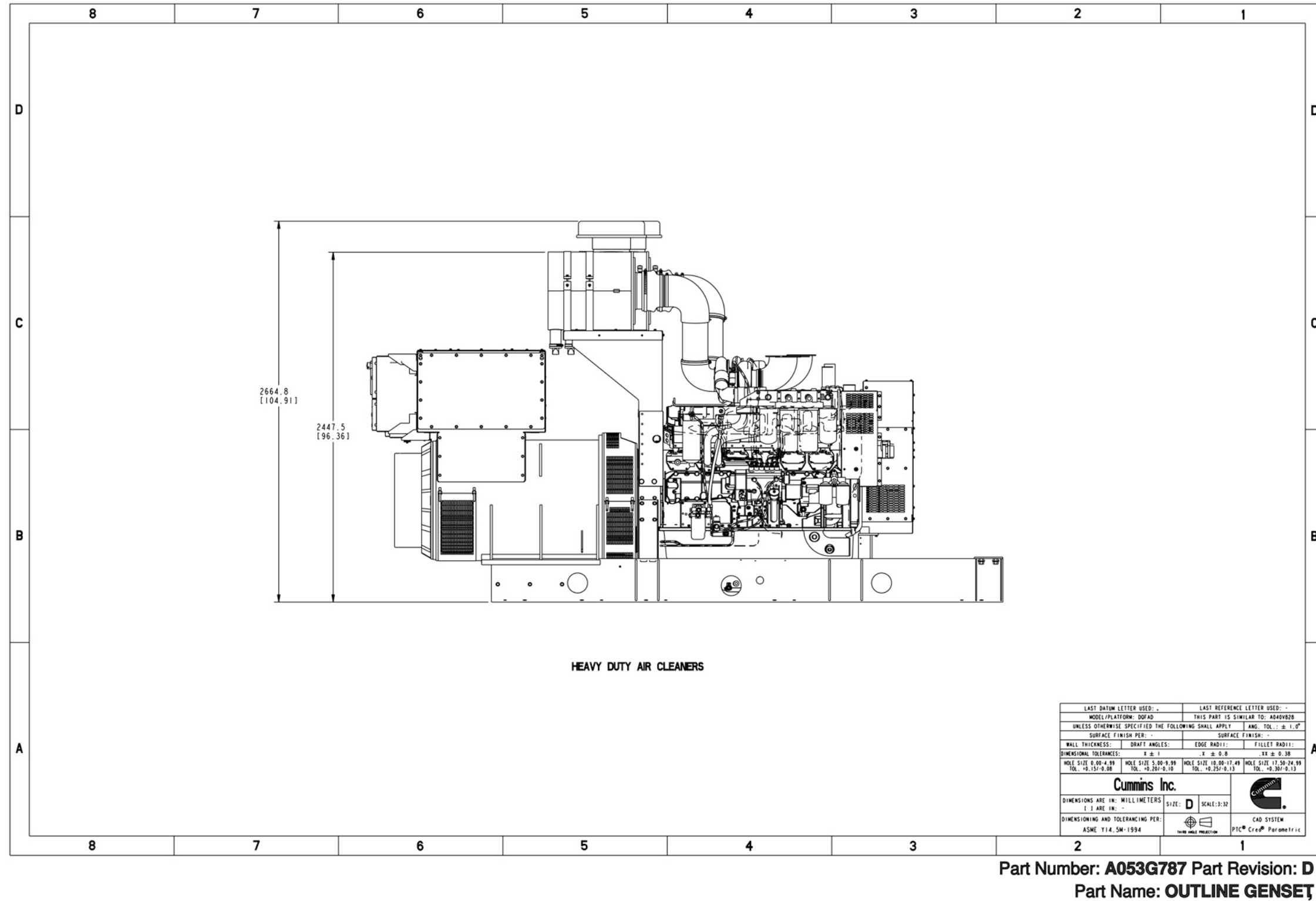
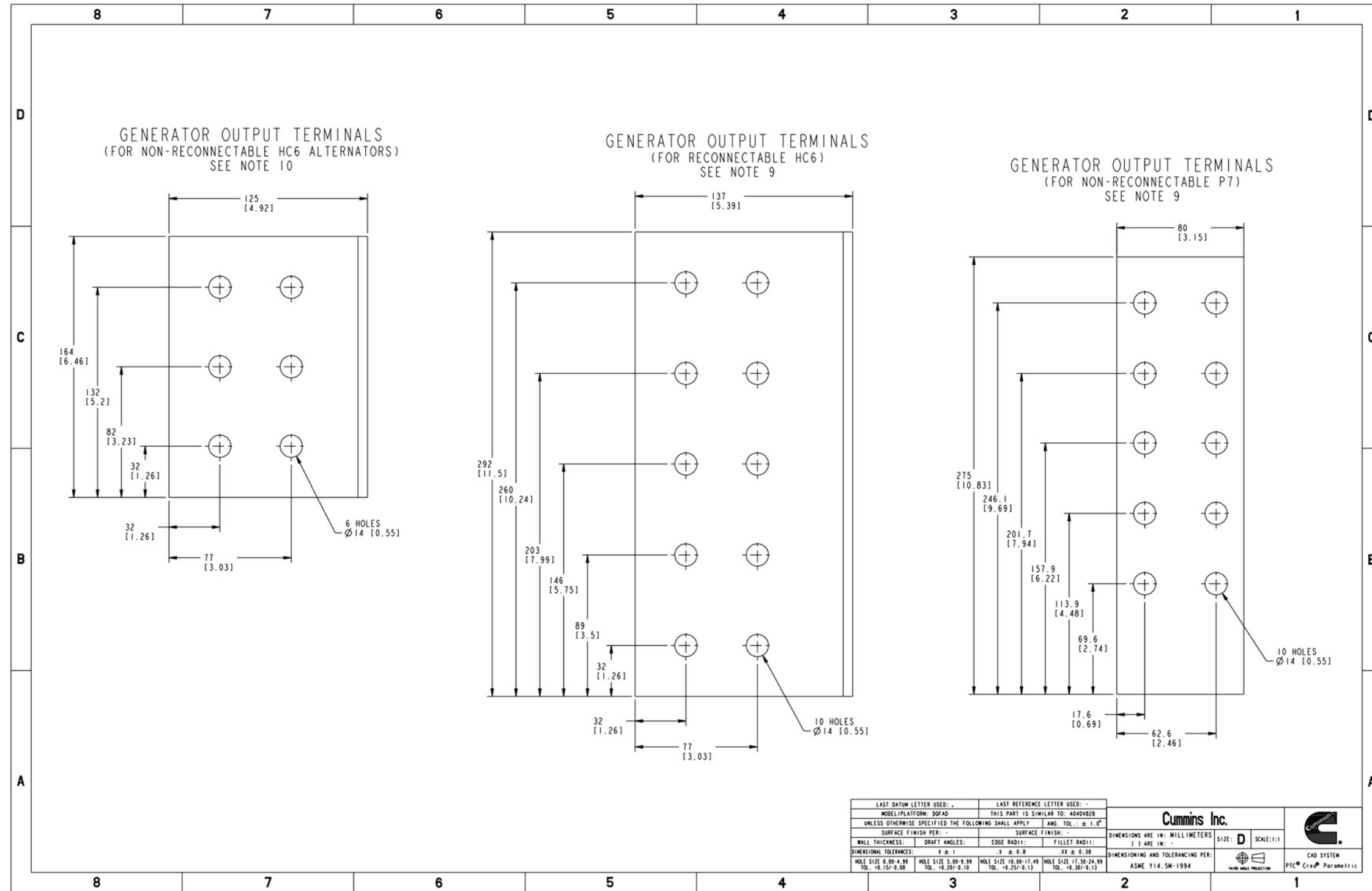

FIGURE 76. GENERATOR SET OUTLINE DRAWING (REMOTE RADIATOR) (SHEET 4)



Part Number: A053G787 Part Revision: D
Part Name: OUTLINE,GENSET

FIGURE 77. GENERATOR SET OUTLINE DRAWING (REMOTE RADIATOR) (SHEET 5)

C.5 Generator Set Outline Drawing (A062M281) - Remote Radiator

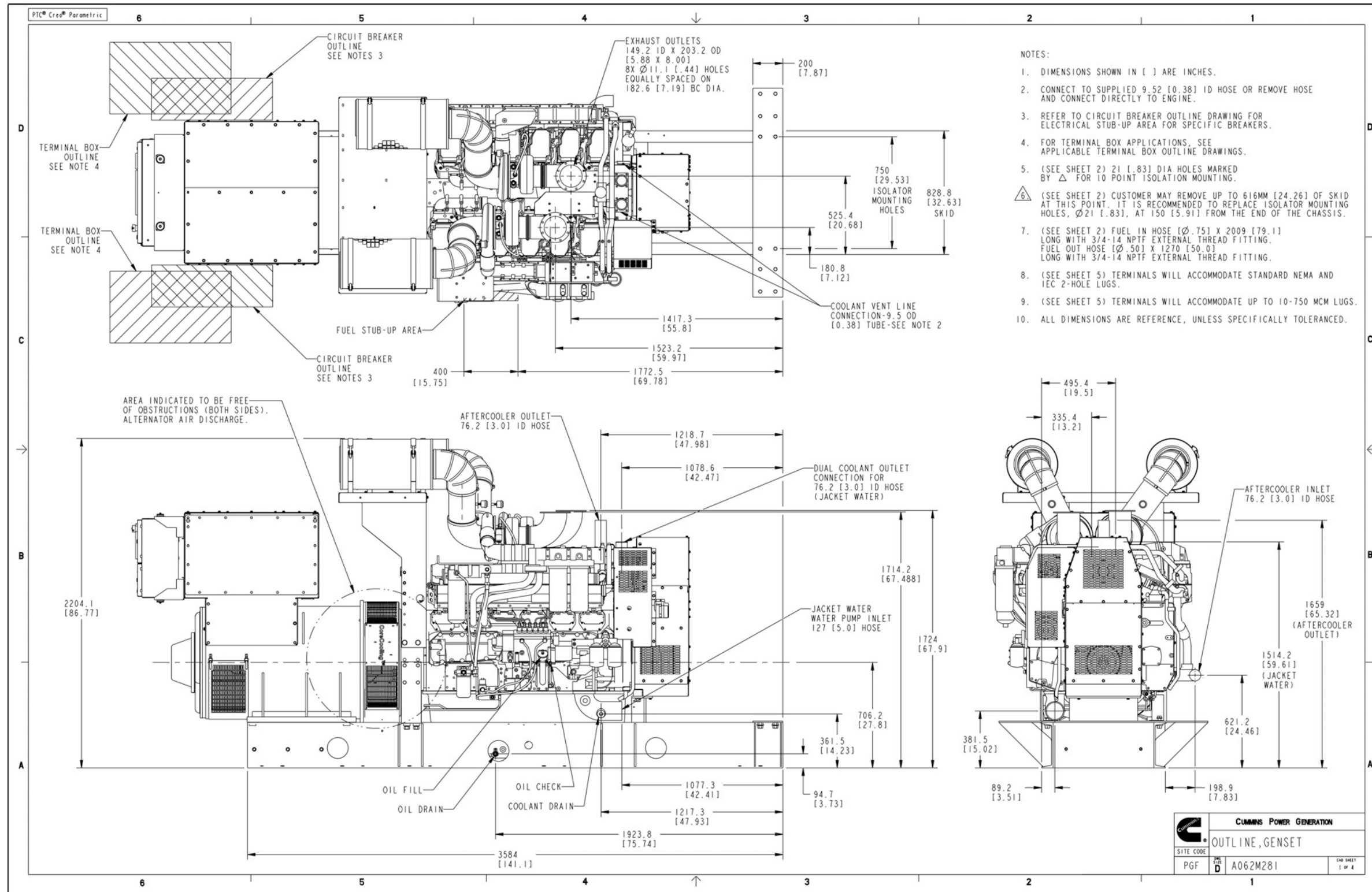

FIGURE 78. GENERATOR SET OUTLINE DRAWING (REMOTE RADIATOR) (SHEET 1)

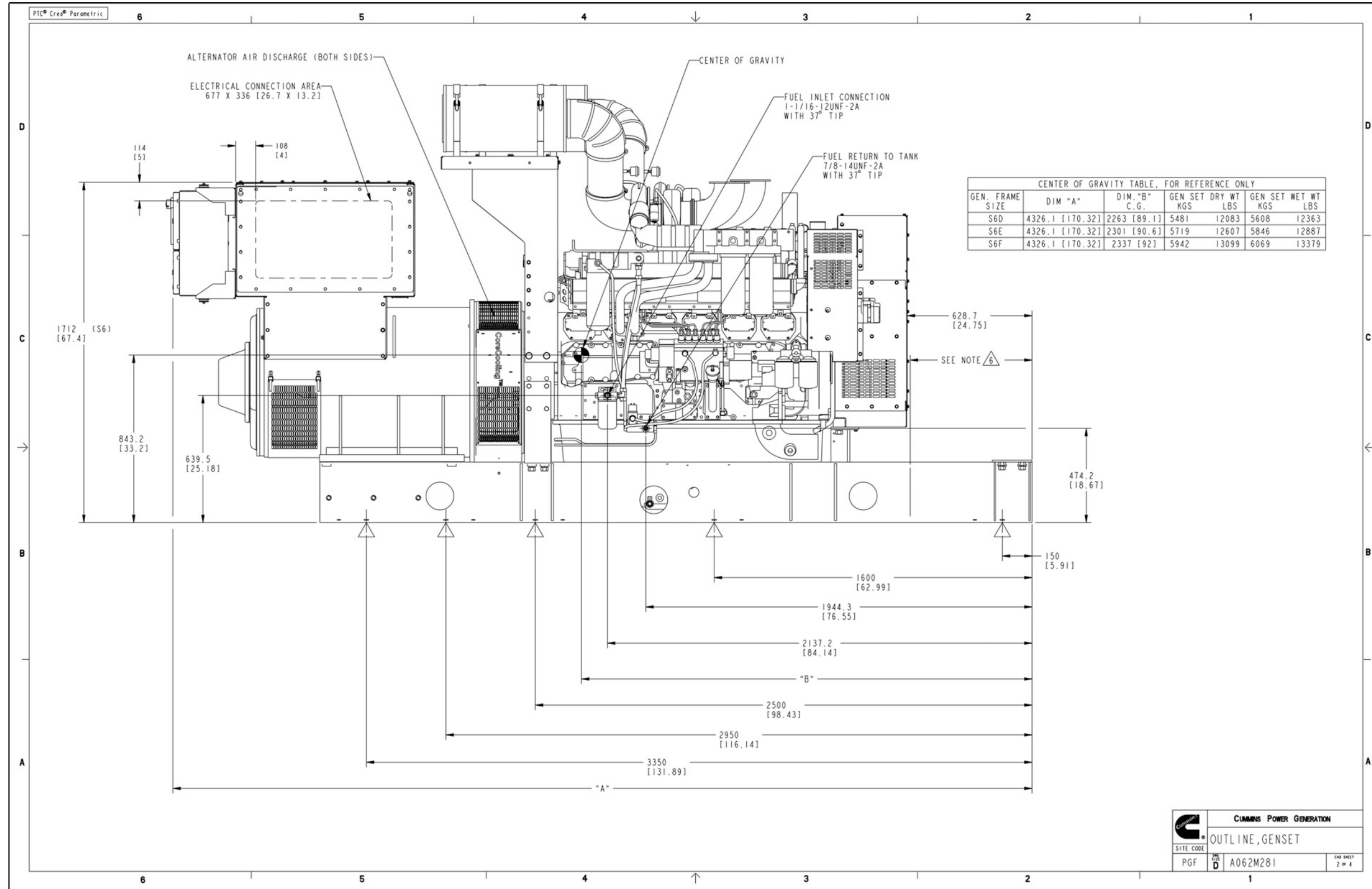

FIGURE 79. GENERATOR SET OUTLINE DRAWING (REMOTE RADIATOR) (SHEET 2)

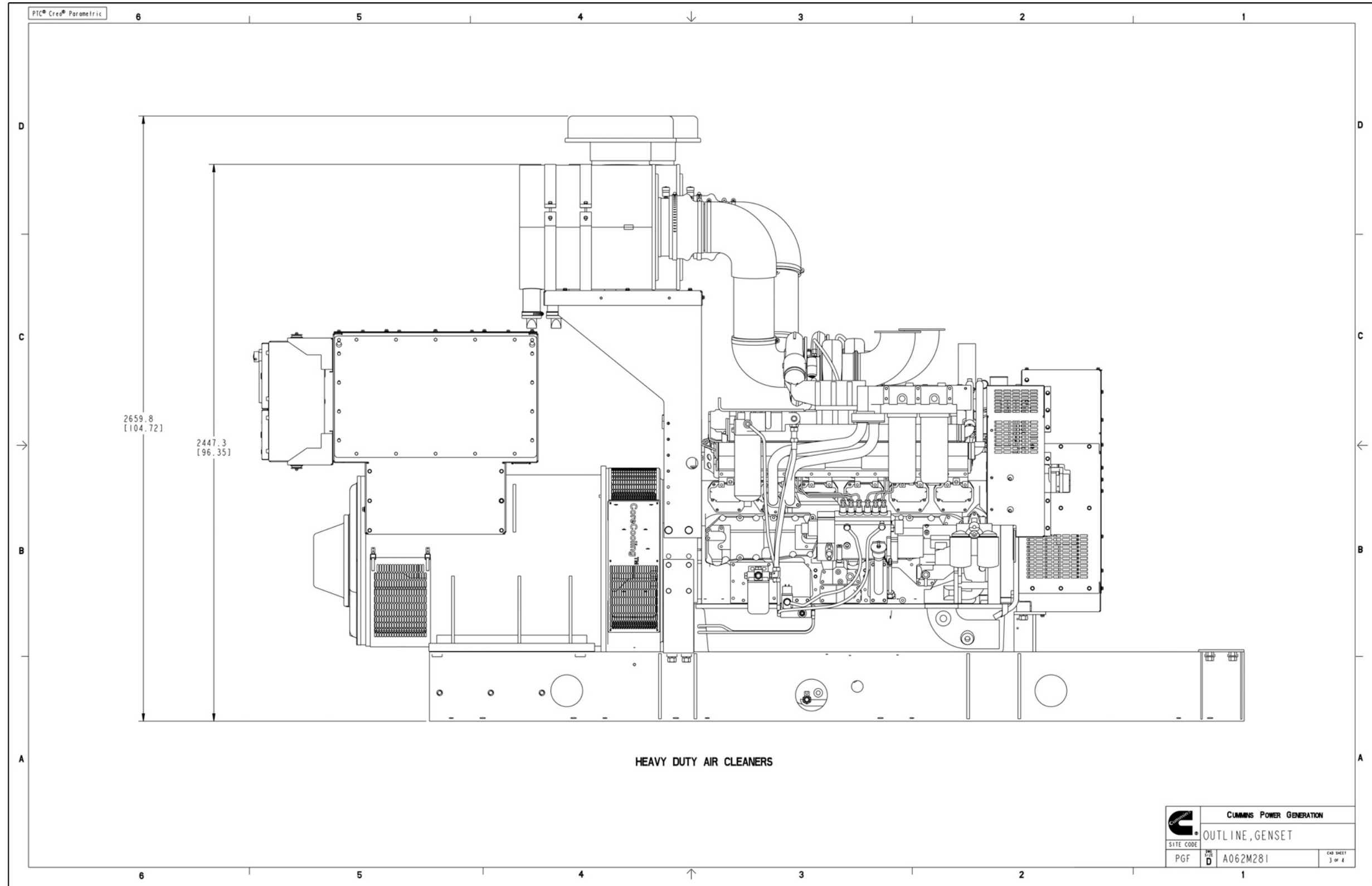

FIGURE 80. GENERATOR SET OUTLINE DRAWING (REMOTE RADIATOR) (SHEET 3)

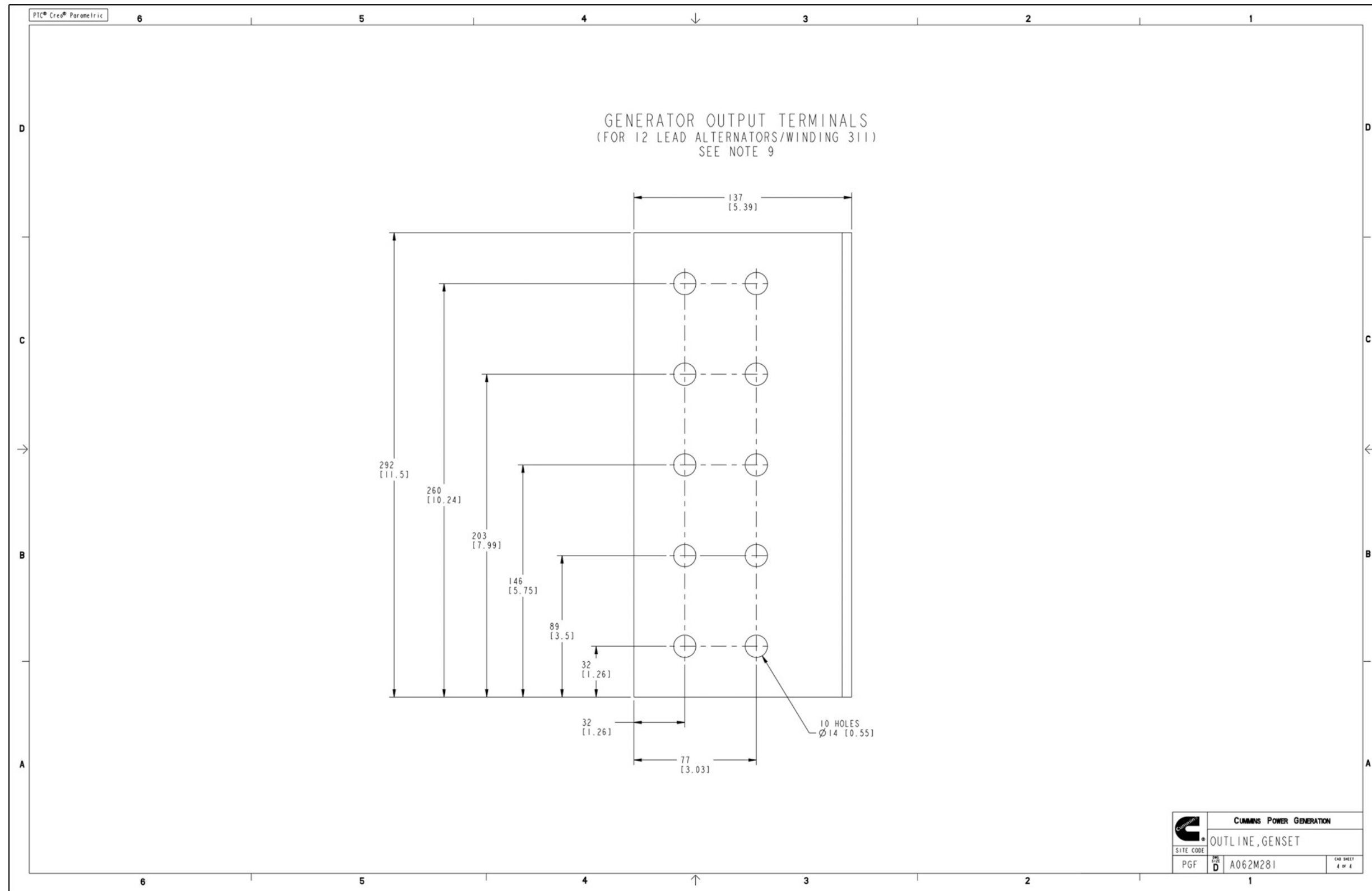

FIGURE 81. GENERATOR SET OUTLINE DRAWING (REMOTE RADIATOR) (SHEET 4)

This page is intentionally blank.

Appendix D. Seismic Requirements

Table of Contents

Figure 82. Seismic Installation Specifications 151
Figure 83. Seismic Installation Notes 152
Figure 84. Seismic Installation Requirements 153

The drawings included in this section are representative. For current complete information, refer to the drawing package that was shipped with the unit.

D.1 Seismic Installation Instructions (A045K403)

PIC® Creo® Parametric		6	5	4	3	2	1																								
							<table border="1"> <tr> <th>REV. NO.</th> <th>DATE</th> <th>BY</th> <th>CHKD.</th> <th>APPROV.</th> <th>DATE</th> </tr> <tr> <td>ECO-149219</td> <td>D</td> <td>1</td> <td>CJF</td> <td>KK</td> <td>14.JAN.15</td> </tr> <tr> <td></td> <td></td> <td>2</td> <td>CJF</td> <td>KK</td> <td>14.JAN.15</td> </tr> <tr> <td></td> <td></td> <td>3</td> <td>CJF</td> <td>KK</td> <td>14.JAN.15</td> </tr> </table>	REV. NO.	DATE	BY	CHKD.	APPROV.	DATE	ECO-149219	D	1	CJF	KK	14.JAN.15			2	CJF	KK	14.JAN.15			3	CJF	KK	14.JAN.15
REV. NO.	DATE	BY	CHKD.	APPROV.	DATE																										
ECO-149219	D	1	CJF	KK	14.JAN.15																										
		2	CJF	KK	14.JAN.15																										
		3	CJF	KK	14.JAN.15																										
GRADE/ROOF MOUNTED GENERATOR SETS																															
CUMMINS GENSET MODEL	CONFIGURATION	SEISMIC ISOLATOR	QTY	ATTACHMENT TO STEEL		ATTACHMENT TO CONCRETE																									
				ISOLATOR ATTACHMENT HARDWARE TO STEEL	ISOLATOR ATTACHMENT HARDWARE TO CONCRETE	ANCHOR EMBEDMENT	MINIMUM EDGE DISTANCE (FROM ANCHOR LOCATION)	CONCRETE COMPRESSIVE STRENGTH	SLAB THICKNESS																						
1 DOCA, DOCB, DOCC	SET-MOUNTED COOLING	A034C357	8	4 PER ISOLATOR (32 TOTAL) 3/4" DIA, ASTM A325 BOLTS	4 PER ISOLATOR (32 TOTAL) HILTI KWIK BOLT TZ - CS, Ø 3/4" X 4.75" (M20 X 120mm)	120mm MIN.	254mm MIN.	4,000 PSI MIN.	305mm MIN.																						
		A050E753																													
2 DOFAA, DOFAB, DOFAE, DOFAF, DOFAC, DOFAD, DOFAG, DOFAH	SET-MOUNTED & REMOTE COOLING	A034C357	10	4 PER ISOLATOR (40 TOTAL) 3/4" DIA, ASTM A325 BOLTS	4 PER ISOLATOR (40 TOTAL) HILTI KWIK BOLT TZ - CS, Ø 3/4" X 4.75" (M20 X 120mm)	120mm MIN.	356mm MIN.	4,000 PSI MIN.	305mm MIN.																						
		A050E753																													
3 DOPAA, DOPAB	SET-MOUNTED COOLING	A034C357	8	4 PER ISOLATOR (32 TOTAL) 3/4" DIA, ASTM A325 BOLTS	4 PER ISOLATOR (32 TOTAL) HILTI KWIK BOLT TZ - CS, Ø 3/4" X 4.75" (M20 X 120mm)	120mm MIN.	203mm MIN.	4,000 PSI MIN.	203mm MIN.																						
		A050E753																													
GRADE/ROOF MOUNTED LIFTING BASES																															
CUMMINS GENSET MODEL	FEATURE CODE	CONFIGURATION	CONCRETE ANCHORS	ANCHOR EMBEDMENT	MINIMUM EDGE DISTANCE (FROM ANCHOR LOCATION)	CONCRETE COMPRESSIVE STRENGTH	CONCRETE SLAB THICKNESS																								
DOPAA, DOPAB, DOCA, DOCB, DOCC, DOFAA, DOFAB, DOFAC, DOFAD	F200	LIFTING BASE	HILTI KWIK BOLT TZ - CS, QTY 12 Ø 3/4" X 4.75" (M20 X 254mm)	120mm MIN.	305mm MIN.	4,000 PSI MIN.	305mm MIN.																								
	F203																														
DOPAA, DOPAB, DOCA, DOCB, DOCC, DOFAA, DOFAB, DOFAC, DOFAD	F201	LIFTING BASE	HILTI KWIK BOLT TZ - CS, QTY 16 Ø 3/4" X 4.75" (M20 X 254mm)	120mm MIN.	254mm MIN.	4,000 PSI MIN.	254mm MIN.																								
	F204																														
DOPAA, DOPAB, DOCA, DOCB, DOCC, DOFAA, DOFAB, DOFAC, DOFAD	F202	LIFTING BASE	HILTI KWIK BOLT TZ - CS, QTY 18 Ø 3/4" X 4.75" (M20 X 254mm)	120mm MIN.	254mm MIN.	4,000 PSI MIN.	254mm MIN.																								
	F205																														
GRADE/ROOF MOUNTED FUEL TANKS																															
FEATURE CODE	CUMMINS FUEL TANK PART NUMBER	GALLONS	CONFIGURATION	SEISMIC LEVEL	CONCRETE ANCHORS	ANCHOR EMBEDMENT	EDGE DISTANCE (FROM CORNER ANCHOR LOCATION)	CONCRETE COMPRESSIVE STRENGTH	CONCRETE SLAB THICKNESS																						
C253	A045S870	2400	TANK	1.40 < SDS <= 1.94 Z/H = 0.0	(QTY 18) 0.79" DIA. UNDERCUT ANCHORS HILTI HDA-P, M20 X 250-50	250mm MIN.	305mm MIN.	4,000 PSI MIN.	356mm MIN.																						
				SDS < 1.40 Z/H = 0.0	(QTY 18) 3/4" DIA. EXPANSION ANCHORS HILTI KWIK BOLT TZ-CS	120mm MIN.	305mm MIN.	4,000 PSI MIN.	305mm MIN.																						
C252	A040X449	2000	TANK	1.20 < SDS <= 1.94 Z/H = 0.0	(QTY 16) 0.79" DIA. UNDERCUT ANCHORS HILTI HDA-P, M20 X 250-50	250mm MIN.	356mm MIN.	4,000 PSI MIN.	356mm MIN.																						
				SDS < 1.20 Z/H = 0.0	(QTY 16) 3/4" DIA. EXPANSION ANCHORS HILTI KWIK BOLT TZ-CS	120mm MIN.	305mm MIN.	4,000 PSI MIN.	305mm MIN.																						
C250 C251	A045P211 A045P210	1000 1500	TANK	0.95 < SDS <= 1.94 Z/H = 0.0	(QTY 12) 0.79" DIA. UNDERCUT ANCHORS HILTI HDA-P, M20 X 250-50	250mm MIN.	406.4mm MIN.	4,000 PSI MIN.	356mm MIN.																						
				SDS < 0.95 Z/H = 0.0	(QTY 12) 3/4" DIA. EXPANSION ANCHORS HILTI KWIK BOLT TZ-CS	120mm MIN.	305mm MIN.	4,000 PSI MIN.	305mm MIN.																						
C205 C249	A045P209 A045P208	660 200	TANK	1.10 < SDS <= 1.94 Z/H = 0.0	(QTY 12) 0.79" DIA. UNDERCUT ANCHORS HILTI HDA-P, M20 X 250-50	250mm MIN.	356mm MIN.	4,000 PSI MIN.	356mm MIN.																						
				SDS < 1.10 Z/H = 0.0	(QTY 12) 3/4" DIA. EXPANSION ANCHORS HILTI KWIK BOLT TZ-CS	120mm MIN.	254mm MIN.	4,000 PSI MIN.	305mm MIN.																						

-THIS IS A CONTROLLED ITEM-
FOR CPG PROCEDURE PRE-1002
TO MAINTAIN COMPLIANCE WITH REQUIREMENTS OF THE CODES, STANDARDS, OR REGULATIONS LISTED BELOW:
 ASME AWS API ASME ASME
 ASME ASME ASME
 CHANGE, DEVIATION, OR SUBSTITUTION OF MATERIAL, PROCESS, OR PERFORMANCE FOR THIS ITEM MUST BE APPROVED BY THE FOLLOWING CONTROLLED ITEM APPROVER:
 RESPONSIBLE CIA ROLE STATIONARY GENSET CIA
 RESPONSIBLE CIA ROLE
 RESPONSIBLE CIA ROLE

UNLESS OTHERWISE SPECIFIED, ALL DIMENSIONS ARE IN MILLIMETERS		REV. NO. A030B114	DESIGNER M. JURISCH	CUMMINS POWER GENERATION	
DO NOT SCALE PRINT		APPV. V. KODIMALA	CHKD. V. GUPTA	INSTALLATION, GENSET	
ANG TOL: ± 1.0° SCALE: 1/1		DATE 20FEB13	DATE 20FEB13	SEISMIC REQUIREMENTS	
- CONFIDENTIAL - PROPERTY OF CUMMINS POWER GENERATION GROUP		FOR INTERPRETATION FIRST USE IN OF DIMENSIONS AND TOLERANCES, SEE ASME Y14.3M-1994	PGF	SITE CODE A045K403	SHEET 1 OF 3

FIGURE 82. SEISMIC INSTALLATION SPECIFICATIONS



FIGURE 83. SEISMIC INSTALLATION NOTES

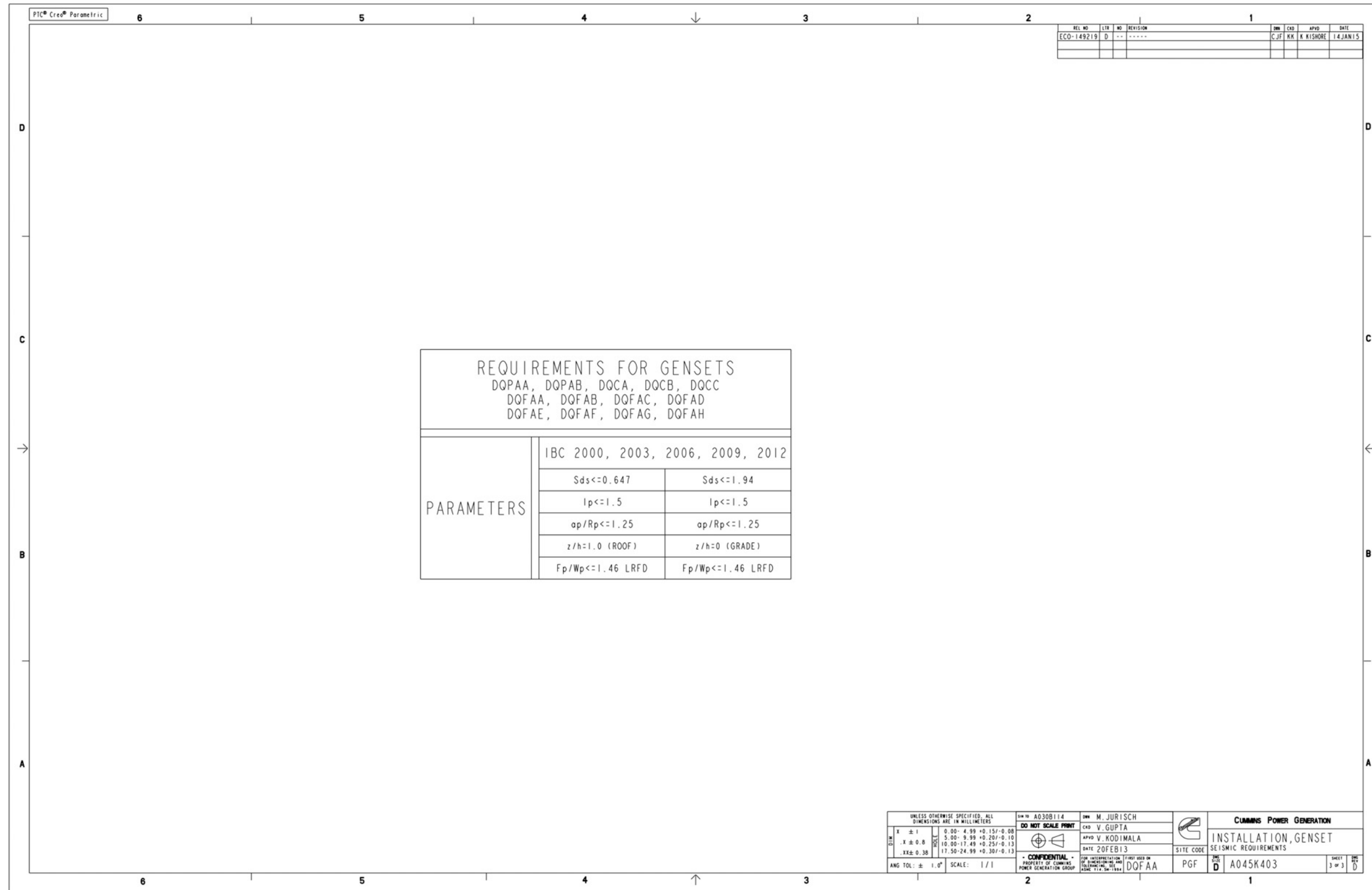

FIGURE 84. SEISMIC INSTALLATION REQUIREMENTS

This page is intentionally blank.

Appendix E. Wiring Diagrams

Table of Contents

- Figure 85. Sheet 1 of 8 157
- Figure 86. Sheet 2 of 8 158
- Figure 87. Sheet 3 of 8 159
- Figure 88. Sheet 4 of 8 160
- Figure 89. Sheet 5 of 8 161
- Figure 90. Sheet 6 of 8 162
- Figure 91. Sheet 7 of 8 163
- Figure 92. Sheet 8 of 8 164
- Figure 93. Heater Outline Drawing and Schematic 165
- Figure 94. Wiring for Options (Sheet 1 of 2) 166
- Figure 95. Wiring for Options (Sheet 2 of 2) 167
- Figure 96. Wiring Diagram (Sheet 1) 168
- Figure 97. Wiring Diagram (Sheet 2) 169
- Figure 98. Wiring Diagram (Sheet 3) 170
- Figure 99. Wiring Diagram (Sheet 4) 171
- Figure 100. Wiring Diagram (Sheet 5) 172
- Figure 101. Wiring Diagram (Sheet 6) 173
- Figure 102. Wiring Diagram (Sheet 7) 174
- Figure 103. Wiring Diagram (Sheet 8) 175
- Figure 104. Wiring Diagram (Sheet 9) 176
- Figure 105. Wiring Diagram (Sheet 10) 177
- Figure 106. Wiring Diagram (Sheet 11) 178
- Figure 107. Wiring Diagram (Sheet 12) 179

The drawings included in this section are representative. For current complete information, refer to the drawing package that was shipped with the unit.

E.1 PCC3300 Wiring Diagram (A053C830)

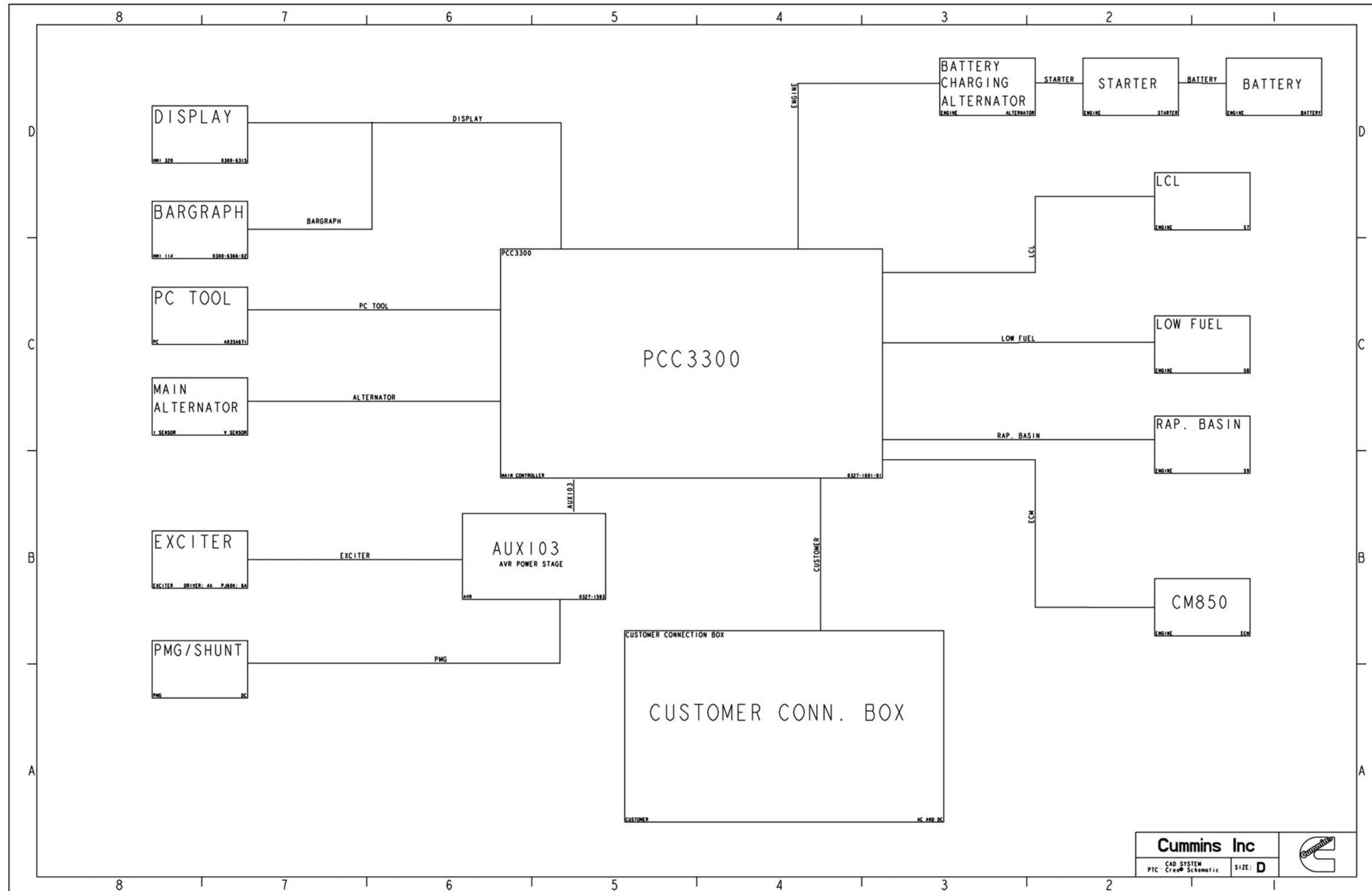

Part Number: **A053C830** Part Revision: **E**
 Part Name: **DIAGRAM,WIRING SCHEMATIC**

FIGURE 85. SHEET 1 OF 8

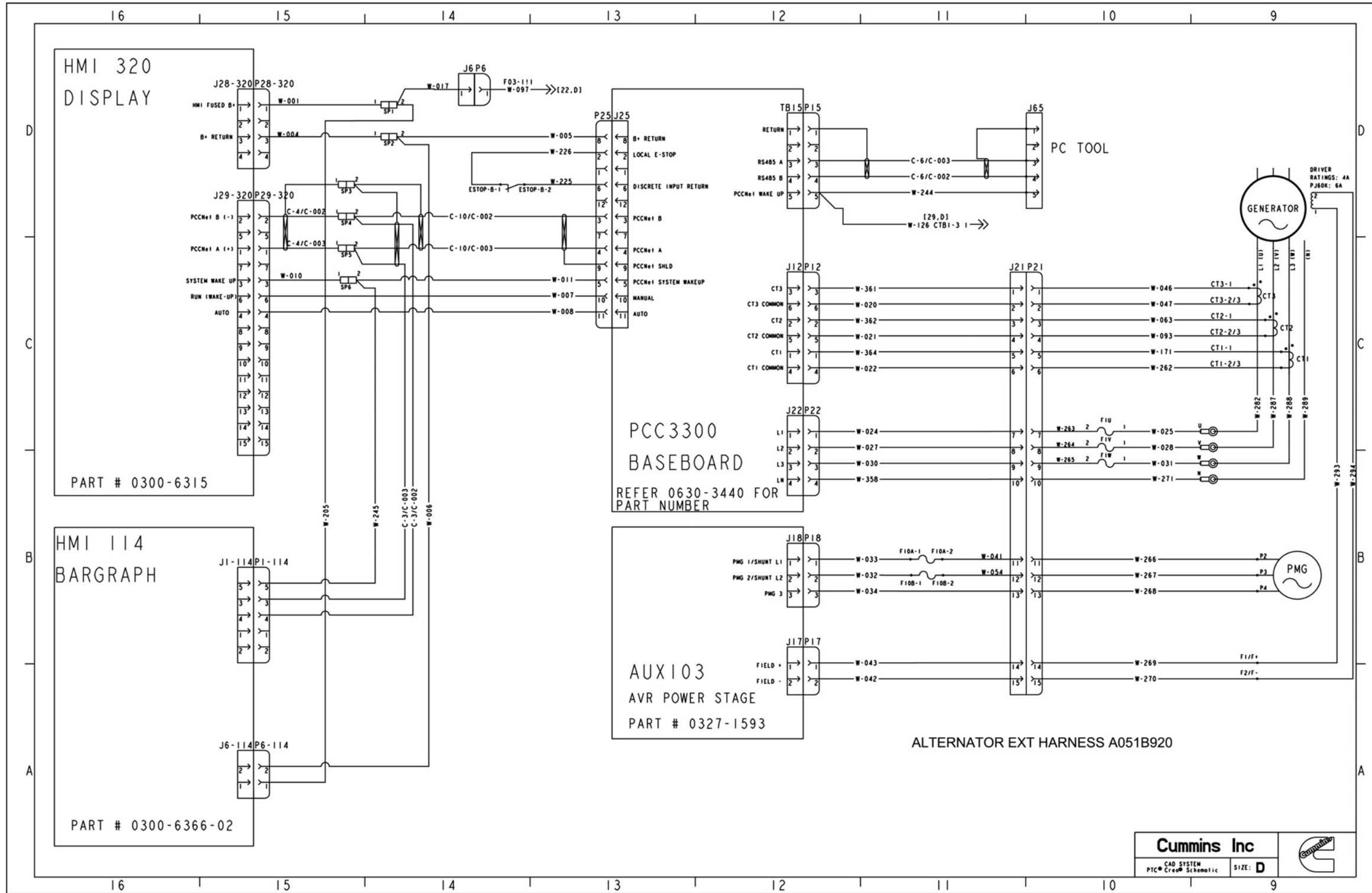

Part Number: **A053C830** Part Revision: **E**
 Part Name: **DIAGRAM, WIRING SCHEMATIC**

FIGURE 86. SHEET 2 OF 8

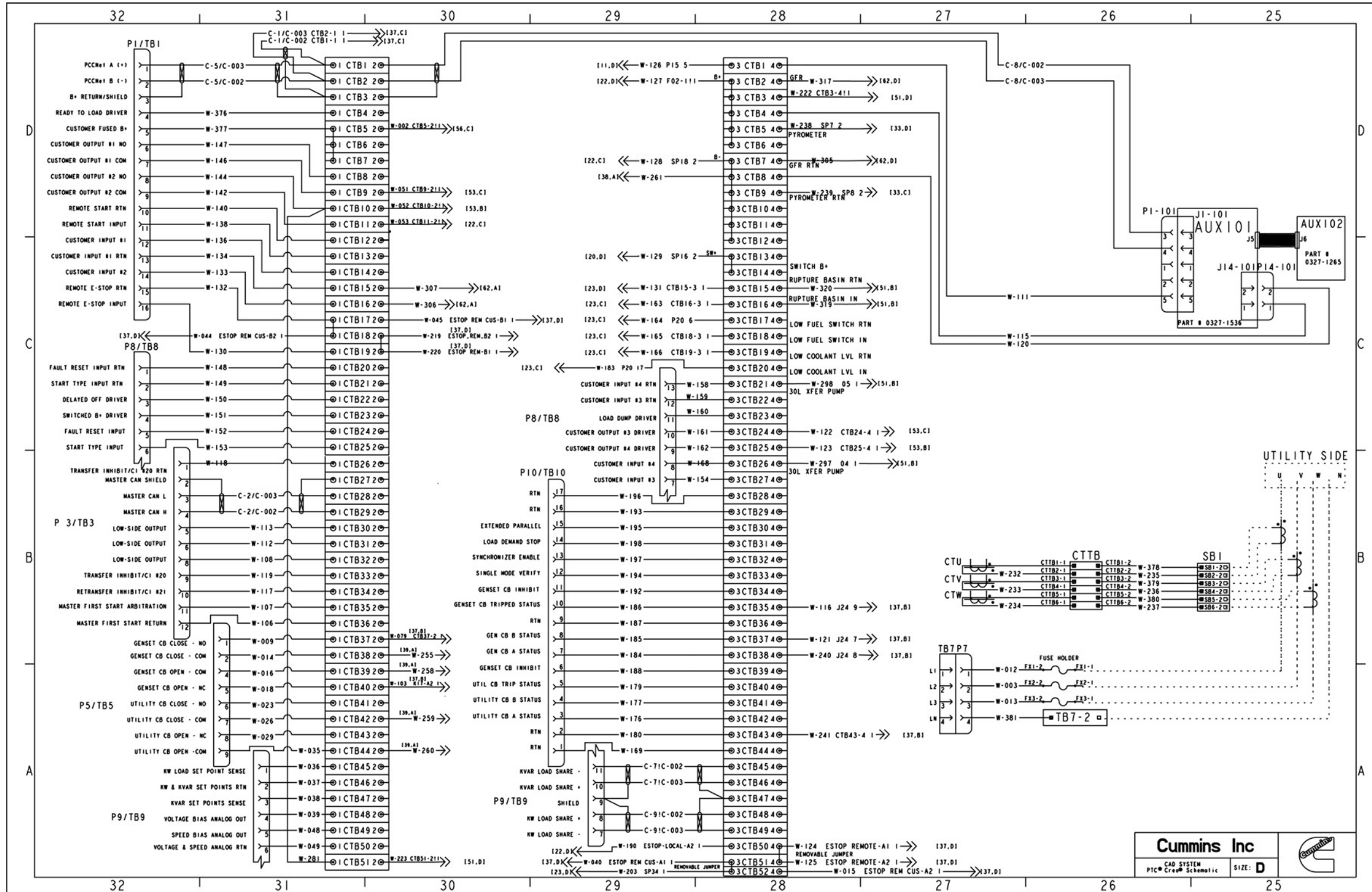

Part Number: A053C830 Part Revision: E
Part Name: DIAGRAM,WIRING SCHEMATIC

FIGURE 88. SHEET 4 OF 8

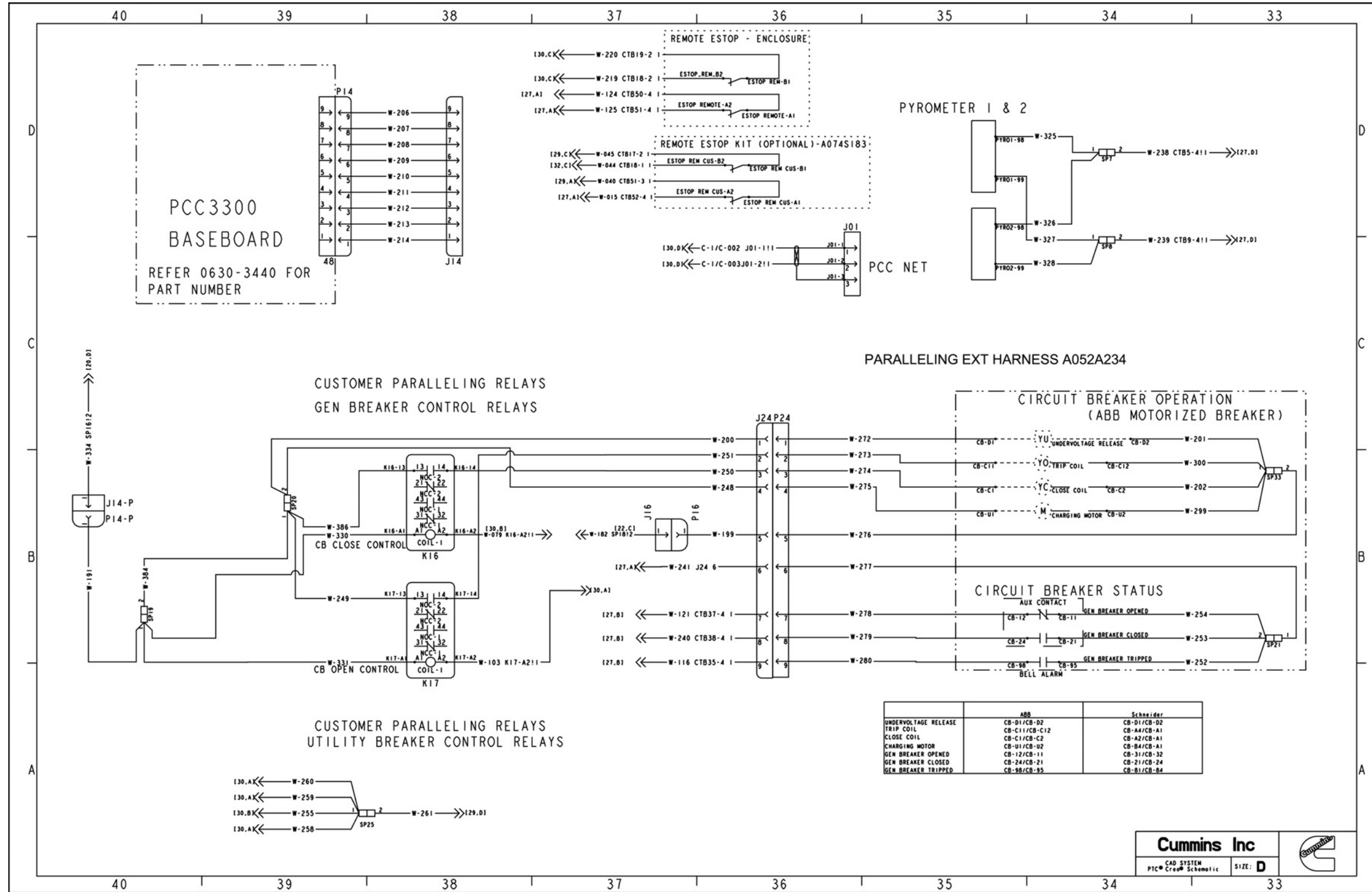

Part Number: **A053C830** Part Revision: **E**
 Part Name: **DIAGRAM,WIRING SCHEMATIC**

FIGURE 89. SHEET 5 OF 8

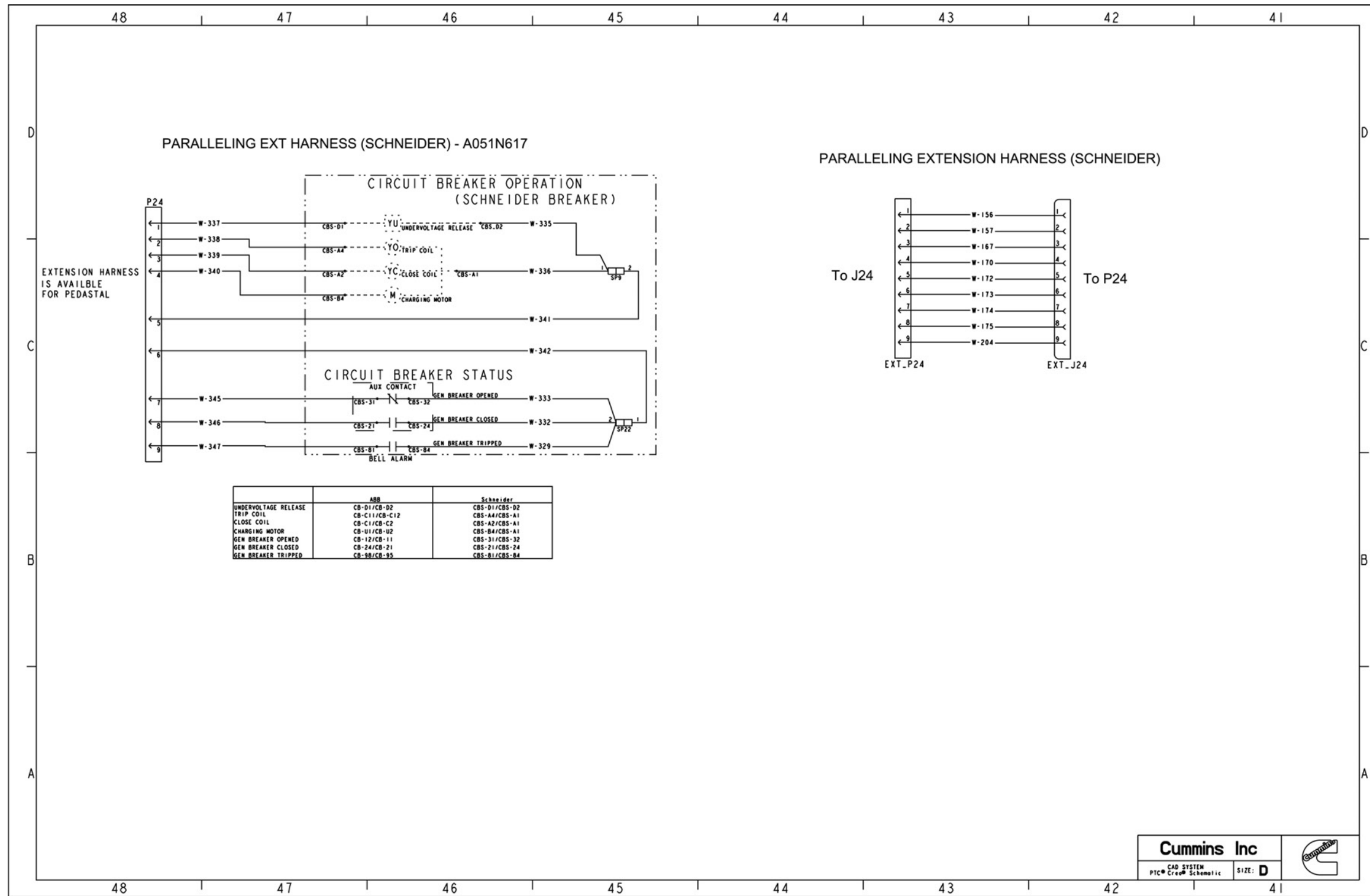

Part Number: **A053C830** Part Revision: **E**
 Part Name: **DIAGRAM, WIRING SCHEMATIC**

FIGURE 90. SHEET 6 OF 8

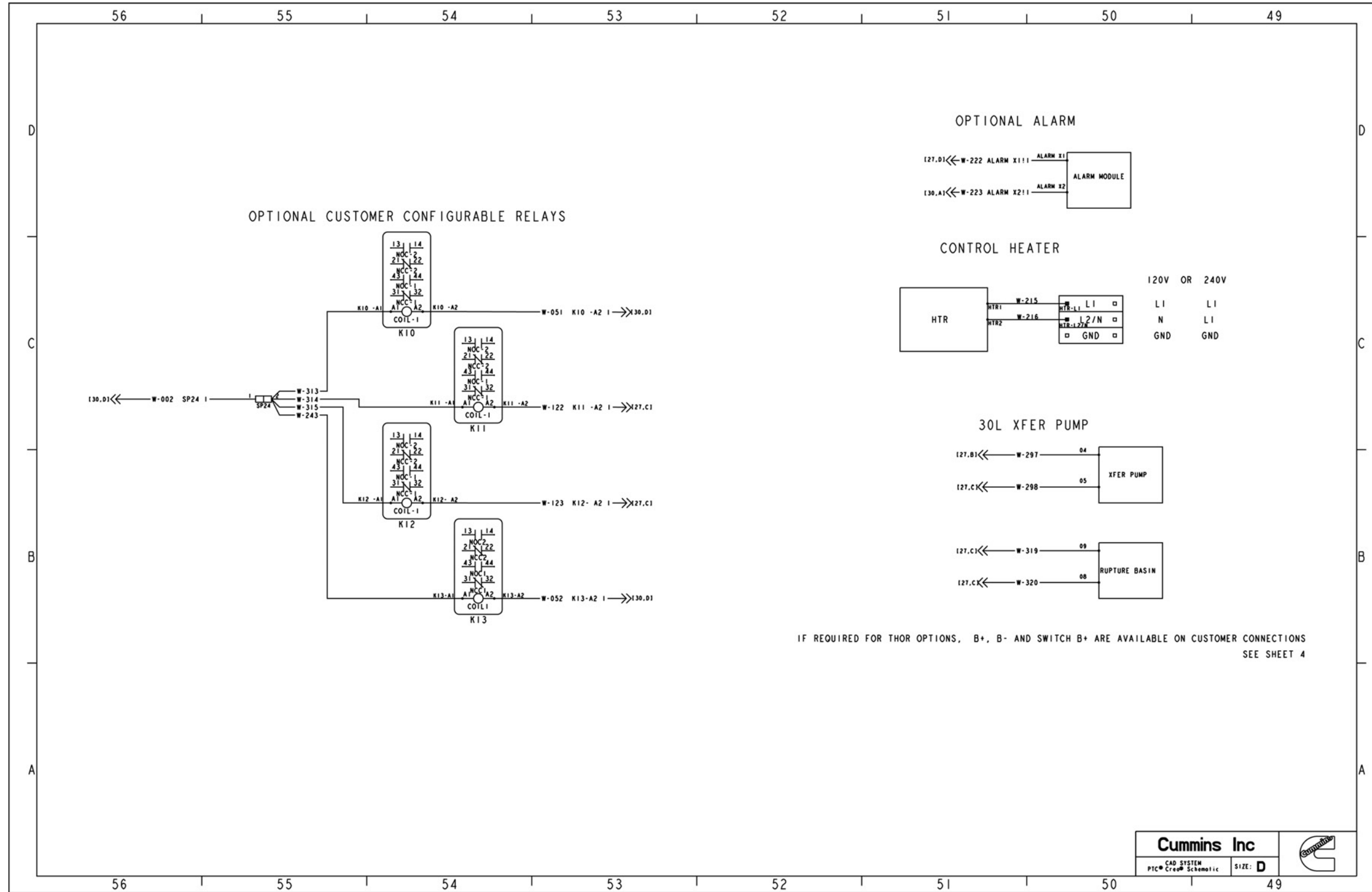

Part Number: **A053C830** Part Revision: **E**
 Part Name: **DIAGRAM,WIRING SCHEMATIC**

FIGURE 91. SHEET 7 OF 8

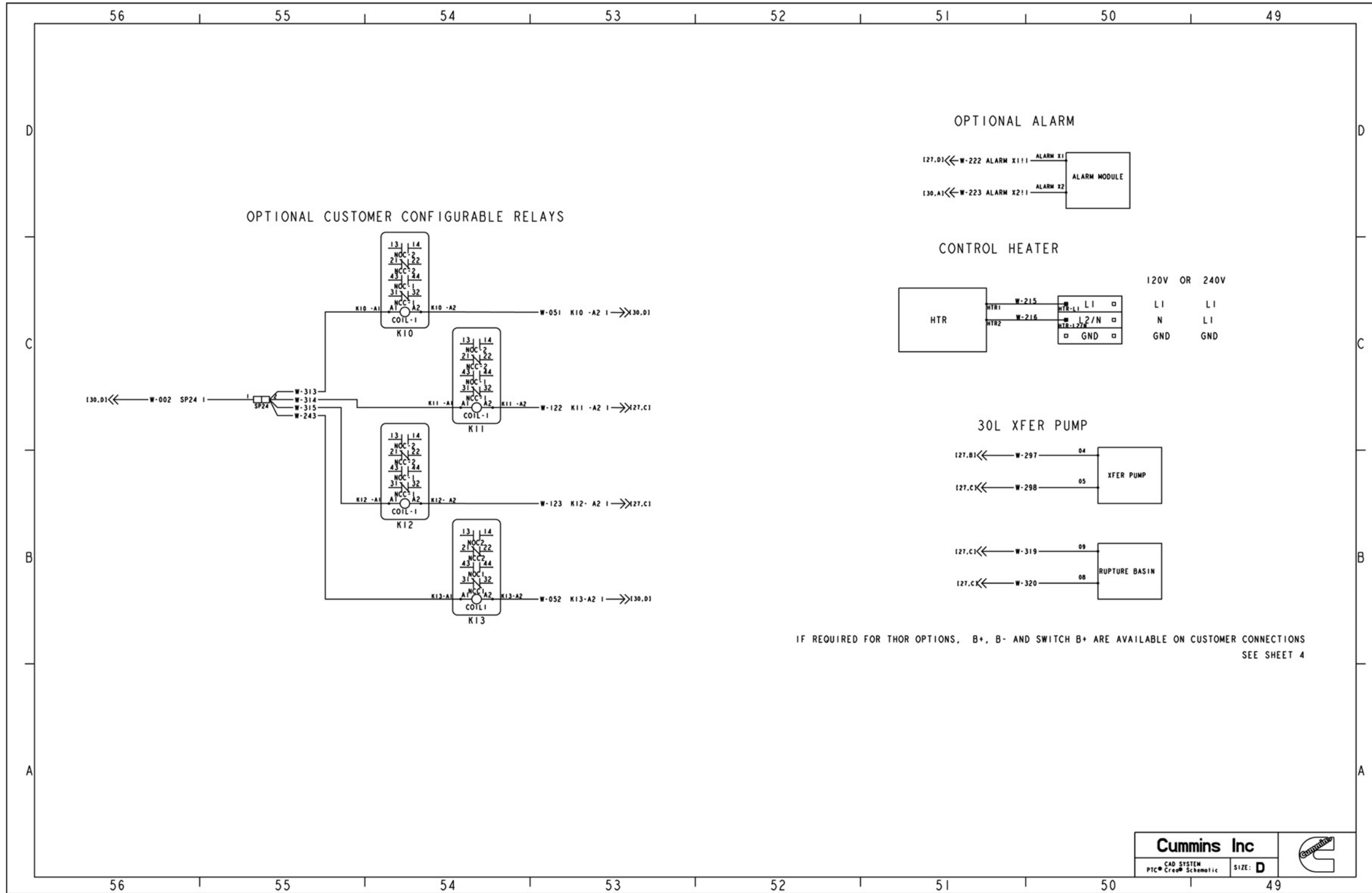

Part Number: **A053C830** Part Revision: **E**
 Part Name: **DIAGRAM, WIRING SCHEMATIC**

FIGURE 92. SHEET 8 OF 8

E.2 Outline Drawing and Schematic - Heater

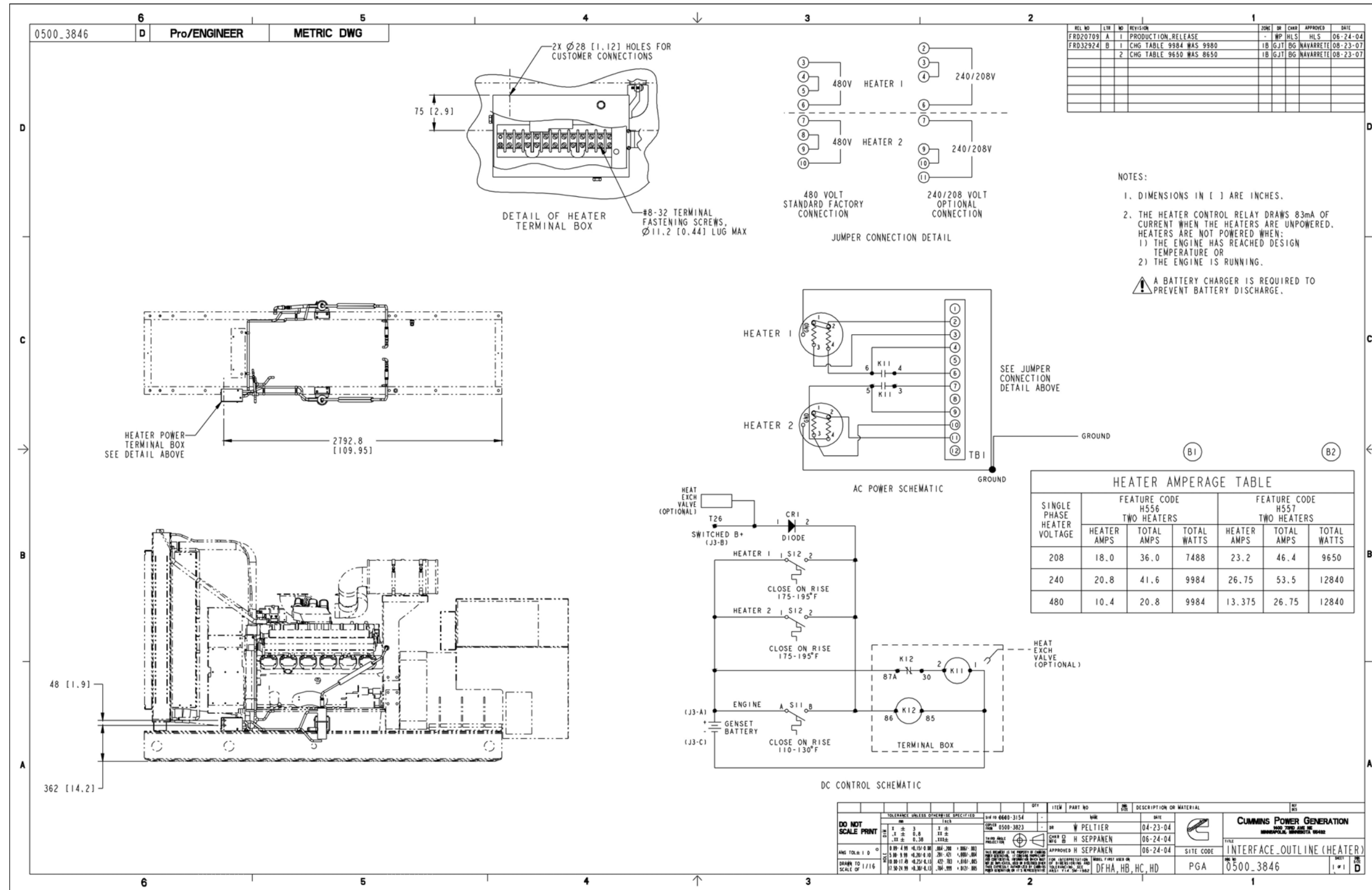

FIGURE 93. HEATER OUTLINE DRAWING AND SCHEMATIC

E.3 Wiring of Optional Equipment

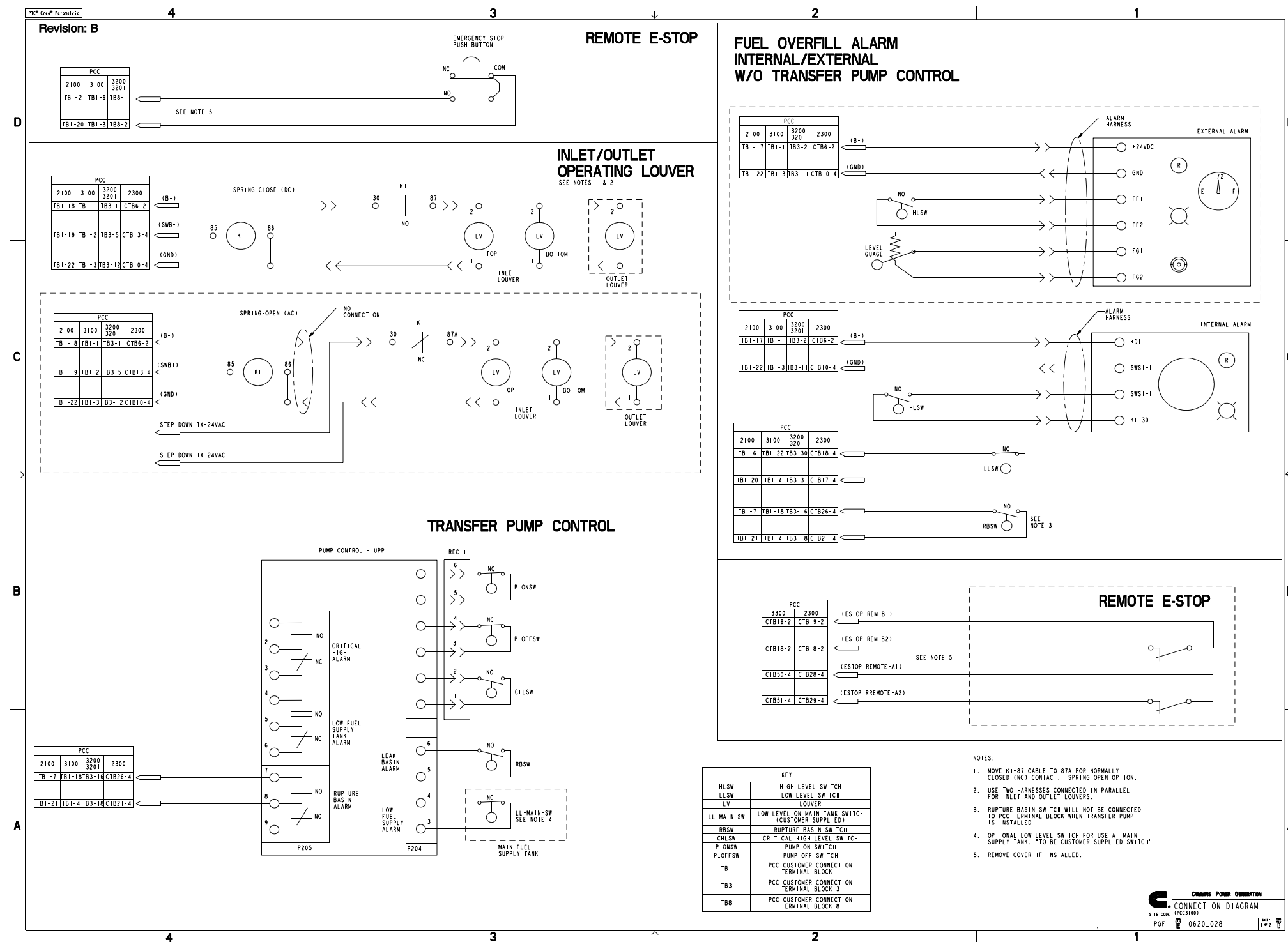

FIGURE 94. WIRING FOR OPTIONS (SHEET 1 OF 2)

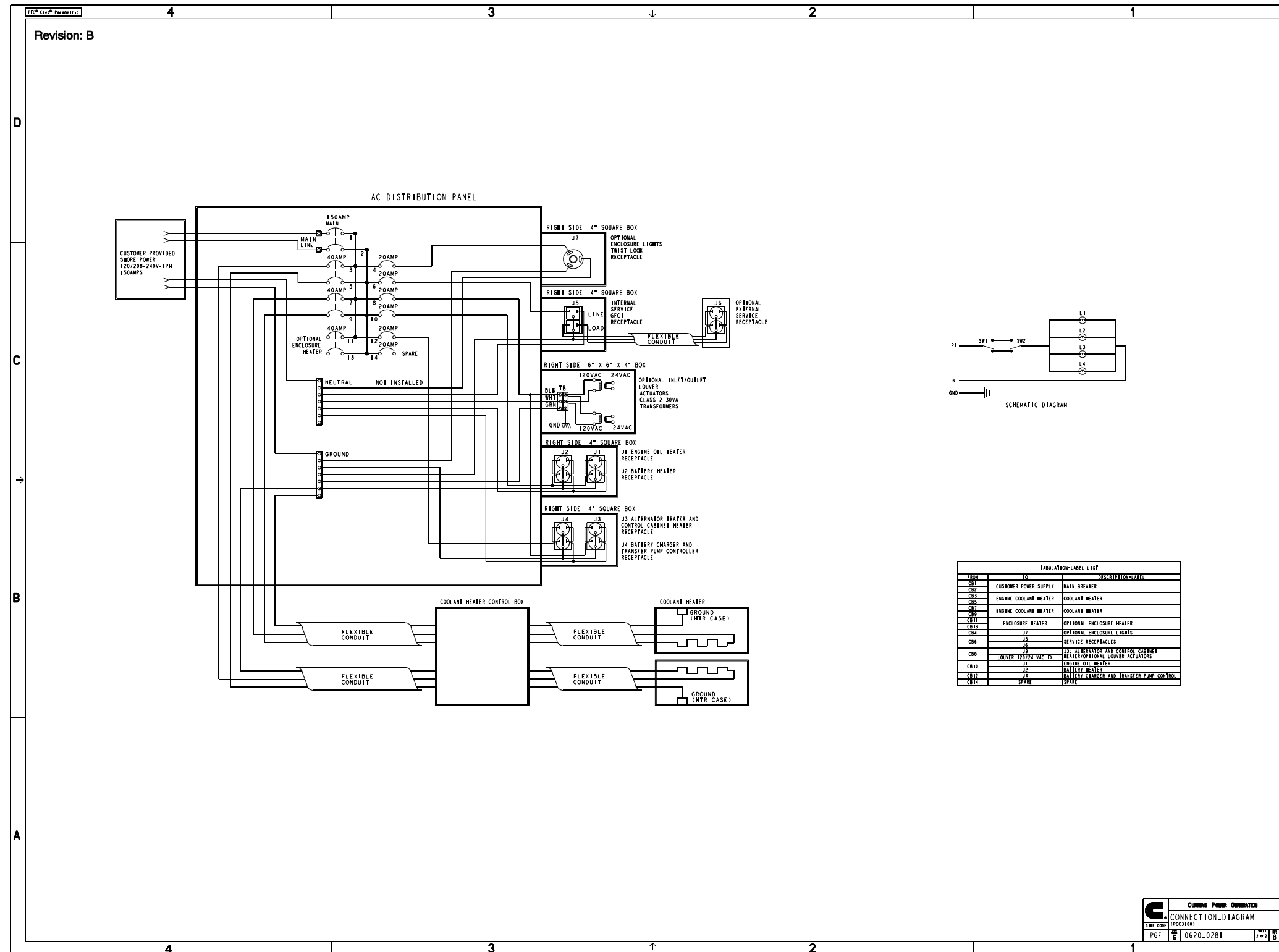

FIGURE 95. WIRING FOR OPTIONS (SHEET 2 OF 2)

E.4 Wiring Diagram with PowerCommand 3.3 or PowerCommand 3.3MLD Control

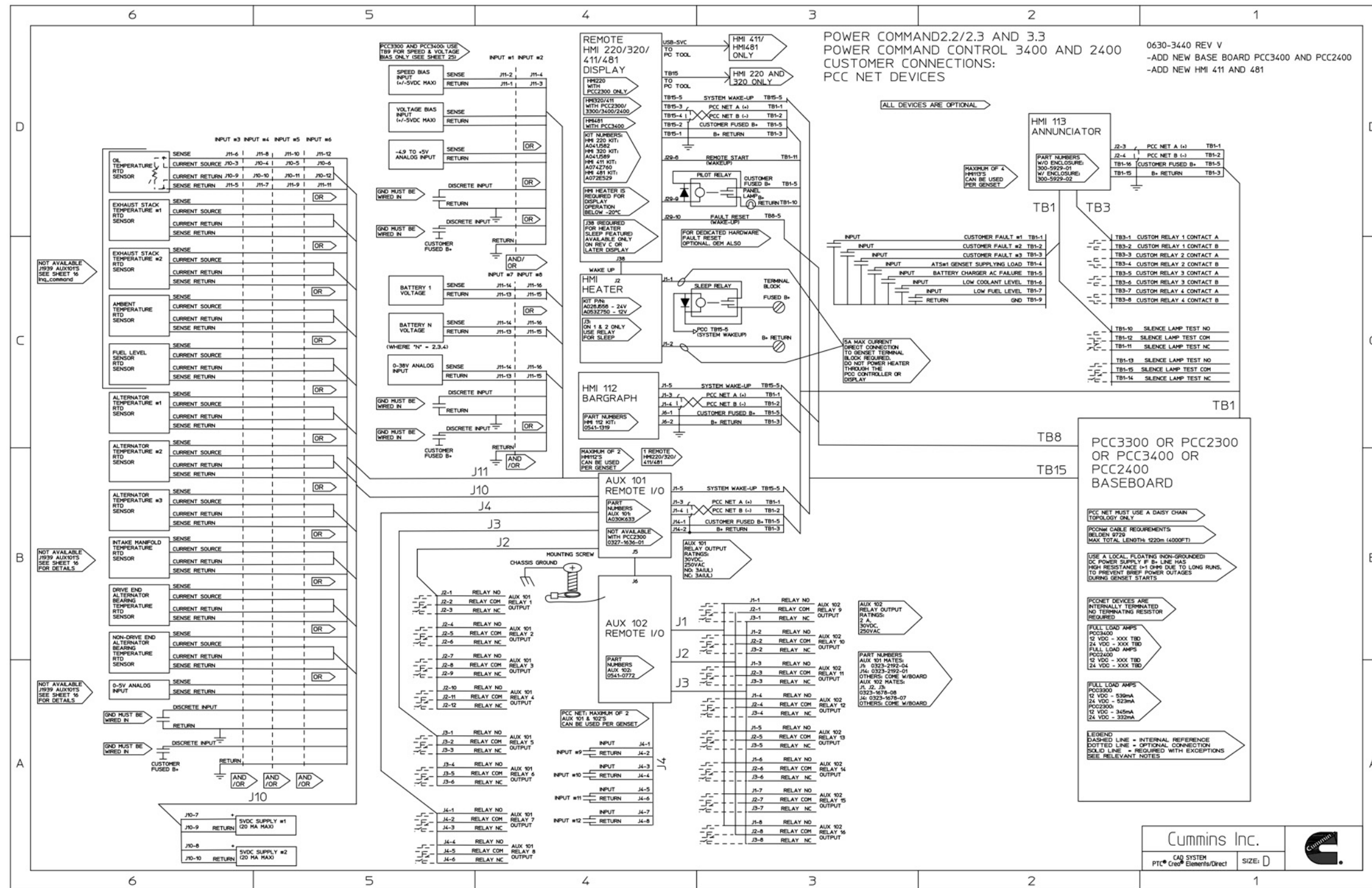
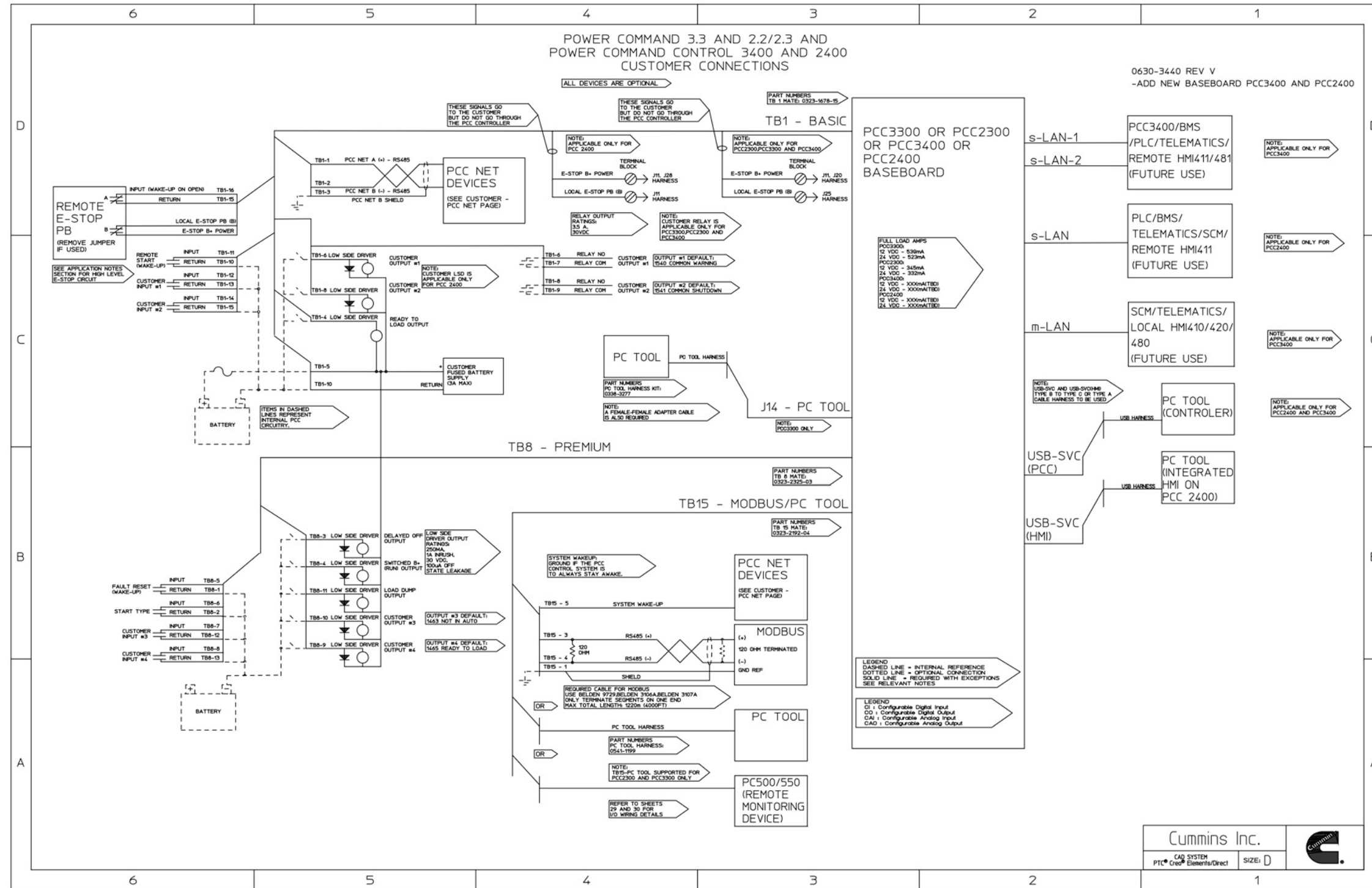
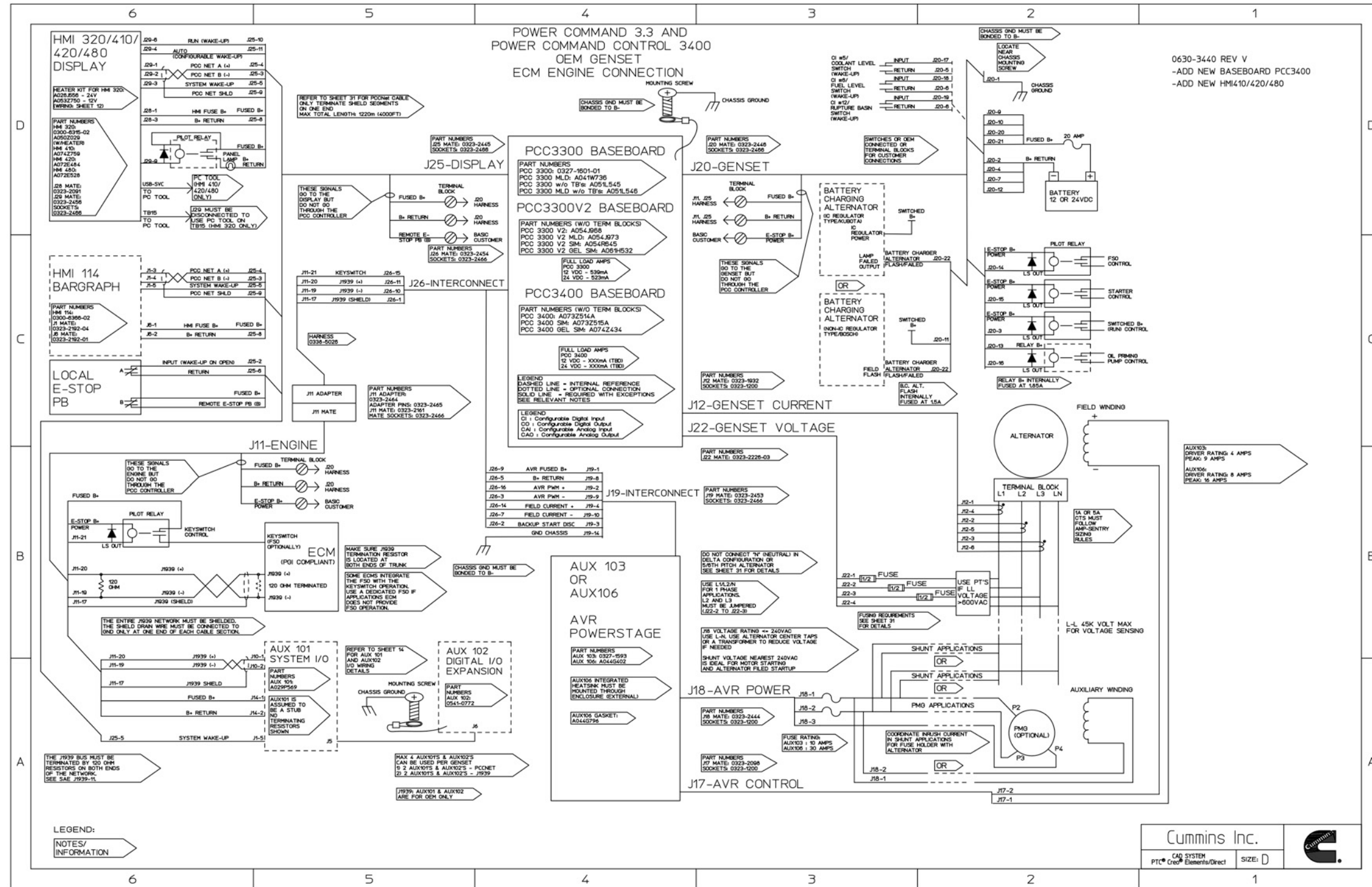

FIGURE 96. WIRING DIAGRAM (SHEET 1)



Part Number: 0630-3440 Part Revision: V
Part Name: DIAGRAM,CONTROL SCHEMATIC

FIGURE 97. WIRING DIAGRAM (SHEET 2)



Part Number: **0630-3440** Part Revision: **V**
 Part Name: **DIAGRAM,CONTROL SCHEMATIC**

FIGURE 98. WIRING DIAGRAM (SHEET 3)

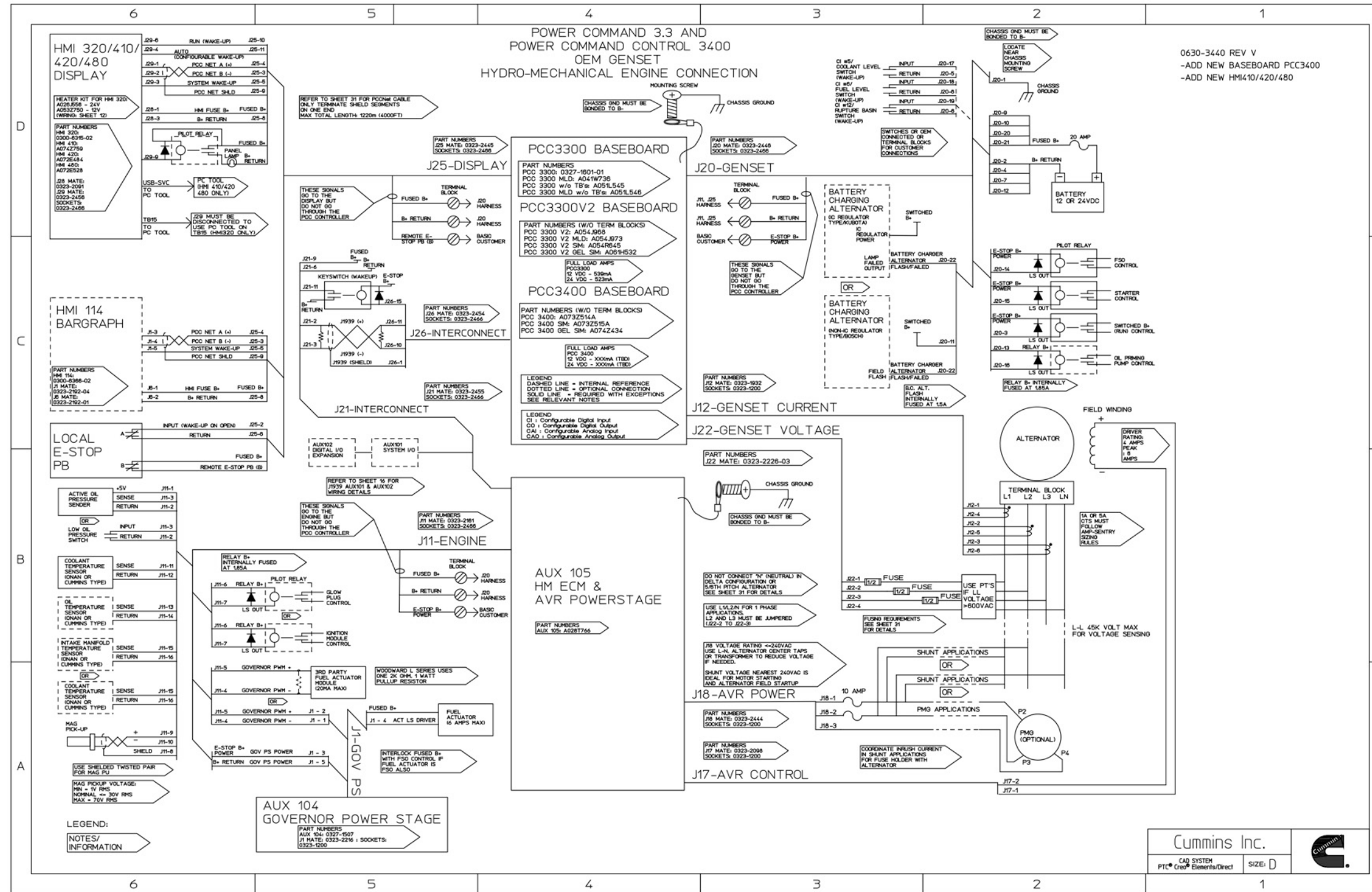

Part Number: 0630-3440 Part Revision: V
 Part Name: DIAGRAM,CONTROL SCHEMATIC

FIGURE 99. WIRING DIAGRAM (SHEET 4)

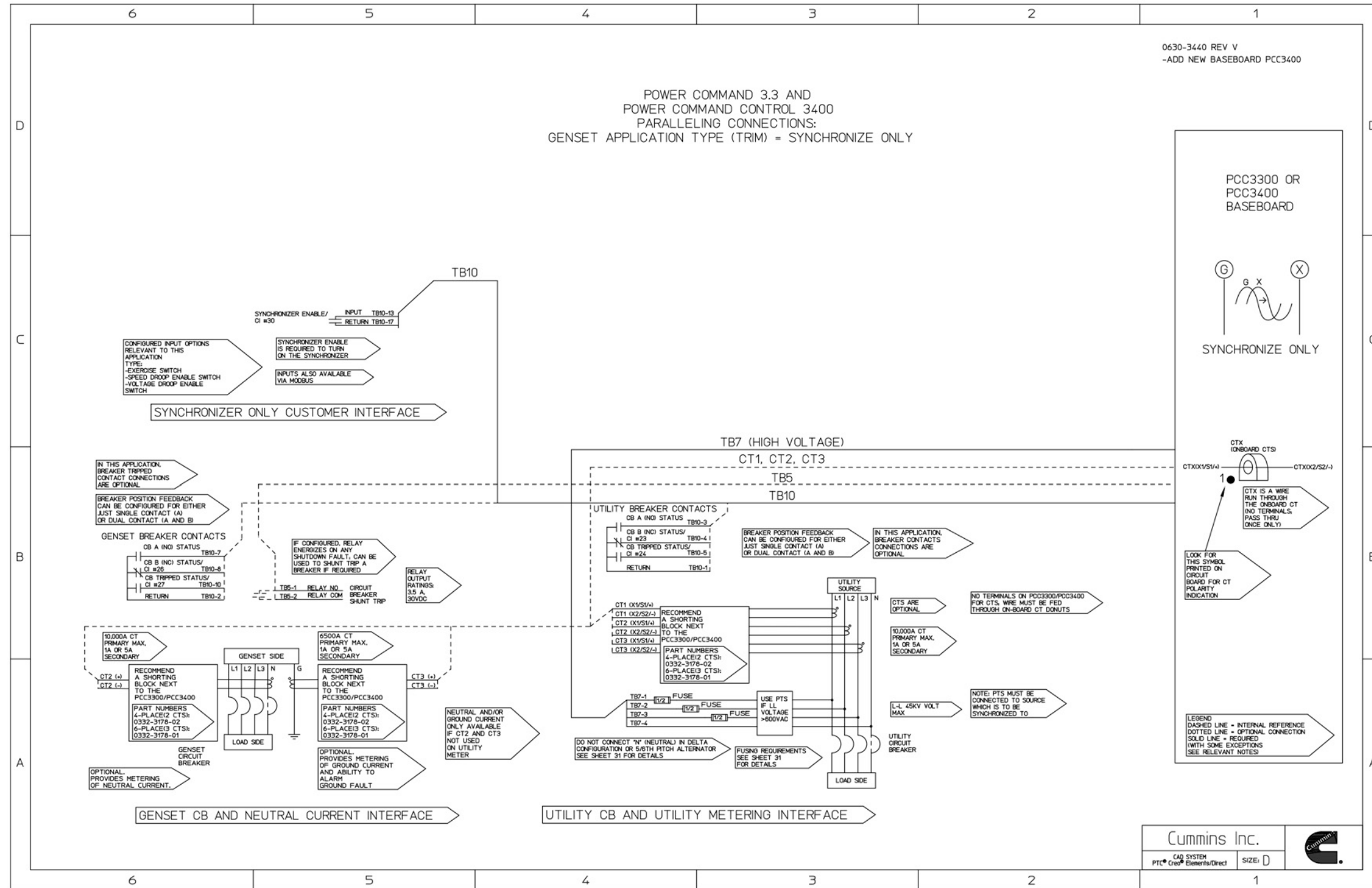

Part Number: 0630-3440 Part Revision: V
Part Name: DIAGRAM,CONTROL SCHEMATIC

FIGURE 100. WIRING DIAGRAM (SHEET 5)

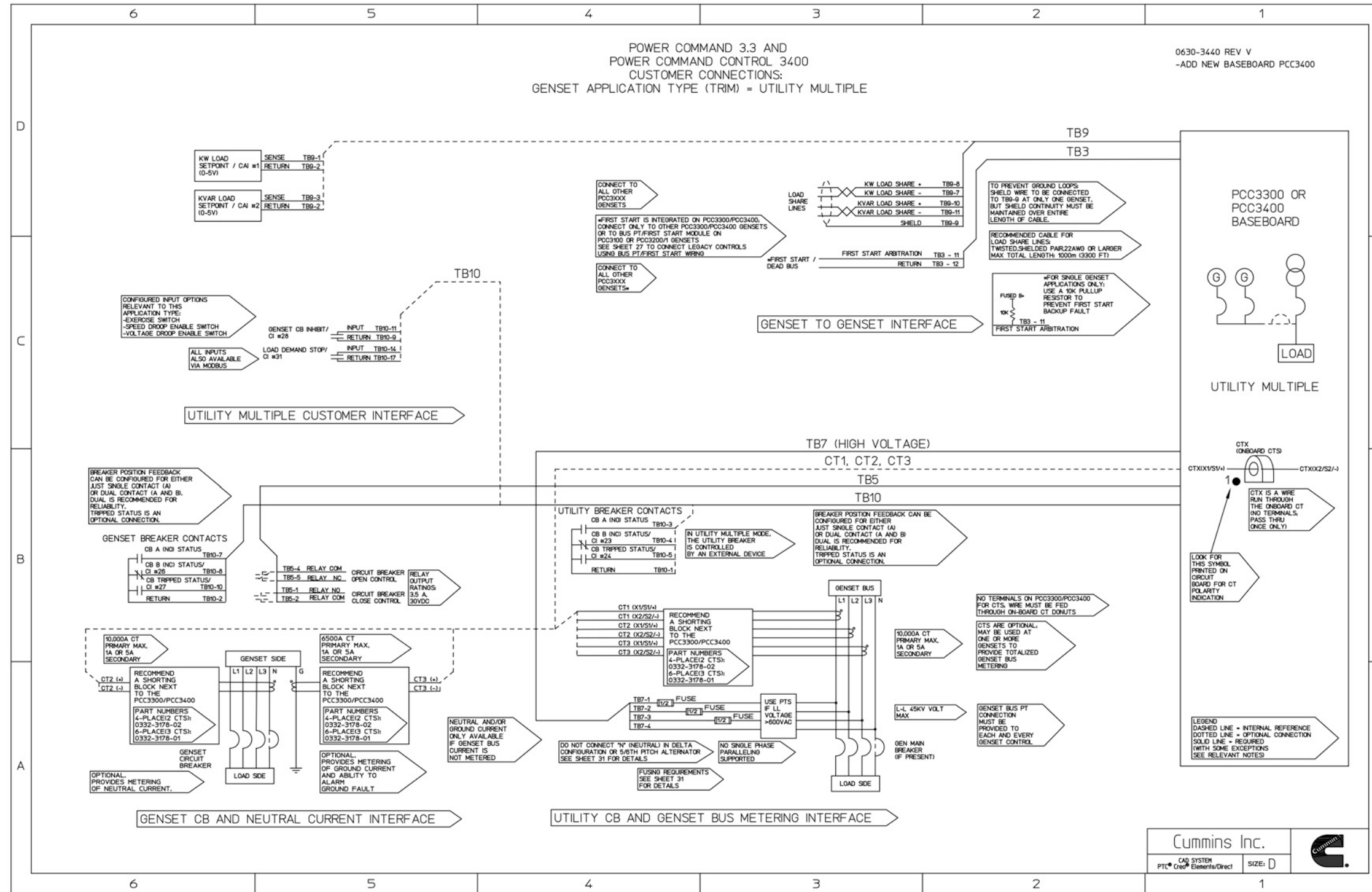

Part Number: 0630-3440 Part Revision: V
Part Name: DIAGRAM,CONTROL SCHEMATIC

FIGURE 103. WIRING DIAGRAM (SHEET 8)

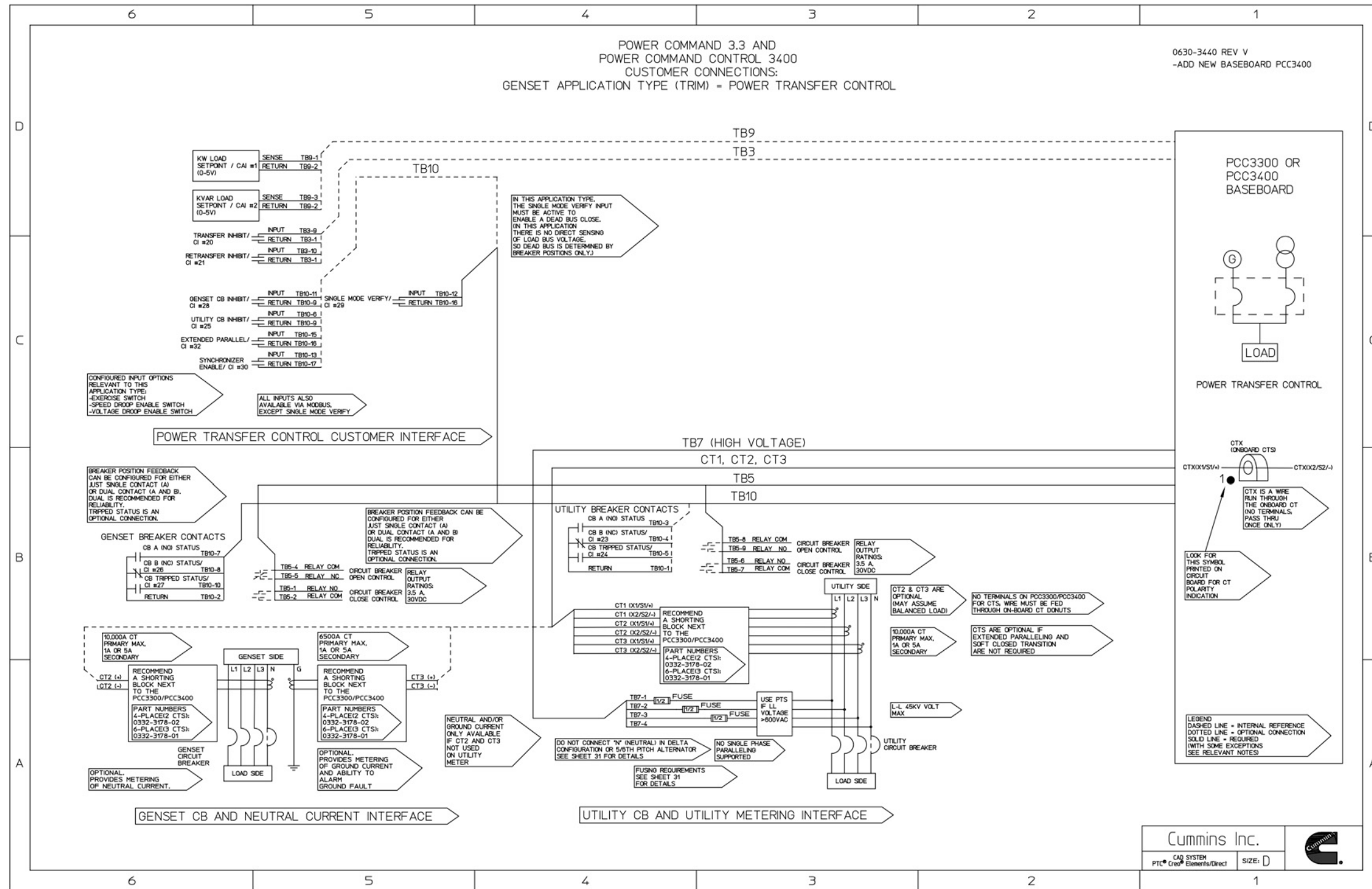

Part Number: 0630-3440 Part Revision: V
Part Name: DIAGRAM,CONTROL SCHEMATIC

FIGURE 104. WIRING DIAGRAM (SHEET 9)

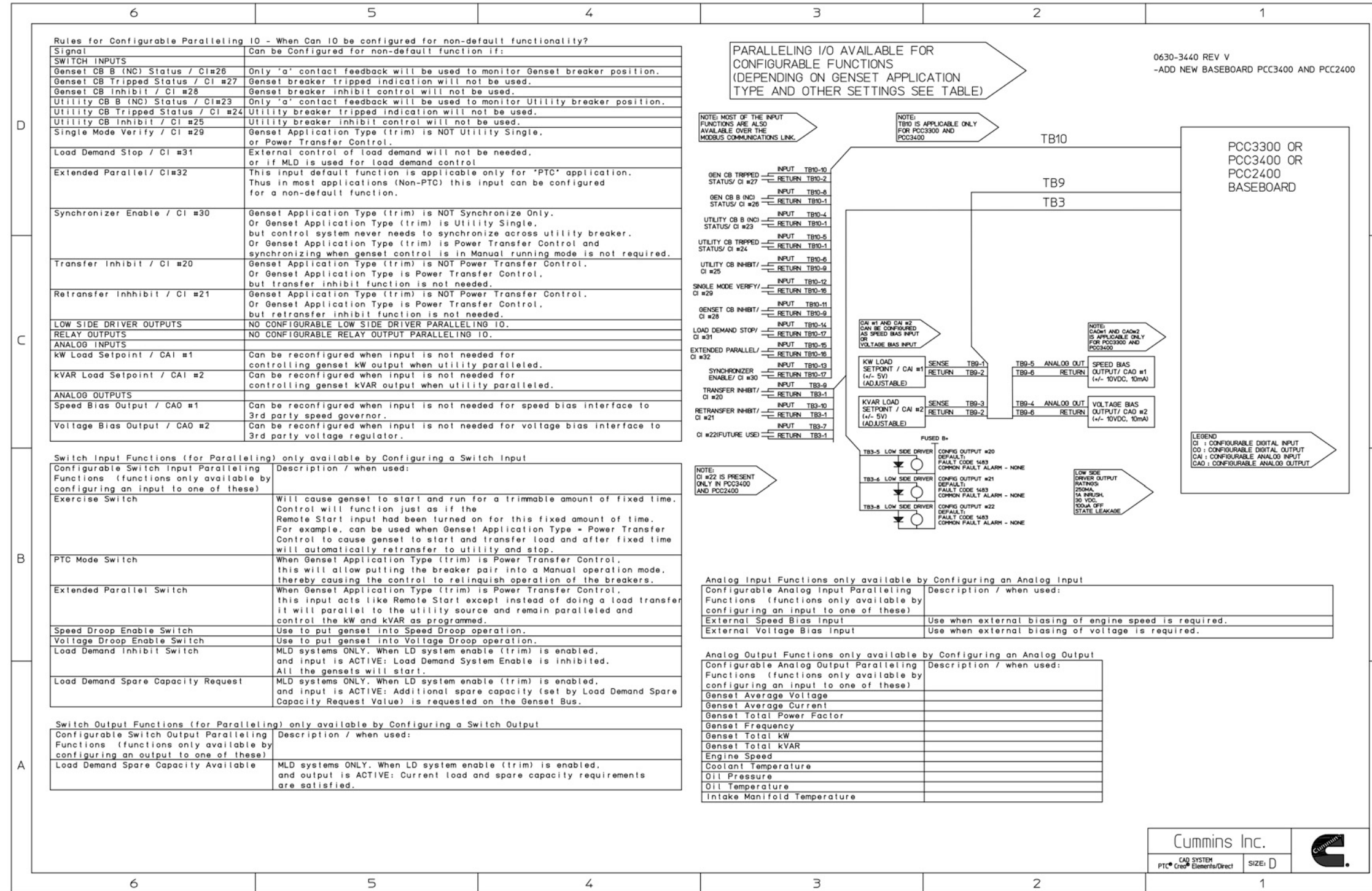

Part Number: 0630-3440 Part Revision: V
Part Name: DIAGRAM,CONTROL SCHEMATIC

FIGURE 105. WIRING DIAGRAM (SHEET 10)

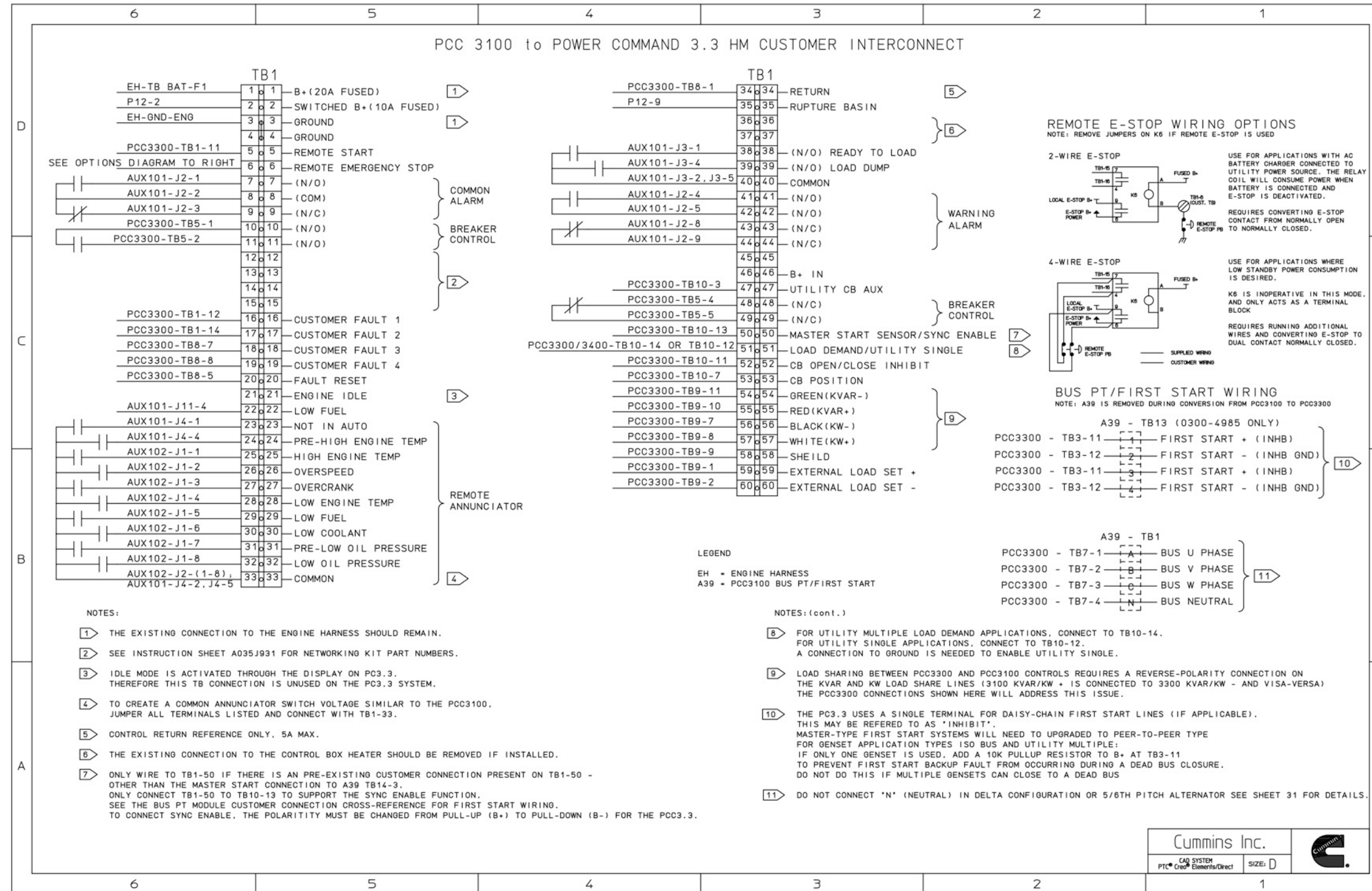

Part Number: **0630-3440** Part Revision: **V**
 Part Name: **DIAGRAM,CONTROL SCHEMATIC**

FIGURE 107. WIRING DIAGRAM (SHEET 12)

This page is intentionally blank.

power.cummins.com

Copyright © 2025 Cummins Inc. All rights reserved.

Cummins, the "C" logo, PowerCommand, AmpSentry, and InPower are trademarks of Cummins Inc.

Other company, product, or service names may be trademarks or service marks of others.

Specifications are subject to change without notice.

