



# Operator Manual

## **Generator Set**

**QSK60 Engine with PowerCommand<sup>®</sup> 3.3 Control**

DQKAD (Spec F)

DQKAE (Spec F)

DQKAF (Spec F)

**CALIFORNIA**  
**Proposition 65 Warning**

**Diesel engine exhaust and some of its constituents are known to the State of California to cause cancer, birth defects, and other reproductive harm.**

# Table of Contents

---

1. IMPORTANT SAFETY INSTRUCTIONS .....	1
1.1 Warning, Caution, and Note Styles Used in This Manual .....	1
1.2 General Information .....	1
1.2.1 General Safety Precautions .....	2
1.3 Generator Set Safety Code .....	5
1.3.1 Moving Parts Can Cause Severe Personal Injury or Death .....	5
1.3.2 Positioning of Generator Set - Open Sets .....	5
1.4 Electrical Shocks and Arc Flashes Can Cause Severe Personal Injury or Death.....	6
1.4.1 AC Supply and Isolation.....	6
1.4.2 Medium Voltage Equipment (601 V to 15 kV - U.S. and Canada) .....	6
1.5 Fuel and Fumes Are Flammable .....	6
1.5.1 Spillage .....	7
1.5.2 Fluid Containment.....	7
1.5.3 Do Not Operate in Flammable and Explosive Environments .....	7
1.6 Exhaust Gases Are Deadly.....	7
1.6.1 Exhaust Precautions .....	7
1.7 Earth Ground Connection .....	8
2. INTRODUCTION.....	9
2.1 About This Manual.....	9
2.2 Schedule of Abbreviations .....	9
2.3 Related Literature .....	11
2.3.1 Further Information - Literature .....	11
2.4 After Sales Services.....	12
2.4.1 Maintenance.....	12
2.4.2 Warranty.....	12
2.4.3 How to Obtain Service .....	12
3. SYSTEM OVERVIEW .....	15
3.1 Generator Set Identification .....	15
3.1.1 Nameplate.....	15
3.1.2 Generator Set Components .....	15
3.2 Generator Set Rating.....	17
3.3 Engine.....	17
3.3.1 Generator Set Performance Data .....	18
3.4 Sensors.....	19
3.5 Pyrometers - Engine Exhaust .....	19
3.5.1 Pyrometer Position.....	19
3.6 Heaters .....	19
3.6.1 Heater Supply and Isolation.....	19
3.7 Air Cleaner.....	20
3.7.1 Normal Duty Air Cleaner .....	20

---

3.8	Prelube Feature .....	21
3.9	System Options.....	23
3.9.1	Heavy Duty Air Cleaner .....	23
3.9.2	Alarm Module .....	24
3.9.3	PowerCommand Universal Annunciator .....	25
3.9.4	Mains (Utility) Powered Battery Charger.....	26
3.9.5	Oil Sampling Valve Introduction.....	27
3.9.6	Circuit Breaker .....	27
3.9.7	Coolant Heater .....	27
3.9.8	Fuel Filters .....	28
3.9.9	Oil Sampling Valve Introduction.....	30
4.	CONTROL SYSTEM - POWERCOMMAND 3.3.....	31
4.1	Control System Description .....	31
4.1.1	Control System Panel .....	32
4.1.2	Operating Modes.....	32
4.1.3	Power On and Sleep Modes.....	35
4.1.4	Hour Meter .....	36
4.2	Operator Panel.....	36
4.2.1	Selection Buttons .....	37
4.2.2	Default Settings.....	38
4.2.3	Lamp Indicators.....	38
4.2.4	Lamp (LED) Test Button .....	38
4.2.5	Reset Button .....	38
4.2.6	CB Open Button .....	39
4.2.7	CB Closed Button .....	39
4.2.8	Graphical Display and Buttons.....	39
4.3	Operator Panel - Initial Operator Menu .....	42
4.3.1	Initial Menu Data .....	42
4.4	Operator Panel - Generator Set Data Operator Menu.....	44
4.4.1	Generator Set Data.....	44
4.5	Operator Panel - Engine Data Operator Menu .....	46
4.5.1	Engine Data .....	46
4.5.2	History/About Menu.....	48
4.6	Operator Panel - Alternator Data Operator Menu.....	51
4.6.1	Alternator Data.....	51
4.7	Operator Panel - Faults and Warnings Menus .....	53
4.7.1	Fault Menu .....	53
4.7.2	Fault Messages.....	55
4.7.3	Fault Acknowledgement.....	55
4.7.4	Warning Fault Menu.....	55
4.7.5	Faults History Data Operator Menu .....	57
4.8	Operator Panel - Adjust Menu .....	59
4.9	Operator Panel - Genset Setup Data Operator Menu .....	61
4.10	Operator Panel - Paralleling Status Menu .....	62
4.11	Operator Panel - Paralleling/Basic Setup Menu .....	70

---

4.12 Selecting Operating Modes.....	74
4.12.1 Passwords and Mode Change Access .....	74
4.12.2 Selecting Manual Run Mode.....	75
4.12.3 Selecting Auto Mode.....	75
4.12.4 Selecting Off Mode .....	76
5. OPERATION - POWERCOMMAND 3.3 .....	77
5.1 Safety.....	77
5.2 Introduction .....	77
5.3 Maintenance .....	78
5.4 Operating Recommendations .....	78
5.4.1 Running-in.....	78
5.4.2 No Load Operation.....	78
5.4.3 Exercise Period.....	78
5.4.4 Low Operating Temperatures .....	78
5.4.5 High Operating Temperatures .....	79
5.4.6 Operating Conditions .....	79
5.4.7 De-Rating Factors.....	80
5.5 Generator Set Operation.....	81
5.5.1 Sequence of Operation .....	81
5.6 Before Starting .....	81
5.6.1 Initial Pre-Start Checks .....	82
5.6.2 Operator's Pre-Start Checks.....	83
5.6.3 Starting at Operator Panel (Manual Run Mode) .....	85
5.6.4 Starting from Remote Location (Auto Mode) .....	85
5.6.5 Cold Starting with Loads.....	86
5.7 Stopping.....	87
5.7.1 Stopping at the Operator Panel (Manual Mode).....	87
5.7.2 Stopping from Operator Panel (Auto Mode) .....	87
5.7.3 Stopping from Remote Location (Auto Mode) .....	88
5.7.4 Code 1433 or 1434 - Emergency Stop .....	88
5.8 Paralleling Operation .....	89
5.8.1 Speed and Voltage Matching.....	89
5.8.2 Operation When in Parallel .....	89
5.8.3 Generator Set Application Type.....	90
5.8.4 Standalone Application .....	91
5.8.5 Synchronize Only .....	92
5.8.6 Isolated Bus Only.....	92
5.8.7 Conditions for Each Paralleling State .....	94
6. MAINTENANCE .....	103
6.1 Locking the Generator Set Out of Service.....	104
6.1.1 Immobilizing for Safe Working .....	104
6.2 Periodic Maintenance .....	105
6.2.1 Periodic Maintenance Schedule .....	106
6.3 Maintenance Procedures - Daily or When Refueling.....	111
6.3.1 General Information .....	111

6.3.2 Engine Operation Report .....	112
6.3.3 Generator Set Long Term Storage .....	112
6.4 Generator Set Long Term Storage .....	112
6.5 Cooling System.....	112
6.5.1 Coolant Level - Check.....	113
6.5.2 Low Coolant Level Sender.....	114
6.5.3 Cooling Fan - Inspection .....	114
6.5.4 Drive Belt - Inspection.....	115
6.5.5 Radiator Check .....	116
6.5.6 Cooling System Maintenance .....	117
6.6 Engine Oil .....	122
6.6.1 Engine Oil Level Check.....	122
6.6.2 Oil Sampling Valve.....	124
6.7 Fuel System .....	125
6.7.1 Fuel Level .....	126
6.7.2 Fuel/Water Separator Drain .....	126
6.8 Fuel Filter Maintenance .....	127
6.8.1 Fuel Filters - Drain .....	127
6.8.2 Fuel Filters - Element Removal .....	128
6.8.3 Fuel Filters - Element Removal .....	129
6.8.4 Fuel Filter - Element Replacement .....	131
6.9 Hoses and Fuel Lines - Check .....	132
6.10 Air Intake System.....	132
6.10.1 Air Cleaner Service Indicator .....	132
6.10.2 Normal Duty Air Cleaner .....	133
6.10.3 Heavy Duty Air Cleaner .....	134
6.11 Exhaust System .....	136
6.12 Generator Set Output - AC Electric System .....	136
6.13 DC Electrical System .....	137
6.14 Batteries.....	137
6.14.1 Storage.....	138
6.14.2 Safety Precautions.....	138
6.14.3 Battery Maintenance .....	139
6.14.4 Electrolyte - Specific Gravity and Temperature .....	141
6.14.5 Battery Replacement.....	143
6.14.6 Battery Type Specification .....	144
6.14.7 Battery Fault Finding.....	144
7. TROUBLESHOOTING .....	147
7.1 Control System .....	147
7.2 Safety Considerations.....	147
7.3 Fault Finding .....	148
7.4 Status Indicators - PowerCommand 3.3.....	149
7.4.1 Not in Auto .....	149
7.4.2 Remote Start .....	149
7.4.3 Warning .....	149

---

7.4.4 Shutdown Status .....	149
7.4.5 Generator Set Running Lamp .....	149
7.5 Fault/Status Codes - PowerCommand 3.3 .....	150
7.5.1 Fault Messages.....	150
7.5.2 Fault Acknowledgement.....	150
7.5.3 Fault Codes - PowerCommand 3.3 .....	150
7.5.4 Troubleshooting Procedures for Fault Codes .....	189
7.6 Line Circuit Breaker .....	193
7.6.1 Circuit Breaker Location.....	194
8. BATTERY CHARGER.....	195
8.1 Battery Charger - 15 Amp/12 Volt and 12 Amp/24 Volt.....	195
8.1.1 Battery Charger Control Panel.....	196
8.1.2 Battery Charger Configuration .....	197
8.1.3 Battery Temperature Sensor.....	198
8.2 Battery Circuits.....	198
9. MANUFACTURING FACILITIES.....	199

This page is intentionally blank.

# 1 IMPORTANT SAFETY INSTRUCTIONS

---

SAVE THESE INSTRUCTIONS. This manual contains important instructions that should be followed during installation and maintenance of the generator set and batteries.

Safe and efficient operation can be achieved only if the equipment is properly operated and maintained. Many accidents are caused by failure to follow fundamental rules and precautions.

## 1.1 Warning, Caution, and Note Styles Used in This Manual

The following safety styles and symbols found throughout this manual indicate potentially hazardous conditions to the operator, service personnel, or equipment.

 <b>DANGER</b>
<i>Indicates a hazardous situation that, if not avoided, will result in death or serious injury.</i>

 <b>WARNING</b>
<i>Indicates a hazardous situation that, if not avoided, could result in death or serious injury.</i>

 <b>CAUTION</b>
<i>Indicates a hazardous situation that, if not avoided, could result in minor or moderate injury.</i>

<b>NOTICE</b>
Indicates information considered important, but not hazard-related (e.g., messages relating to property damage).

## 1.2 General Information

This manual should form part of the documentation package supplied by Cummins with specific generator sets. In the event that this manual has been supplied in isolation, please contact your authorized distributor.

<b>NOTICE</b>
<b>It is in the operator's interest to read and understand all warnings and cautions contained within the documentation relevant to the generator set, its operation and daily maintenance.</b>

## 1.2.1 General Safety Precautions

### WARNING

#### ***Hot Pressurized Liquid***

***Contact with hot liquid can cause severe burns.***

***Do not open the pressure cap while the engine is running. Let the engine cool down before removing the cap. Turn the cap slowly and do not open it fully until the pressure has been relieved.***

### WARNING

#### ***Moving Parts***

***Moving parts can cause severe personal injury.***

***Use extreme caution around moving parts. All guards must be properly fastened to prevent unintended contact.***

### WARNING

#### ***Toxic Hazard***

***Used engine oils have been identified by some state and federal agencies to cause cancer or reproductive toxicity.***

***Do not ingest, breathe the fumes, or contact used oil when checking or changing engine oil. Wear protective gloves and face guard.***

### WARNING

#### ***Electrical Generating Equipment***

***Incorrect operation can cause severe personal injury or death.***

***Do not operate equipment when fatigued, or after consuming any alcohol or drug.***

### WARNING

#### ***Toxic Gases***

***Substances in exhaust gases have been identified by some state and federal agencies to cause cancer or reproductive toxicity.***

***Do not breathe in or come into contact with exhaust gases.***

### WARNING

#### ***Combustible Liquid***

***Ignition of combustible liquids is a fire or explosion hazard which can cause severe burns or death.***

***Do not store fuel, cleaners, oil, etc., near the generator set.***

### WARNING

#### ***High Noise Level***

***Generator sets in operation emit noise, which can cause hearing damage.***

***Wear appropriate ear protection at all times.***

**⚠ WARNING****Hot Surfaces**

*Contact with hot surfaces can cause severe burns.*

*The unit is to be installed so that the risk of hot surface contact by people is minimized. Wear appropriate PPE when working on hot equipment and avoid contact with hot surfaces.*

**⚠ WARNING****Electrical Generating Equipment**

*Incorrect operation and maintenance can result in severe personal injury or death.*

*Make sure that only suitably trained and experienced service personnel perform electrical and/or mechanical service.*

**⚠ WARNING****Toxic Hazard**

*Ethylene glycol, used as an engine coolant, is toxic to humans and animals.*

*Wear appropriate PPE. Clean up coolant spills and dispose of used coolant in accordance with local environmental regulations.*

**⚠ WARNING****Combustible Liquid**

*Ignition of combustible liquids is a fire or explosion hazard which can cause severe burns or death.*

*Do not use combustible liquids like ether.*

**⚠ WARNING****Automated Machinery**

*Accidental or remote starting of the generator set can cause severe personal injury or death.*

*Isolate all auxiliary supplies and use an insulated wrench to disconnect the starting battery cables (negative [-] first).*

**⚠ WARNING****Fire Hazard**

*Materials drawn into the generator set are a fire hazard. Fire can cause severe burns or death.*

*Make sure the generator set is mounted in a manner to prevent combustible materials from accumulating under the unit.*

**⚠ WARNING****Fire Hazard**

*Accumulated grease and oil are a fire hazard. Fire can cause severe burns or death.*

*Keep the generator set and the surrounding area clean and free from obstructions. Repair oil leaks promptly.*

**⚠ WARNING****Fall Hazard**

*Falls can result in severe personal injury or death.*

*Make sure that suitable equipment for performing tasks at height are used in accordance with local guidelines and legislation.*

**⚠ WARNING****Fire Hazard**

*Materials drawn into the generator set are a fire hazard. Fire can cause severe burns or death.*

*Keep the generator set and the surrounding area clean and free from obstructions.*

**⚠ WARNING****Pressurized System**

*Pressurized systems can rupture/leak which can result in severe personal injury or death.*

*Use appropriate lock out/tag out safety procedures to isolate from all energy sources before performing any service tasks. Use PPE.*

**⚠ WARNING****Confined Areas**

*Confined spaces or areas with restricted access or potential to entrap can cause severe personal injury or death.*

*Use appropriate lock out/tag out safety procedures to isolate from all energy sources. Use PPE. Follow site specific lone worker protocols/permits to work.*

**⚠ CAUTION****Manual Handling Heavy Objects**

*Handling heavy objects can cause severe personal injury.*

*Use appropriate lifting equipment and perform tasks with two people where doing so would make completion of the task safe.*

**⚠ CAUTION****Power Tools and Hand Tools**

*Tools can cause cuts, abrasions, bruising, puncture injuries.*

*Only trained and experienced personnel should use power tools and hand tools. Use PPE.*

**⚠ CAUTION****Sharp Edges and Sharp Points**

*Projecting corners/parts may cause cuts, abrasions and other personal injury.*

*Use PPE. Be aware of sharp edges and corners/sharp points. Cover/protect them.*

**NOTICE**

**Keep multi-type ABC fire extinguishers close by. Class A fires involve ordinary combustible materials such as wood and cloth. Class B fires involve combustible and flammable liquid fuels and gaseous fuels. Class C fires involve live electrical equipment. (Refer to NFPA No. 10 in the applicable region.)**

**NOTICE**

Before performing maintenance and service procedures on enclosed generator sets, make sure the service access doors are secured open.

**NOTICE**

Stepping on the generator set can cause parts to bend or break, leading to electrical shorts, or to fuel leaks, coolant leaks, or exhaust leaks. Do not step on the generator set when entering or leaving the generator set room.

**NOTICE**

Remove fuel from subbase fuel tank before conducting any hot work.

## 1.3 Generator Set Safety Code

Before operating the generator set, read the manuals and become familiar with them and the equipment. Safe and efficient operation can be achieved only if the equipment is properly operated and maintained. Many accidents are caused by failure to follow fundamental rules and precautions.

**⚠ WARNING*****Electrical Generating Equipment***

***Incorrect operation and maintenance can result in severe personal injury or death.***

***Read and follow all Safety Precautions, Warnings, and Cautions throughout this manual and the documentation supplied with the generator set.***

### 1.3.1 Moving Parts Can Cause Severe Personal Injury or Death

- Keep hands, clothing, and jewelry away from moving parts.
- Before starting work on the generator set, disconnect the battery charger from its AC source, then disconnect the starting batteries using an insulated wrench, negative (–) cable first. This will prevent accidental starting.
- Make sure that fasteners on the generator set are secure. Tighten supports and clamps; keep guards in position over fans, drive belts, etc.
- Do not wear loose clothing or jewelry in the vicinity of moving parts or while working on electrical equipment. Loose clothing and jewelry can become caught in moving parts.
- If any adjustments must be made while the unit is running, use extreme caution around hot manifolds, moving parts, etc.

### 1.3.2 Positioning of Generator Set - Open Sets

The area for positioning the set should be adequate and level, and the area immediately around the set must be free of any flammable material.

## 1.4 Electrical Shocks and Arc Flashes Can Cause Severe Personal Injury or Death

- Only qualified service personnel certified and authorized to work on power circuits should work on exposed energized power circuits.
- All relevant service material must be available for any electrical work performed by certified service personnel.
- Exposure to energized power circuits with potentials of 50 VAC or 75 VDC or higher poses a significant risk of electrical shock and electrical arc flash.
- Refer to standard NFPA 70E, or equivalent safety standards in corresponding regions, for details of the dangers involved and for safety requirements.

### 1.4.1 AC Supply and Isolation

#### NOTICE

Local electrical codes and regulations (for example, *BS EN 12601:2010 Reciprocating internal combustion engine driven generating sets*) may require the installation of a disconnect means for the generator set, either on the generator set or where the generator set conductors enter a facility.

#### NOTICE

The AC supply must have the correct over current and earth fault protection according to local electrical codes and regulations. This equipment must be earthed (grounded).

It is the sole responsibility of the customer to provide AC power conductors for connection to load devices and the means to isolate the AC input to the terminal box; these must comply with local electrical codes and regulations. Refer to the wiring diagram supplied with the generator set.

The disconnecting device is not provided as part of the generator set, and Cummins accepts no responsibility for providing the means of isolation.

### 1.4.2 Medium Voltage Equipment (601 V to 15 kV - U.S. and Canada)

- Medium voltage acts differently than low voltage. Special equipment and training is required to work on or around medium voltage equipment. Operation and maintenance must be done only by persons trained and experienced to work on such devices. Improper use or procedures will result in severe personal injury or death.
- Do not work on energized equipment. Unauthorized personnel must not be permitted near energized equipment. Due to the nature of medium voltage electrical equipment, induced voltage remains even after the equipment is disconnected from the power source. Plan the time for maintenance with authorized personnel so that the equipment can be de-energized and safely grounded.

## 1.5 Fuel and Fumes Are Flammable

Fire, explosion, and personal injury or death can result from improper practices.

- Do not fill fuel tanks while the engine is running unless the tanks are outside the engine compartment. Fuel contact with hot engine or exhaust is a potential fire hazard.

- Do not permit any flame, cigarette, pilot light, spark, arcing equipment, or other ignition source near the generator set or fuel tank.
- Fuel lines must be adequately secured and free of leaks. Fuel connection at the engine should be made with an approved flexible line. Do not use copper piping on flexible lines as copper will become brittle if continuously vibrated or repeatedly bent.
- Make sure all fuel supplies have a positive shutoff valve.
- Make sure the battery area has been well-ventilated prior to servicing near it. Lead-acid batteries emit a highly explosive hydrogen gas that can be ignited by arcing, sparking, smoking, etc.

### 1.5.1 Spillage

Any spillage that occurs during fueling, oil top-off, or oil change must be cleaned up before starting the generator set.

### 1.5.2 Fluid Containment

#### NOTICE

**Where spillage containment is not part of a Cummins supply, it is the responsibility of the installer to provide the necessary containment to prevent contamination of the environment, especially water courses and sources.**

If fluid containment is incorporated into the bedframe, it must be inspected at regular intervals. Any liquid present should be drained out and disposed of in line with local health and safety regulations. Failure to perform this action may result in spillage of liquids which could contaminate the surrounding area.

Any other fluid containment area must also be checked and emptied, as described above.

### 1.5.3 Do Not Operate in Flammable and Explosive Environments

Flammable vapor can cause an engine to over speed and become difficult to stop, resulting in possible fire, explosion, severe personal injury, and death. Do not operate a generator set where a flammable vapor environment can be created, unless the generator set is equipped with an automatic safety device to block the air intake and stop the engine. The owners and operators of the generator set are solely responsible for operating the generator set safely. Contact your authorized Cummins distributor for more information.

## 1.6 Exhaust Gases Are Deadly

- Provide an adequate exhaust system to properly expel discharged gases away from enclosed or sheltered areas, and areas where individuals are likely to congregate. Visually and audibly inspect the exhaust system daily for leaks per the maintenance schedule. Make sure that exhaust manifolds are secured and not warped. Do not use exhaust gases to heat a compartment.
- Make sure the unit is well ventilated.

### 1.6.1 Exhaust Precautions

#### WARNING

##### **Hot Exhaust Gases**

**Contact with hot exhaust gases can cause severe burns.**

**Wear personal protective equipment when working on equipment.**

**⚠ WARNING****Hot Surfaces**

**Contact with hot surfaces can cause severe burns.**

**The unit is to be installed so that the risk of hot surface contact by people is minimized. Wear appropriate PPE when working on hot equipment and avoid contact with hot surfaces.**

**⚠ WARNING****Toxic Gases**

**Inhalation of exhaust gases can cause asphyxiation and death.**

**Pipe exhaust gas outside and away from windows, doors, or other inlets to buildings. Do not allow exhaust gas to accumulate in habitable areas.**

**⚠ WARNING****Fire Hazard**

**Contaminated insulation is a fire hazard. Fire can cause severe burns or death.**

**Remove any contaminated insulation and dispose of it in accordance with local regulations.**

The exhaust outlet may be sited at the top or bottom of the generator set. Make sure that the exhaust outlet is not obstructed. Personnel using this equipment must be made aware of the exhaust position. Position the exhaust away from flammable materials - in the case of exhaust outlets at the bottom, make sure that vegetation is removed from the vicinity of the exhaust.

The exhaust pipes may have some insulating covers fitted. If these covers become contaminated they must be replaced before the generator set is run.

To minimize the risk of fire, make sure the following steps are observed:

- Make sure that the engine is allowed to cool thoroughly before performing maintenance or operation tasks.
- Clean the exhaust pipe thoroughly.

## 1.7 Earth Ground Connection

The neutral of the generator set may be required to be bonded to earth ground at the generator set location, or at a remote location, depending on system design requirements. Consult the engineering drawings for the facility or a qualified electrical design engineer for proper installation.

**NOTICE**

**The end user is responsible to make sure that the ground connection point surface area is clean and free of rust before making a connection.**

**NOTICE**

**The end user is responsible for making sure that an earthing arrangement that is compliant with local conditions is established and tested before the equipment is used.**

## 2 Introduction

---

### WARNING

#### **Hazardous Voltage**

**Contact with high voltages can cause severe electrical shock, burns, or death.**

**Make sure that only a trained and experienced electrician makes generator set electrical output connections, in accordance with the installation instructions and all applicable codes.**

### WARNING

#### **Electrical Generating Equipment**

**Faulty electrical generating equipment can cause severe personal injury or death.**

**Generator sets must be installed, certified, and operated by trained and experienced persons in accordance with the installation instructions and all applicable codes.**

## 2.1 About This Manual

The purpose of this manual is to provide the users with accurate, general information. It is for guidance and assistance with recommendations for correct and safe procedures. Cummins cannot accept any liability whatsoever for problems arising as a result of following recommendations in this manual.

The information contained within the manual is based on information available at the time of going to print. In line with Cummins policy of continuous development and improvement, information may change at any time without notice. The users should therefore make sure that before commencing any work, they have the latest information available. The latest version of this manual is available on QuickServe Online (<https://quickserve.cummins.com>).

Users are respectfully advised that, in the interests of good practice and safety, it is their responsibility to employ competent persons to carry out any installation work. Consult your authorized distributor for further installation information. It is essential that the utmost care is taken with the application, installation, and operation of any engine due to their potentially hazardous nature. Careful reference should also be made to other Cummins literature. A generator set must be operated and maintained properly for safe and reliable operation.

For further assistance, contact your authorized distributor.

## 2.2 Schedule of Abbreviations

This list is not exhaustive. For example, it does not identify units of measure or acronyms that appear only in parameters, event/fault names, or part/accessory names.

ABBR.	DESCRIPTION	ABBR.	DESCRIPTION
AC	Alternating Current	LED	Light-emitting Diode
AMP	AMP, Inc., part of Tyco Electronics	LTS	Long Term Storage
ANSI	American National Standards Institute	LVRT	Low Voltage Ride Through
ASOV	Automatic Shut Off Valve	MFM	Multifunction Monitor

<b>ABBR.</b>	<b>DESCRIPTION</b>	<b>ABBR.</b>	<b>DESCRIPTION</b>
ASTM	American Society for Testing and Materials (ASTM International)	Mil Std	Military Standard
ATS	Automatic Transfer Switch	MLD	Masterless Load Demand
AVR	Automatic Voltage Regulator	NC	Normally Closed
AWG	American Wire Gauge	NC	Not Connected
CAN	Controlled Area Network	NFPA	National Fire Protection Agency
CB	Circuit Breaker	NO	Normally Open
CE	Conformité Européenne	NWF	Network Failure
CFM	Cubic Feet per Minute	OEM	Original Equipment Manufacturer
CGT	Cummins Generator Technologies	OOR	Out of Range
CMM	Cubic Meters per Minute	OORH / ORH	Out of Range High
CT	Current Transformer	OORL / ORL	Out of Range Low
D-AVR	Digital Automatic Voltage Regulator	PB	Push Button
DC	Direct Current	PCC	PowerCommand® Control
DEF	Diesel Exhaust Fluid	PGI	Power Generation Interface
DPF	Diesel Particulate Filter	PGN	Parameter Group Number
ECM	Engine Control Module	PI	Proportional/Integral
ECS	Engine Control System	PID	Proportional / Integral / Derivative
EMI	Electromagnetic interference	PLC	Programmable Logic Controller
EN	European Standard	PMG	Permanent Magnet Generator
EPS	Engine Protection System	PPE	Personal Protective Equipment
E-Stop	Emergency Stop	PT	Potential Transformer
FAE	Full Authority Electronic	PTC	Power Transfer Control
FMI	Failure Mode Identifier	PWM	Pulse-width Modulation
FRT	Fault Ride Through	RFI	Radio Frequency Interference
FSO	Fuel Shutoff	RH	Relative Humidity
Genset	Generator Set	RMS	Root Mean Square
GCP	Generator Control Panel	RTU	Remote Terminal Unit
GND	Ground	SAE	Society of Automotive Engineers
LCT	Low Coolant Temperature	SCR	Selective Catalytic Reduction
HMI	Human-machine Interface	SPN	Suspect Parameter Number
IC	Integrated Circuit	SWL	Safe Working Load
ISO	International Organization for Standardization	SW_B+	Switched B+

ABBR.	DESCRIPTION	ABBR.	DESCRIPTION
LBNG	Lean-burn Natural Gas	UL	Underwriters Laboratories
LCD	Liquid Crystal Display	UPS	Uninterruptible Power Supply
		VPS	Valve Proving System

## 2.3 Related Literature

Before any attempt is made to operate the generator set, the operator should take time to read all of the manuals supplied with the generator set and familiarize themselves with the warnings and operating procedures.

### NOTICE

**A generator set must be operated and maintained properly if you are to expect safe and reliable operation. The Operator manual includes a maintenance schedule and a troubleshooting guide. The Health and Safety manual must be read in conjunction with this manual for the safe operation of the generator set:**

- Health and Safety Manual (0908-0110)

The relevant manuals appropriate to your generator set are also available, the documents below are in English:

- Operator Manual for DQKAD, DQKAE, and DQKAF Generator Sets with PowerCommand 3.3 Controller (A055E000)
- Installation Manual DQKAD, DQKAE, and DQKAF Generator Sets (A055D999)
- Service Manual for DQKAD, DQKAE, and DQKAF Generator Sets (A056H611)
- Recommended Spares List (RSL) for DQKAD Generator Sets (A056A610)
- Recommended Spares List (RSL) for DQKAE Generator Sets (A056A611)
- Recommended Spares List (RSL) for DQKAF Generator Sets (A056A612)
- Parts Manual for DQKAD, DQKAE, and DQKAF Generator Sets (A034V858)
- *Standard Repair Times - FD Family (A029F346)*
- Fuels for Cummins Engines Service Bulletin (3379001)
- Universal Annunciator Owner Manual (0900-0301)
- Service Tool Manual (A043D529)
- Failure Code Manual (F1115C)
- Engineering Application Manual *T-030: Liquid Cooled Generator Sets (A040S369)*
- Engine Operation & Maintenance Manual for QSK60 (3666260)
- Warranty Administration Manual (4021290)
- Global Commercial Warranty Statement (A028U870)

### 2.3.1 Further Information - Literature

Contact your authorized distributor for more information regarding related literature for this product.

## 2.4 After Sales Services

Cummins offers a full range of maintenance and warranty services.

### 2.4.1 Maintenance

#### WARNING

##### ***Electrical Generating Equipment***

***Incorrect operation and maintenance can result in severe personal injury or death.***

***Make sure that only suitably trained and experienced service personnel perform electrical and/or mechanical service.***

For expert generator set service at regular intervals, contact your local distributor. Each local distributor offers a complete maintenance contract package covering all items subject to routine maintenance, including a detailed report on the condition of the generator set. In addition, this can be linked to a 24-hour call-out arrangement, providing year-round assistance if necessary. Specialist engineers are available to maintain optimum performance levels from generator sets. Maintenance tasks should only be undertaken by trained and experienced technicians provided by your authorized distributor.

### 2.4.2 Warranty

For details of the warranty coverage for your generator set, refer to the Global Commercial Warranty Statement listed in the Related Literature section.

In the event of a breakdown, prompt assistance can normally be given by factory trained service technicians with facilities to undertake all minor and many major repairs to equipment on site.

Extended warranty coverage is also available.

For further warranty details, contact your authorized service provider.

#### NOTICE

**Damage caused by failure to follow the manufacturer's recommendations will not be covered by the warranty. Please contact your authorized service provider.**

#### 2.4.2.1 Warranty Limitations

For details of the warranty limitations for your generator set, refer to the warranty statement applicable to the generator set.

### 2.4.3 How to Obtain Service

When a product requires servicing, contact the nearest Cummins service provider. To locate the distributor, go to [www.cummins.com/support](http://www.cummins.com/support) and select Sales and Service Locator. When contacting the service provider, always supply the complete model, specification, and serial number as shown on the nameplate.

#### 2.4.3.1 Locating a Distributor

##### **In the U.S. and Canada**

To easily locate the nearest certified distributor/dealer for Cummins generator sets in your area, or for more information, contact us at 1-800-CUMMINS™ (1-800-286-6467) or visit [www.cummins.com/support](http://www.cummins.com/support).

If unable to contact a distributor using the automated service, consult the Internet.

If unable to arrange a service or resolve an issue, contact the Service Manager at the nearest Cummins distributor for assistance.

When contacting the distributor, always supply the complete Model, Specification, and Serial Number as shown on the product nameplate.

**Outside the U.S. and Canada**

Refer to [www.cummins.com/support](http://www.cummins.com/support) and select Sales and Service Locator, or send an email to [ask.powergen@cummins.com](mailto:ask.powergen@cummins.com).

This page is intentionally blank.



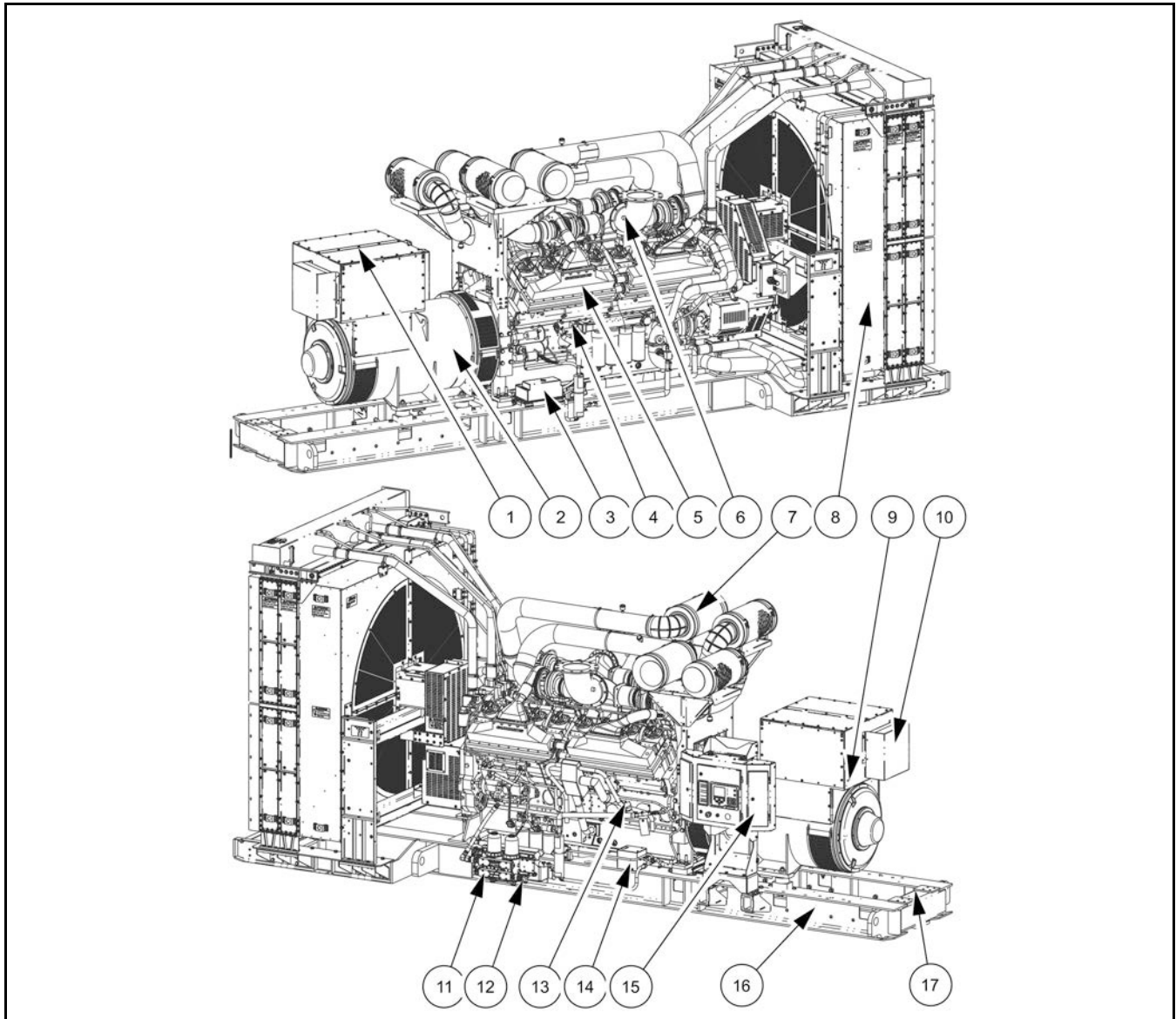

No.	Description	No.	Description	No.	Description
1	Circuit Breaker Box or Entrance Box (optional)	7	Air Cleaners	13	Oil Fill
2	Alternator	8	Radiator	14	Coolant Heater Control (optional)
3	Pre-Lube Control (optional)	9	Alternator Heater (optional)	15	Control
4	Oil Sampling Valve (optional)	10	RTD Auxiliary Box (optional)	16	Skid
5	Engine	11	Fuel Filter	17	Control (optional location)
6	Exhaust Temperature Sensor (optional)	12	Oil Drain		

**FIGURE 2. GENERATOR SET WITH CIRCUIT BREAKER BOX**

### 3.2 Generator Set Rating

Refer to the generator set nameplate for generator set rating. Refer to [Section 5.4 on page 78](#) for operation at temperatures or altitudes above those stated on the nameplate.

### 3.3 Engine

For additional engine specific information, refer to the relevant engine manual for your generator set.

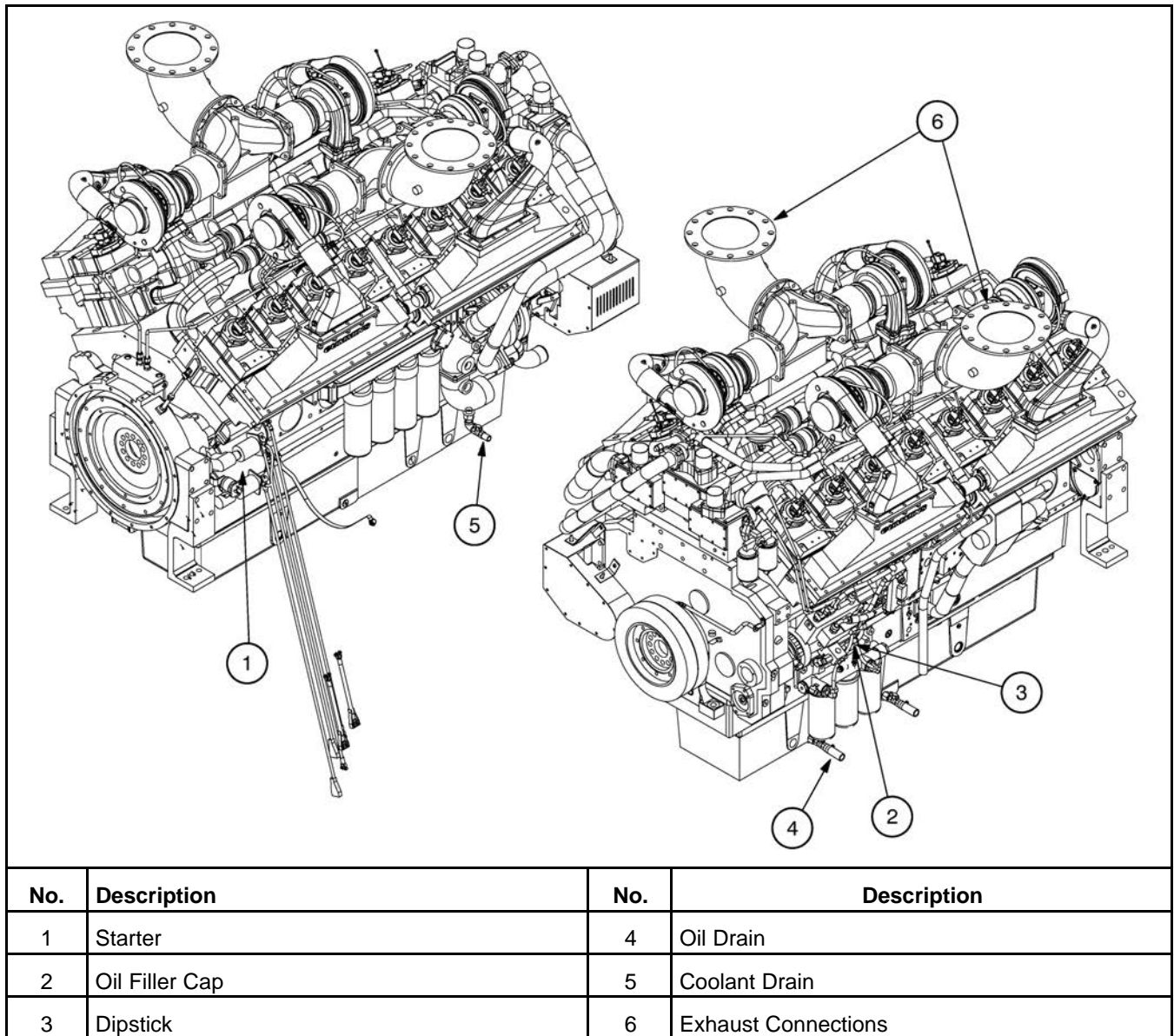

**FIGURE 3. TYPICAL QSK60 ENGINE COMPONENTS**

### 3.3.1 Generator Set Performance Data

#### 3.3.1.1 Acoustic Information

##### 3.3.1.1.1 Acoustic Information (1800 RPM)

TABLE 1. ACOUSTIC DATA (1800 RPM)

Model	DQKAD	DQKAE	DQKAF
Engine	QSK60-G6	QSK60-G6	QSK60-G14
Open Set Acoustic Data – dB(A) at 1m (based on full load) – SPL (or enclosed set with doors open)	123	125	125
High Ambient Cooling System	124	125	126
Enhanced High Ambient Cooling System	122	123	124
Remote Cooled			

For Noise Spectrum Figures, refer also to your authorized distributor.  
In line with the Cummins Inc policy of continuous improvement, these figures are subject to change.

#### 3.3.1.2 Engine Fuel Consumption - QSK60 Engine

TABLE 2. FUEL CONSUMPTION (L/HR) AT 1800 RPM (60 HZ)

Model	DQKAD	DQKAE	DQKAF
Engine	QSK60-G6 NR2	QSK60-G6 NR2	QSK60-G14 NR2
Engine Performance Data at 60Hz <sup>1</sup>	457	511	574.6

1. Standby/Full Load  
Refer to Data Sheets for other applications. In line with the Cummins inc policy of continuous improvement, these figures are subject to change.

TABLE 3. FUEL CONSUMPTION (GAL/HR) AT 1800 RPM (60 HZ)

Model	DQKAD	DQKAE	DQKAF
Engine	QSK60-G6 NR2	QSK60-G6 NR2	QSK60-G14 NR2
Engine Performance Data at 60Hz <sup>1</sup>	120.6	135	151.8

1. Standby/Full Load  
Refer to Data Sheets for other applications. In line with the Cummins Inc policy of continuous improvement, these figures are subject to change.

#### 3.3.1.3 Fuel Quality

The use of clean quality fuel is essential for the successful operation of Cummins Engines. For detailed information on fuel recommendations, refer to Service Bulletin 3379001.

### 3.4 Sensors

Various generator set parameters are measured by sensors, and the resulting signals are processed by the control board.

Engine-mounted sensors monitor a number of different systems, such as:

- Lube Oil Pressure
- Cooling System Temperature

### 3.5 Pyrometers - Engine Exhaust

A pyrometer measures engine exhaust gas temperature. A separate temperature meter is used to monitor each exhaust outlet elbow.

#### 3.5.1 Pyrometer Position

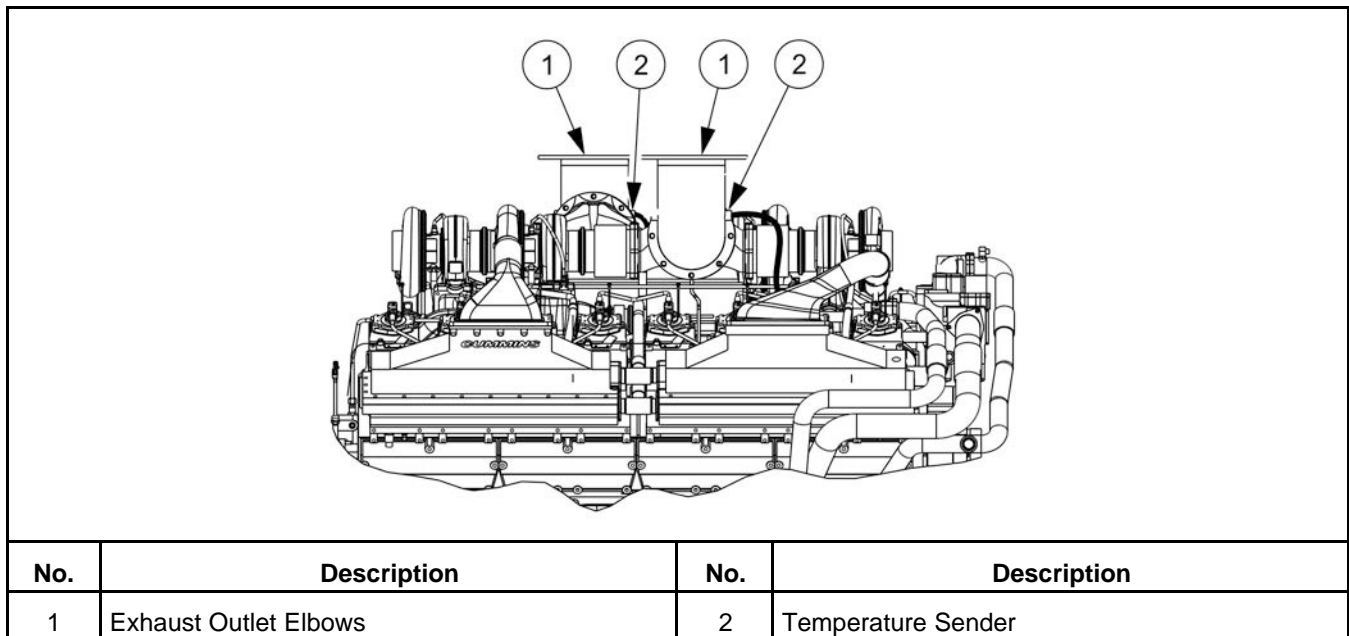

FIGURE 4. PYROMETER LOCATION

### 3.6 Heaters

#### 3.6.1 Heater Supply and Isolation

A power supply is required for the operation of the engine, coolant, and alternator heaters (if fitted).

<b>NOTICE</b>
It is the sole responsibility of the customer to provide the power supply and the means to isolate the AC input to the terminal box. Cummins accepts no responsibility for providing the means of isolation. Contact your distributor for more information.

**NOTICE**

This disconnecting device is not provided as part of the generator set.

## 3.7 Air Cleaner

An air cleaner includes an element that must be replaced periodically. Some air cleaners include a service indicator that indicates when an air cleaner element is dirty and must be replaced.

### 3.7.1 Normal Duty Air Cleaner

This shows the normal duty air cleaner. See [Section 3.9 on page 23](#) for optional air cleaners.

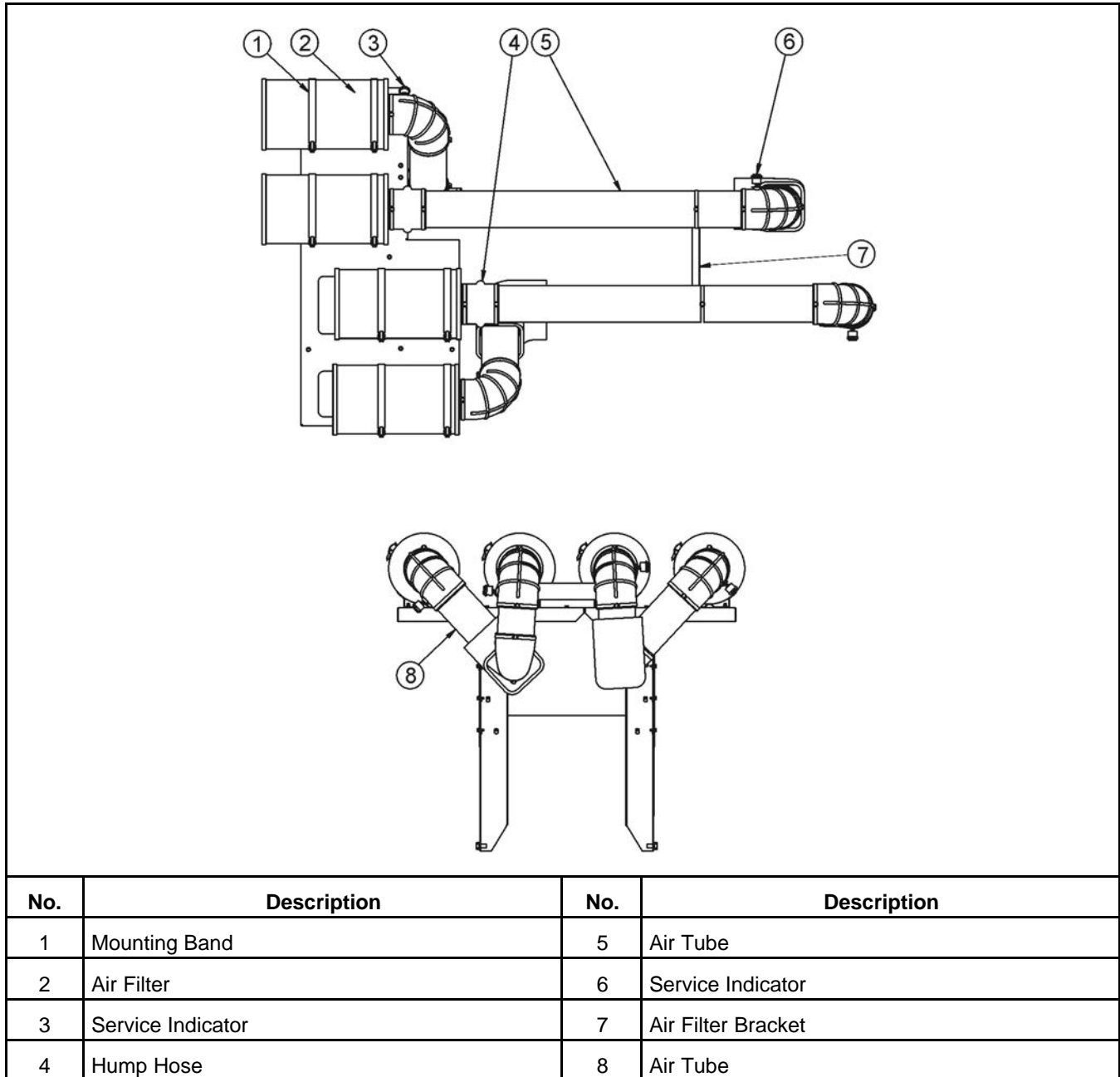

FIGURE 5. NORMAL AIR CLEANER ASSEMBLY

### 3.8 Prelube Feature

The prelube feature is designed to make sure properly lubrication is maintained during times when the generator set is not running.

---

The prelube control box is mounted on the skid and has connections to the prelube pump, the starter, the crank relay, and the prelube relay located inside the generator set control box.

- Upon powering up the generator set control, there is a 2 minute initialization delay of the prelube system. This is followed by a periodic cycle in which the prelube system is on for 40 seconds and off for 12 hours. When the prelube pump is running, the magnetic switch produces a loud noise as it provides power to the pump.
- There are two inputs that are continuously monitored.
  - Engine Crank signal (positive coil terminal on the start solenoid).
  - Engine Run signal (switched B+ of the customer connection terminal block)
- The periodic cycle is interrupted if any of the following occur.
  - The engine gets a crank signal
  - Power is taken away from the module (an E-Stop is activated)
  - The engine is running.
- If the engine gets a crank signal while the prelube pump is running, the prelube pump runs in parallel for 15 seconds. Once the 15 second timer expires, a 10 minute lock-out timer begins. If another start request occurs during the 10 minute lock-out, the pump will not run.
- If the engine is started and runs for less than 10 minutes, the 10 minute timer runs out the balance of the lock-out cycle and then the 2 minute delay begins.

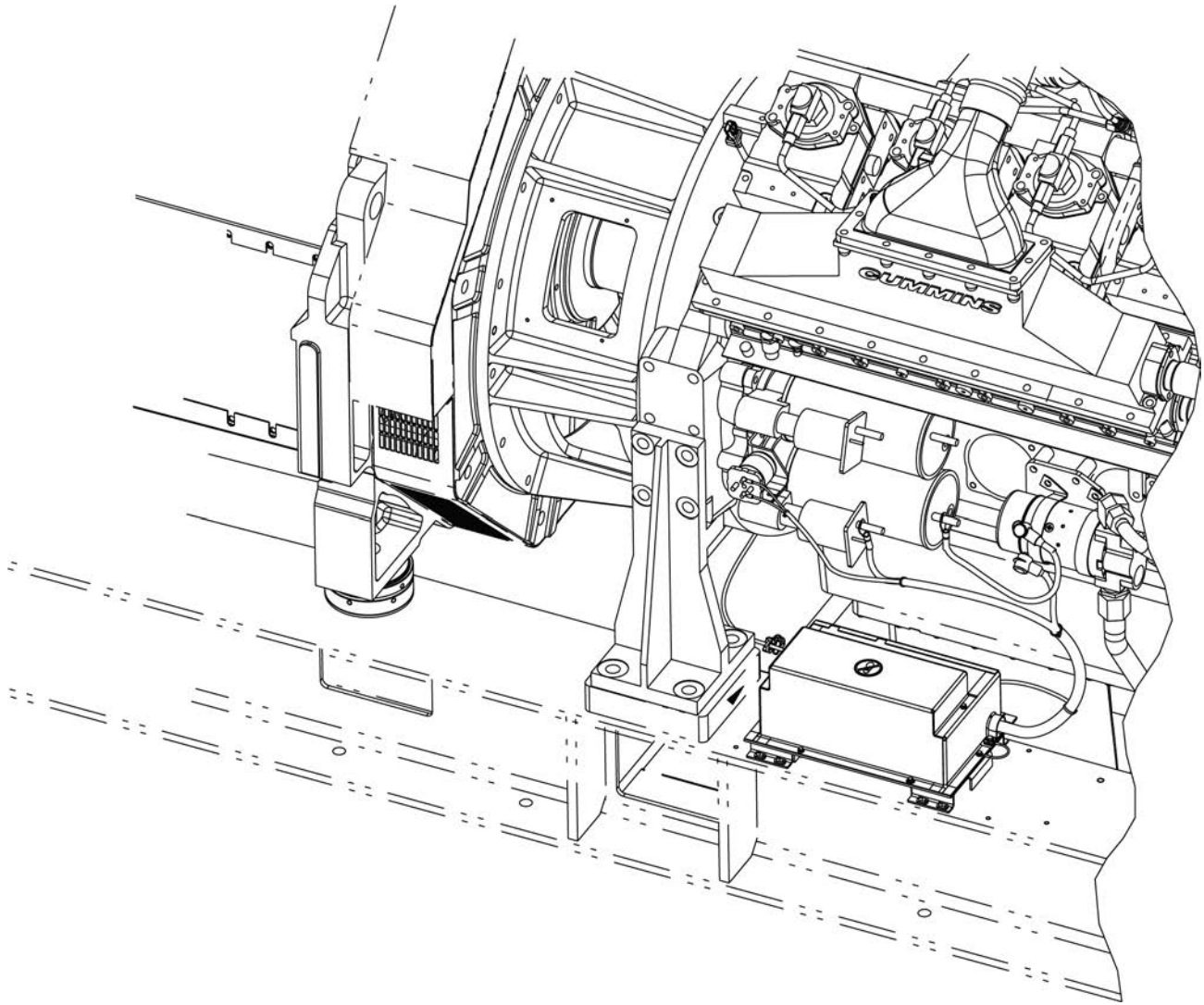

FIGURE 6. PRELUBE

## 3.9 System Options

### 3.9.1 Heavy Duty Air Cleaner

A heavy duty air cleaner is used in dusty environments. This shows the heavy duty air cleaner.

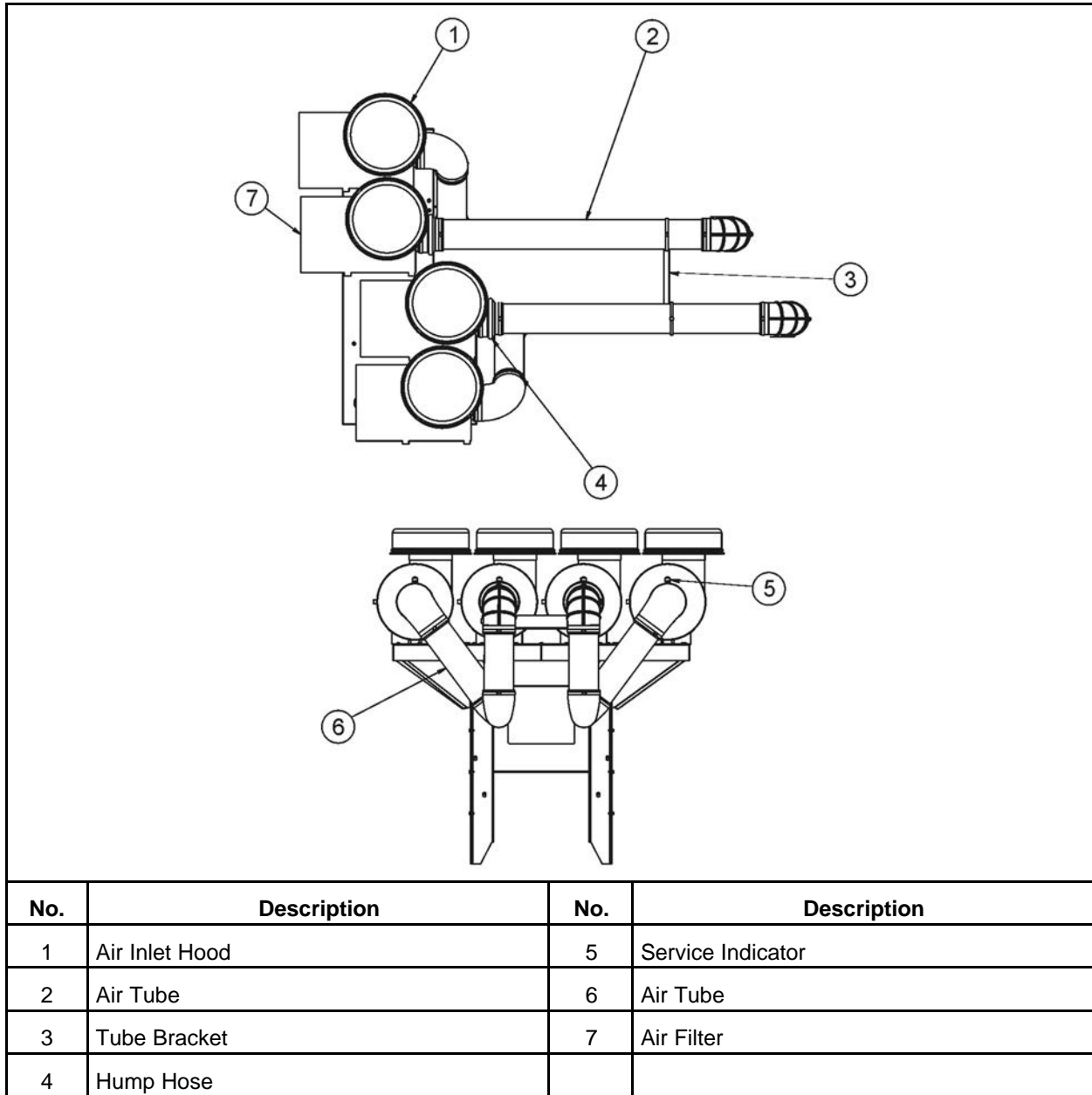

FIGURE 7. HEAVY DUTY AIR CLEANER ASSEMBLY

### 3.9.2 Alarm Module

The alarm module provides audible warnings. It includes a pushbutton switch to silence the horn. It also includes a red LED to announce an active alarm and an amber LED that indicates when the horn is silenced.

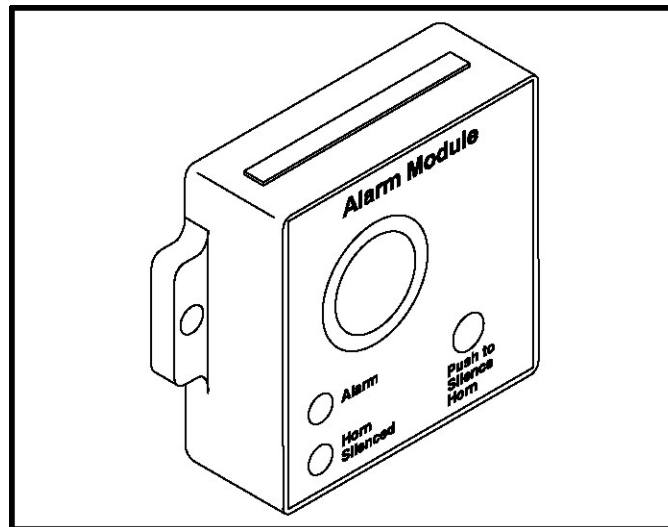

FIGURE 8. ALARM MODULE

### 3.9.3 PowerCommand Universal Annunciator

A universal annunciator provides lamps and a horn to annunciate the operating status and fault conditions of an emergency power system. It is designed for connection to either a 12 VDC or a 24 VDC control system. It can be configured to be either a positive or negative signal device.

Two versions of the PowerCommand universal annunciator are available.

- Panel Mounted
- Panel with Enclosure

The universal annunciator can communicate using either a PCCNet or a Modbus network.

Refer to the PowerCommand Universal Owners Manual for more information.

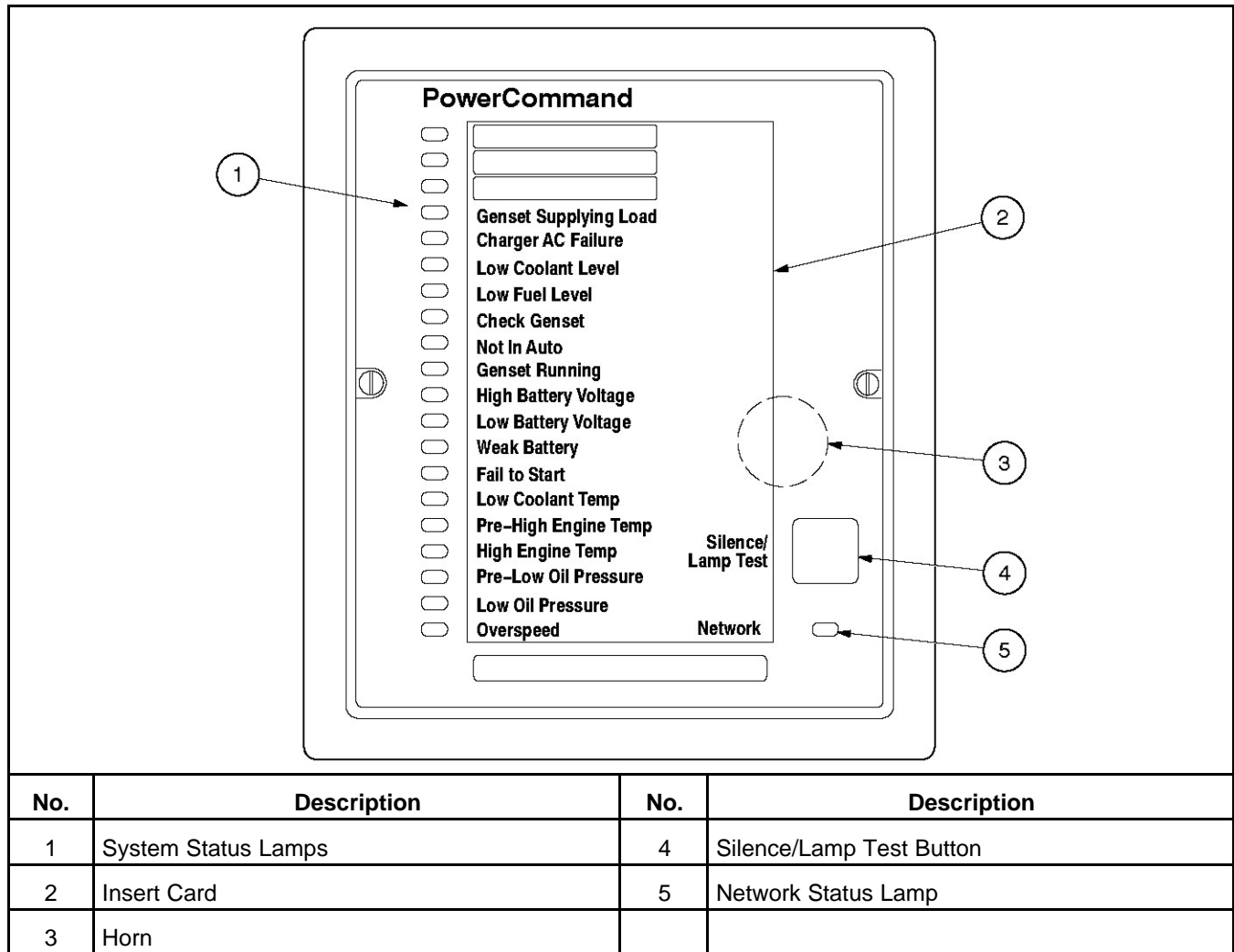

FIGURE 9. ANNUNCIATOR COMPONENTS

### 3.9.4 Mains (Utility) Powered Battery Charger

**⚠ CAUTION**

**Hazardous Voltage**  
*Contact with high voltages can cause severe electrical shock, burns, or death.*  
*Disconnect the battery charger before isolating the battery.*

This unit maintains the battery in a fully charged condition without over-charging. The unit also provides rapid charging, when necessary, at a current up to the rated output.

The charger's electronic control circuit allows the charger to be left in circuit during engine cranking and to operate in parallel with the charge alternator.

The charger will supply current to the battery system until the battery terminal voltage becomes equal to the set float voltage, at which point only a trickle charge current is present. When the battery becomes discharged due to a load being present and the terminal voltage falls, the charger will again supply current to restore the voltage of the battery to the float voltage.

---

### 3.9.5 Oil Sampling Valve Introduction

The oil sampling valve is a means of taking live oil samples from the engine to provide a sample for analysis. The valve is located on the inlet side of the oil filters to capture a sample before being filtered.

The sample to be used for analysis must be representative of the oil in the engine.

It is also important to conduct oil analysis on new (unused) oil to establish a baseline. New (unused) oil analysis samples should be taken twice a year or each time the oil type is changed at a minimum. Samples should be taken from the bulk supply tanks to determine the makeup of the oil and also to confirm that no contaminants are being introduced by the storage system.

### 3.9.6 Circuit Breaker

A circuit breaker is used to prevent the generator from being overloaded.

A line circuit breaker is mounted in the generator output box. If the load exceeds the circuit breaker current rating, the line circuit breaker will open, preventing the generator from being overloaded. If the circuit breaker trips, locate the source of the overload and correct/eliminate the fault. Manually reset the breaker. Clear any fault messages and when safe to do so, reconnect the load to the generator.

### 3.9.7 Coolant Heater

<b>NOTICE</b>
<p><b>Operating the heater or heaters when the coolant system has been drained, or there is a suspicion that the coolant is frozen, can result in equipment damage.</b></p> <p><b>Always make sure the coolant is not frozen and the radiator is filled to the recommended level before energizing the heater, or heaters.</b></p>

A coolant heater keeps the engine coolant warm when the engine is shut down. It heats and circulates the coolant within the engine. This reduces start-up time and lessens engine wear caused by cold starts. It is electrically operated and thermostatically controlled.

### 3.9.7.1 Coolant Heater Components

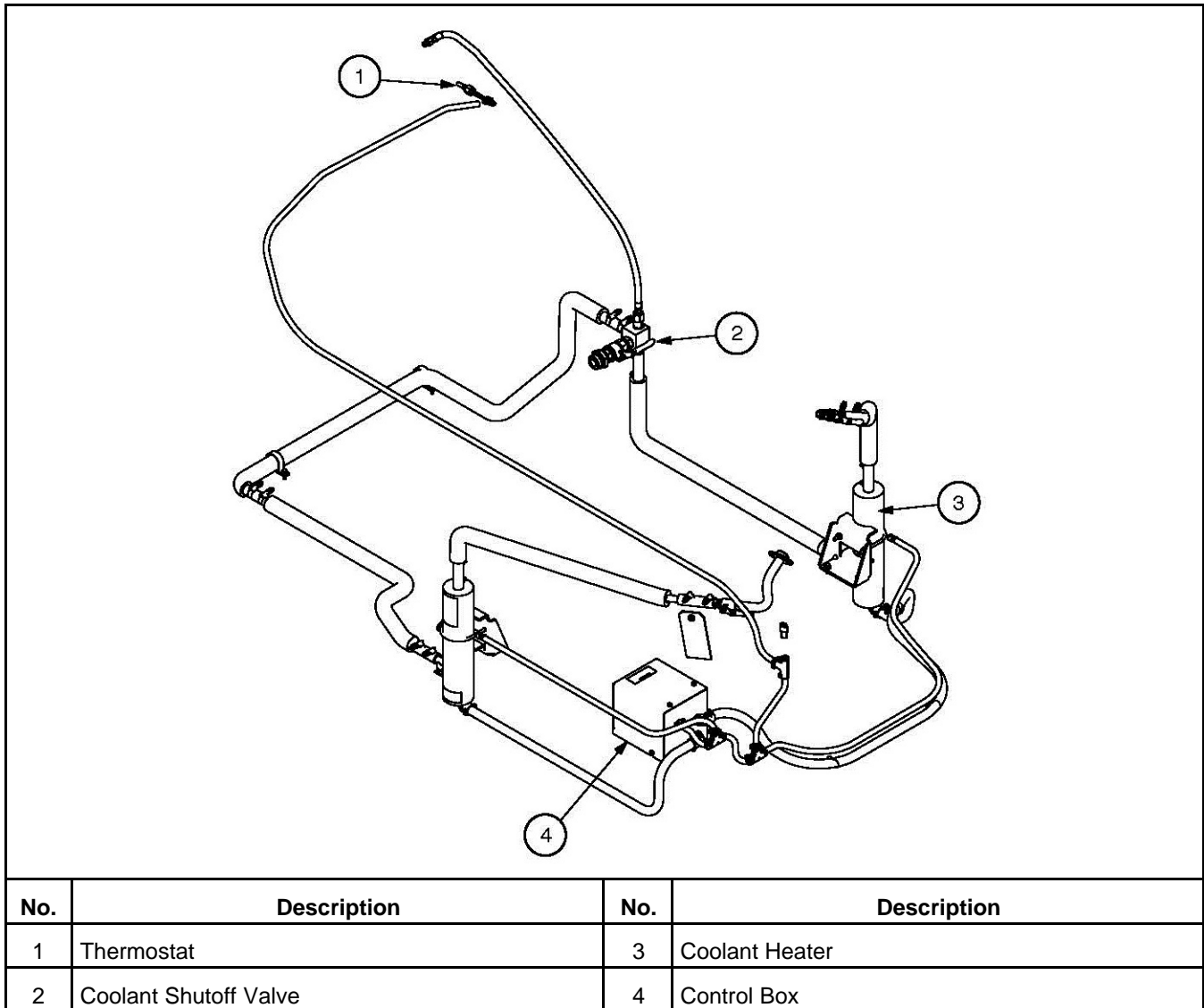

FIGURE 10. COOLANT HEATER COMPONENTS

### 3.9.8 Fuel Filters

The types of fuel filters that are available are:

- Single Fuel Filter - Standard filter for standby applications
- Duplex Fuel Filter - Optional filter for standby or prime applications
- Dual Fuel Filter - Optional filter for standby applications
- Triple Fuel Filter - Standard filter for prime applications
- Triplex Fuel Filter - Optional filter for standby or prime applications

The fuel filter assembly provides an all-in-one fuel filtration, fuel/water separator, and fuel warmer system.

The filter cover allows you to view the fuel level. When new, the fuel level in the filter is low. As it is used, the fuel level rises to show how much filter life remains.

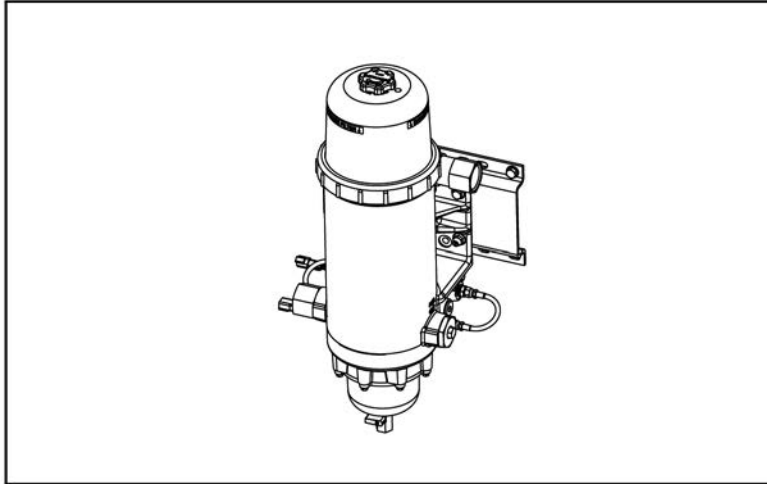

**FIGURE 11. SINGLE TALL FUEL FILTER**

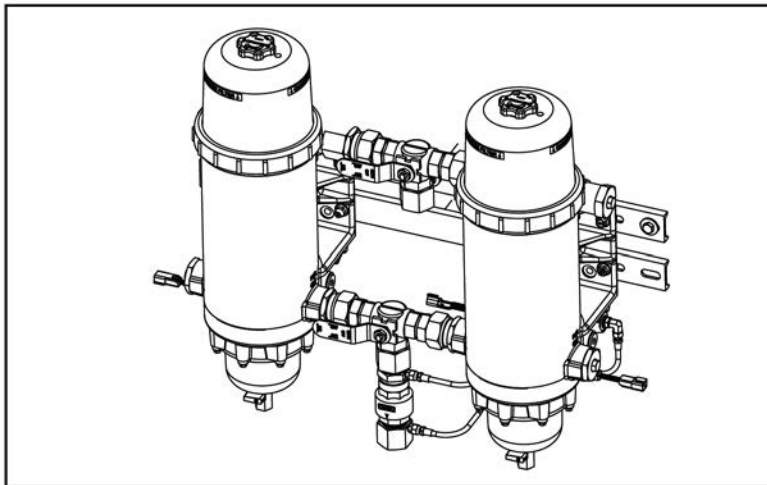

**FIGURE 12. DUPLEX FUEL FILTER**

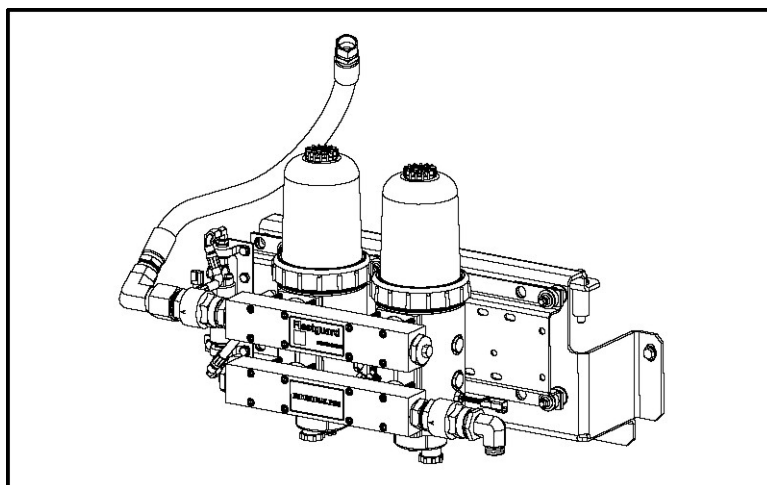

**FIGURE 13. DUAL FUEL FILTER**

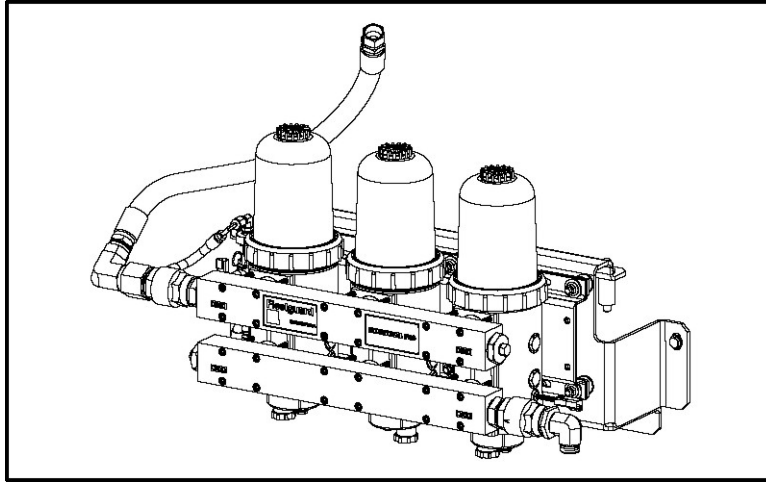

FIGURE 14. TRIPLE FUEL FILTER

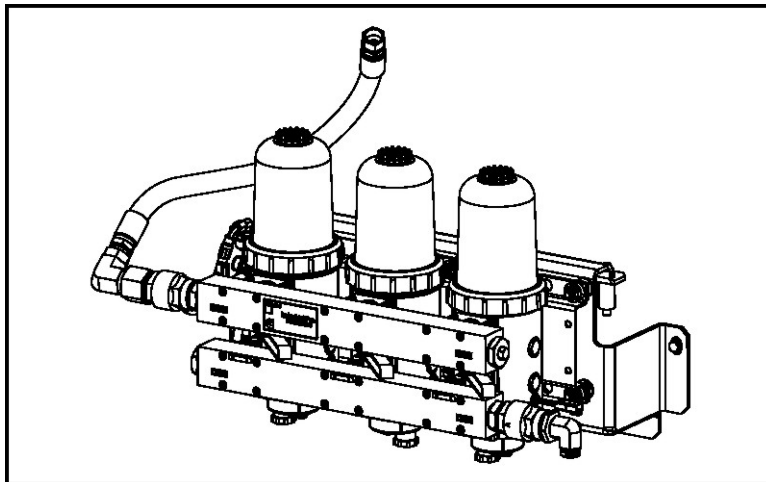

FIGURE 15. TRIPLEX FUEL FILTER

### 3.9.9 Oil Sampling Valve Introduction

The oil sampling valve is a means of taking live oil samples from the engine to provide a sample for analysis. The valve is located on the inlet side of the oil filters to capture a sample before being filtered.

The sample to be used for analysis must be representative of the oil in the engine.

It is also important to conduct oil analysis on new (unused) oil to establish a baseline. New (unused) oil analysis samples should be taken twice a year or each time the oil type is changed at a minimum. Samples should be taken from the bulk supply tanks to determine the makeup of the oil and also to confirm that no contaminants are being introduced by the storage system.

# 4 Control System - PowerCommand 3.3

---

## 4.1 Control System Description

The control system is used to start and stop the generator set from the display screen in either Manual or Auto mode. It is suitable for standalone or paralleling generator sets in both standby and prime-power applications, providing full generator set monitoring capability and protection. It monitors the engine for temperature, oil pressure and speed, and provides voltage and current metering. In the event of a fault the unit indicates the fault type and automatically shuts down the generator set on critical faults.

All indicators, control buttons and the display screen are on the face of the operator panel as illustrated in the following figure.

There are two fault level signals generated by the control system as follows:

- **Warning:** signals an imminent or non-critical fault for the engine. The control provides an indication only for this condition.
- **Shutdown:** signals a potentially critical fault for the engine. The control immediately takes the engine off-load and automatically shuts it down.

The standard control system operates on 12 VDC or 24 VDC battery power. The auxiliary equipment operates on LV AC power. The history data is stored in non-volatile memory and is not deleted if battery power is lost.

### 4.1.1 Control System Panel

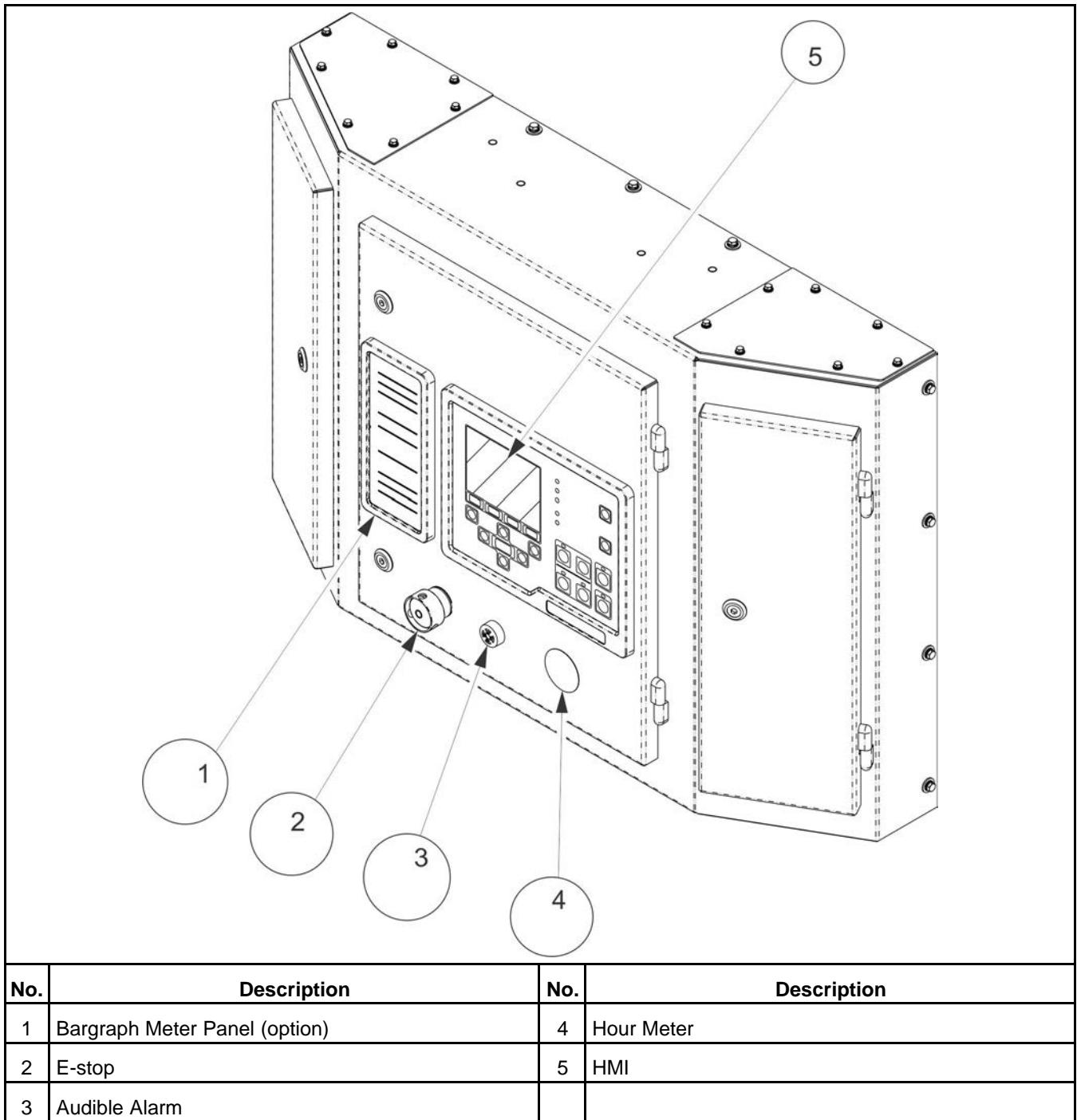

FIGURE 16. CONTROL SYSTEM PANEL

### 4.1.2 Operating Modes

The PowerCommand® 3.3 control is operated by the **Start/Stop/Manual/Auto** buttons on the Operator Panel. Refer to [Figure 18 on page 37](#).

**NOTICE**

If the Mode Change access feature is enabled, a password is required to use these buttons to change the mode of operation. Contact your authorized distributor for options.

**4.1.2.1 Stop Button**

Press this button to put the generator set into the Off mode. This disables Auto and Manual modes. The green lamp above this button lights when the generator set is in the Off mode.

If the generator set is running, in either Manual or Auto mode, and the **Stop** button is pressed, the engine shuts down.

Refer to the Selecting Operating Modes section for more information on stopping in Auto or Manual mode.

**NOTICE**

*If possible, hot shutdown under load should be avoided to help prolong the reliability of the generator set.*

**4.1.2.2 Manual Button**

Press this button to put the generator set into the Manual mode. The **Start** button must then be pressed within ten seconds. Failure to do this results in the control mode defaulting, putting the generator set into the Off mode.

The green lamp above this button is lit when the generator set is in Manual mode.

**NOTICE**

If the Mode Change access password feature is enabled, the password must be entered before pressing the Start button. See the Passwords and Mode Change section.

**4.1.2.3 Start Button**

When the **Manual** button is pressed, this **Start** button must be pressed within ten seconds to start the generator set. The generator set starts up normally but without the Time Delay to Start.

In other modes, this button has no effect.

**NOTICE**

*If the Start button is not pressed within the ten seconds of pressing the Manual button, the generator set mode changes to the Off mode automatically.*

#### 4.1.2.4 Auto Button



Press this button to put the generator set into the Auto mode. In this mode, the generator set is controlled by a remote switch or device (e.g. transfer switch).

The green lamp above this button lights when the generator set is in Auto mode.

#### 4.1.2.5 Battle Short Mode

##### **WARNING**

###### ***Automated Machinery***

***Battle Short mode overrides some parameters of generator set control. Unmonitored generator sets can cause a fire or electrical hazard, resulting in severe personal injury or death.***

***Make sure that the operation of the set is supervised during Battle Short operation.***

Battle Short mode is not a distinct mode of operation. The PowerCommand® control is still in the Off, Manual, or Auto mode while Battle Short mode is active. The PowerCommand® control still follows the appropriate sequence of operation to start and stop the generator set. Battle Short mode is a generator set mode of operation that prevents the generator set from being shut down by all but a few, select, critical shutdown faults.

The purpose of Battle Short mode is to satisfy local code requirements, where necessary. To use this feature, the necessary software must be installed at the factory when the PowerCommand® control is purchased. Only authorized service personnel can enable this feature. When shipped from the factory, this feature is disabled.

##### **NOTICE**

**The Battle Short feature must be enabled or disabled using the InPower service tool.**

This feature must only be used during supervised, temporary operation of the generator set. The faults that are overridden when in Battle Short mode can affect generator set performance, or cause permanent engine, alternator or connected equipment damage.

##### **NOTICE**

**If this mode of operation is selected, the protection of load devices will be disabled. Cummins will not be responsible for any claim resulting from the use of this mode.**

##### **NOTICE**

**All shutdown faults, including those overridden by Battle Short, must be acted upon immediately to ensure the safety and well-being of the operator and the generator set.**

Battle Short is turned on or off with an external switch connected to one of the two customer configured inputs or a soft switch on the operator panel.

When enabled, **Battle Short** switch input can be set using a Setup menu. To turn Battle Short mode on using the soft switch in the operator panel, **Battle Short** must be set to "Operator Panel" and enabled using the InPower service tool (default is Inactive).

When Battle Short mode is enabled, the Warning status indicator lights and code "1131 – Battle Short Active" is displayed.

When Battle Short mode is enabled and an overridden shutdown fault occurs, the shutdown lamp remains lit even though the set continues to run. "Fault code 1416 – Fail to Shutdown" is displayed. If the fault is acknowledge, the fault message is cleared from the display but remains in the Fault History file as long as Battle Short mode is enabled.

Battle Short is suspended and a shutdown occurs immediately if any of the following critical shutdown faults occur:

- Speed Signal Lost (Loss of Speed Sense) - Fault code 121
- Overspeed - Fault code 234
- Local Emergency Stop - Fault code 1433
- Remote Emergency Stop - Fault code 1434
- Excitation Fault (Loss of Voltage Sense) - Fault code 2335

Or

The Battle Short feature is disabled after an overridden shutdown fault occurred while in Battle Short mode. Fault code "1123 – Shutdown After Battle Short" is then displayed.

### 4.1.3 Power On and Sleep Modes

The operating modes of the control panel and operating software are Power On and Sleep.

#### Power On Mode

In this mode, power is continuously supplied to the control panel. The control's operating software and control panel lamps/graphical display remain active until the Sleep mode is activated.

#### Sleep Mode

Sleep mode is used to reduce battery power consumption when the control is not being used and it is in the Off or Auto mode. In this mode, the control's operating software is inactive and the lamps and graphical display on the control panel are all off.

When all conditions are met (i.e. no unacknowledged faults and the control is in the Off/Auto mode), the sleep mode activates after five minutes of keypad inactivity. This length of time is configurable.

To activate the control and view the menu display without starting the generator set, press any control button.

#### **NOTICE**

***Sleep mode can be enabled/disabled. Contact your authorized distributor for options.***

## 4.1.4 Hour Meter

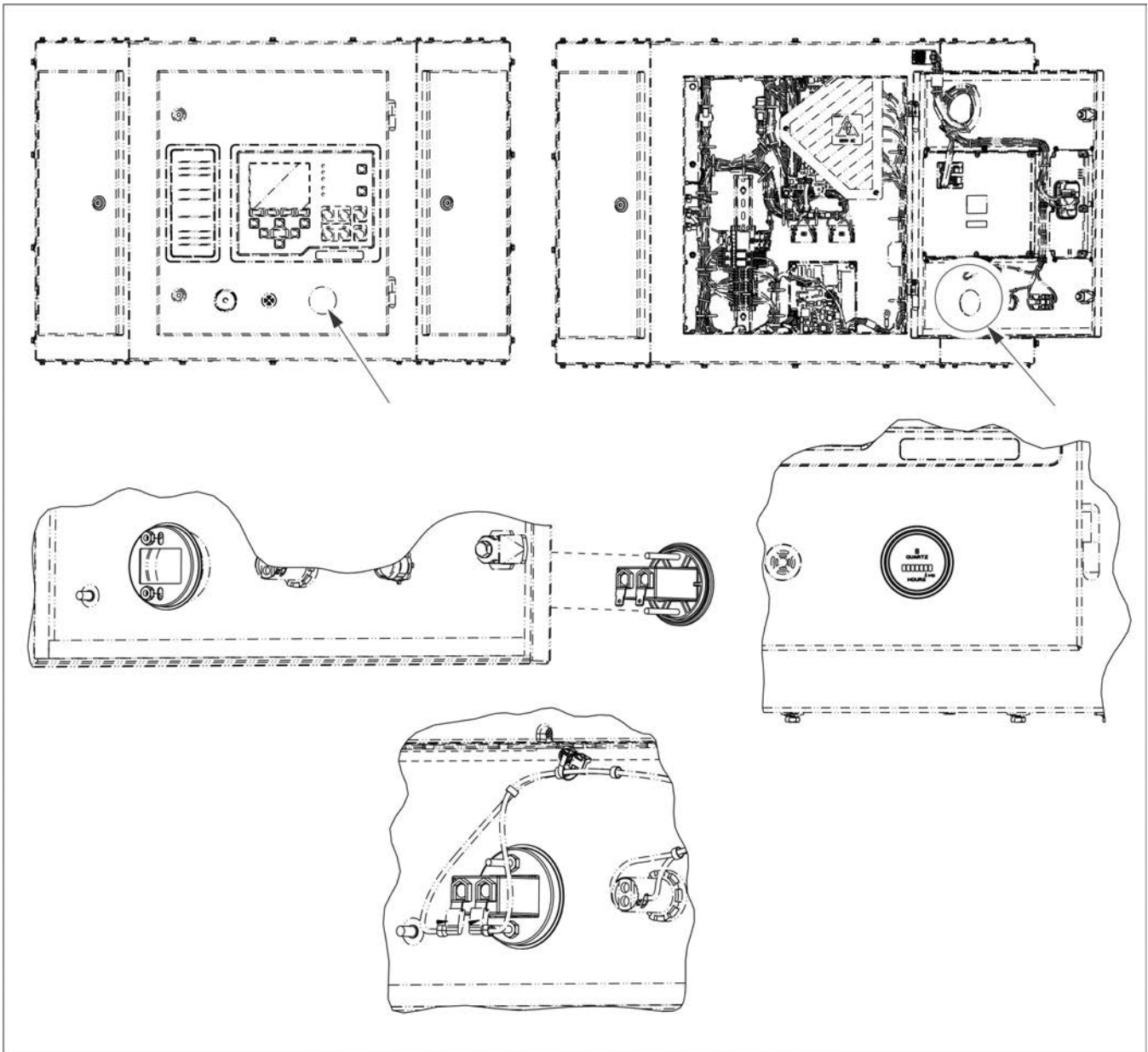
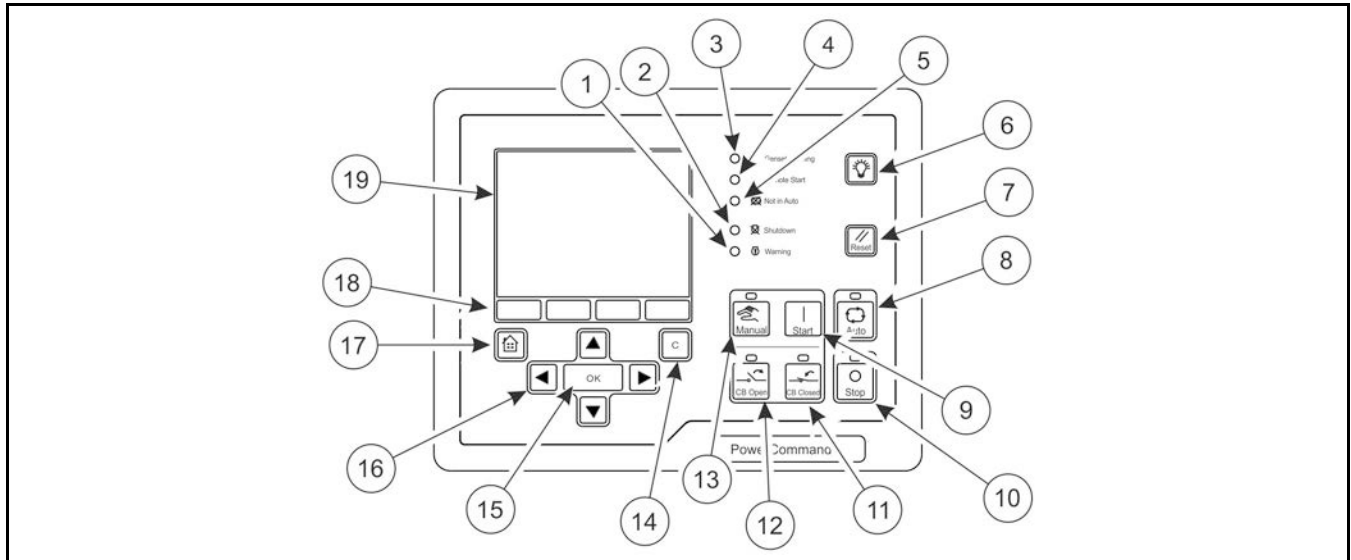

FIGURE 17. HOUR METER

## 4.2 Operator Panel

[Figure 18](#) shows the features of the front panel. It includes five lamp indicators; the graphical display with four menu select and seven menu navigation buttons; and six control mode buttons. This display panel enables the operator to look at the status, adjust the settings, and start and stop the generator set.



No.	Description	No.	Description
1	Indicator Lamp – Warning	11	Circuit Breaker – Closed Button
2	Indicator Lamp – Shutdown	12	Circuit Breaker – Open Button
3	Indicator Lamp – Genset Running	13	Manual Button
4	Indicator Lamp – Remote Start	14	Previous Menu Button (or Clear)
5	Indicator Lamp – Not in Auto	15	Item Select Button (OK)
6	Lamp Test Button	16	Menu Navigation Buttons (Up, Down, Left, Right)
7	Reset Button	17	Home Button
8	Auto Mode Button	18	Menu Select Buttons (Used with Graphical Display)
9	Start Button	19	Graphical Display
10	Stop Button		

FIGURE 18. OPERATOR PANEL

### 4.2.1 Selection Buttons

Four momentary buttons are used to navigate and change the selection in the graphical display:

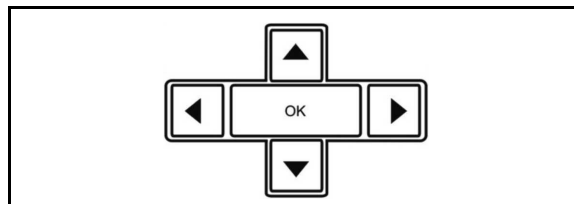

FIGURE 19. SELECTION BUTTONS

Press the **OK** button to select the item that is currently highlighted in the graphical display:

Item	Results of Pressing OK
Menu	Opens the sub-menu or screen
Parameter	Allows adjustment of the parameter (if possible) or prompts for a password
Adjusted Value	Saves the change
Action	The graphical display runs the action or prompts for a password

## 4.2.2 Default Settings

The operator panel can display SAE or Metric units of measurement and should be set during the initial setup of the generator set. Only trained and experienced personnel are allowed to change the default setting. Contact your authorized distributor.

## 4.2.3 Lamp Indicators

[Figure 18 on page 37](#) shows the front panel of the Operator Panel with the five lamp indicators.

### 4.2.3.1 Warning

This amber lamp is lit whenever the control detects a Warning condition. This lamp is automatically shut off when the Warning condition no longer exists.

### 4.2.3.2 Shutdown Status

This red lamp is lit when the control detects a Shutdown condition. The generator set cannot be started when this lamp is on. After the condition has been corrected, the lamp can be reset by first pressing the **Stop** button and then the **Reset** button.

### 4.2.3.3 Not in Auto

This red lamp is lit when the control is not in Auto.

### 4.2.3.4 Remote Start

This green lamp indicates the control is receiving a **Remote Run** signal. The **Remote Run** signal has no effect unless the generator set is in Auto.

### 4.2.3.5 Generator Set Running Lamp

The green lamp is lit when the generator set is running at, or near, rated speed and voltage. This is not lit while the generator set is warming up or cooling down.

## 4.2.4 Lamp (LED) Test Button

Press this button to test the lamps (LEDs). All of the lamps should turn on for five seconds.

Press and hold this for three seconds to turn on or off (to toggle) an external panel lamp.

## 4.2.5 Reset Button

Press this to reset any active faults.

If the condition(s) that caused an existing shutdown fault still exists, the generator set generates the fault again.

If the condition(s) that caused an existing warning fault still exists, the generator set generates the fault again, but the operator panel stops displaying it in the graphical display.

## 4.2.6 CB Open Button

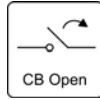

The **circuit breaker open** button is used for electrically operated circuit breakers in Manual mode only. When pressed, it enables the generator set circuit breaker to open and disconnect from the load.

## 4.2.7 CB Closed Button

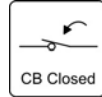

The **circuit breaker closed** button is used for electrically operated circuit breakers in Manual mode only. When pressed it enables the generator set circuit breaker to close when the set is up to speed and voltage and therefore, ready to accept the load.

### NOTICE

**This button has no effect unless the bus is dead, or the generator set is synchronized with the other source.**

## 4.2.8 Graphical Display and Buttons

[Figure 20 on page 40](#) shows the graphical display and the relevant menu selection buttons.

The graphical display is used to view menus of the menu-driven operating system. System messages (communication, event, and fault) are also shown on the display.

Four momentary soft-key buttons (item 5) are used to change menus, or pages within each screen. These selection buttons are “active” when any text or the up and down triangles (▲ and ▼ in Section 4) are displayed in the graphical display. Some sub-menus do not include any active buttons.

Use the graphical display to view event/fault information, status, screens, and parameters.

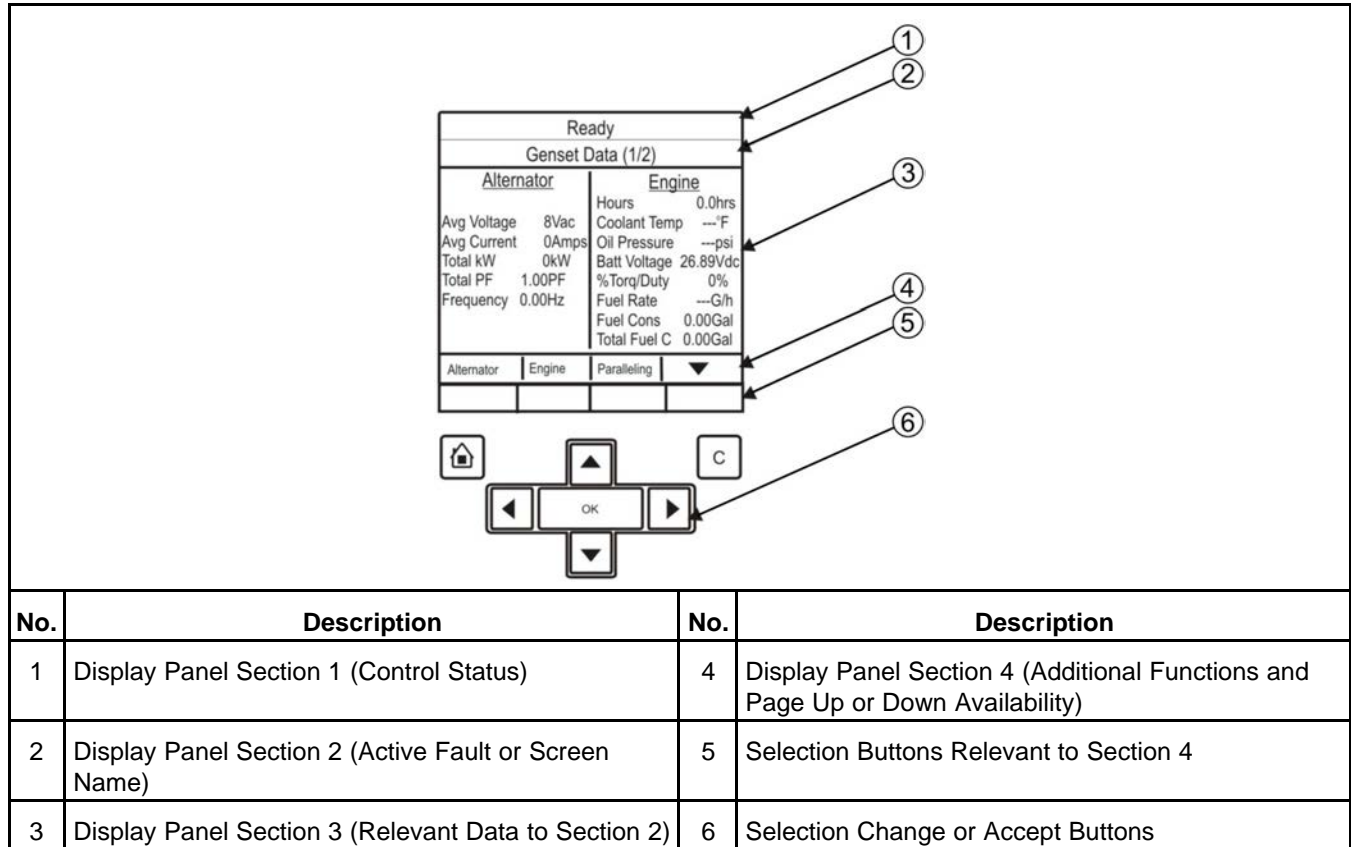

FIGURE 20. GRAPHICAL DISPLAY WITH TYPICAL SCREENSHOT

### 4.2.8.1 Section 1 - Control Status

Section 1 displays the status of the controller.

TABLE 4. CONTROL STATUS

Status	Description
Ready	This is the default state. The controller is ready to start the generator set, or it has started one of the start sequences but has not started the engine yet.
Starting	The controller is starting the engine in one of the start sequences, and the engine speed is greater than zero.
Idle Warmup	The controller is raising the engine speed to idle speed, or the engine is running at idle speed in one of the start sequences.
Rated Freq and Voltage	The controller is raising the engine speed to rated speed; the generator set is running at rated speed and voltage; or the controller has started one of the stop sequences but has not started reducing the engine speed yet.
Idle Cooldown	The controller is reducing the engine speed to idle speed, or the engine is running at idle speed in one of the stop sequences.
Stopping	The controller is stopping the engine, and the engine speed is still greater than zero.
Emergency Stop	There is an active shutdown fault.

Status	Description
Setup Mode	The controller is in Setup mode.
Wait to Powerdown	The controller is ready to enter Powerdown mode, but another device is sending a System Wakeup signal.
Off	The controller is in the process of entering power-down mode. The controller is performing some last-second checks.
Demo Mode	The controller is running a demonstration. Every screen is available in the demonstration, and any changes you make in the demonstration will have no effect on the controller. To end the demonstration, the operator panel must be turned off.

### 4.2.8.2 Section 2 - Active Fault or Screen Name

Section 2 displays the screen name and information about the last active shutdown fault. If there are no active shutdown faults, it displays the last active warning fault.

If there is an active fault, the operator panel displays the following information about it:

- Fault type
- Event/fault code
- Name of the controller that detected the fault (e.g., the engine ECM unit); this is blank if the controller detected the fault
- Fault name

If you press the **Reset** button, the operator panel stops displaying active warning faults, even if the condition(s) that caused the fault(s) has not been corrected. However, the Warning LED remains on.

The operator panel always displays any active shutdown faults, even if the **Reset** button is pressed.

**TABLE 5. ACTIVE FAULT TYPES**

Fault Type	Description
Warning	This is a warning fault. (See the Troubleshooting section.)
Derate	This is a derate fault. (See the Troubleshooting section.)
Shutdown	This is a shutdown fault that initiates a Shutdown Without Cooldown sequence. (See the Troubleshooting section.)
Shutdown with Cooldown	This is a shutdown fault that initiates a Shutdown With Cooldown sequence.

### 4.2.8.3 Section 3 - Interactive Screen or Menu

Section 3 shows information relevant to Section 2. You can view the operating values for the generator set, navigate through screen and adjust parameters (if permitted).

The default screen is the Genset Data screen.

The following table explains how the operator panel displays when the value of a specific parameter is missing, unexpected, or outside the range allowed for the parameter.

**TABLE 6. PARAMETER VALUES THAT ARE MISSING, UNEXPECTED, OR OUTSIDE THE RANGE ALLOWED**

Operator Panel	Description
NWF	Network Failure - There is a PCCNet network failure or a CAN (ECM) failure
OORL	Out Of Range Low - The value is less that the lowest allowed value for this parameter
OORH	Out Of Range High - This value is greater than the highest allowed value for this parameter
-- -- --	This value is not applicable

#### 4.2.8.4 Section 4 - Additional Functions Indicators

Section 4 indicates if additional information or further sub-menus are available by up or down arrows (▲ and ▼). If that particular page or menu has no additional information, then no arrow will be visible at this time.

For example if the graphical display is not big enough to display the screen at one time an up and/or down arrow (▲ and ▼) will be visible. Press the appropriate selection button beneath the graphical display to look at the previous or next page of information in that screen.

#### 4.2.8.5 Menu Navigation Buttons

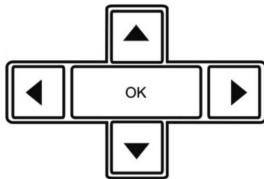

Four momentary buttons are used to navigate and change the selection in the graphical display.

Press the **OK** button to select the item that is currently highlighted in the graphical display:

- If the selected item is a menu item, this opens the sub-menu or screen.
- If the selected item is a parameter, this lets you adjust the parameter (if possible) or prompts you for a password.
- If the selected item is a value you have just adjusted, this saves the change.
- If the selected item is an action, the graphical display runs the action or prompts you for a password.

### 4.3 Operator Panel - Initial Operator Menu

[Figure 21 on page 44](#) shows the initial menu which is displayed over two pages. Use the soft-key buttons below the up and down arrows (▲ and ▼) to toggle between the two pages.

Use the soft-key buttons below Genset, Alternator, or Engine to short-cut to those menus.

Pressing the **Home** button  from any screen will return the display to the main menu screens.

#### 4.3.1 Initial Menu Data

This menu displays the information available through the menus.

**TABLE 7. INITIAL MENU DATA**

<b>Name</b>	<b>Description</b>
History/About	Use this screen to view historical information about your generator set.
Faults:	If there are no active Faults, these screens will not be available.
Active Shutdowns	Use this screen to view active Shutdown faults.
Active Warning	Use this screen to view active Warning faults.
History	Use this screen to view faults that have been cleared.
Paralleling Status	Use this screen to view the bus, circuit breakers, and paralleling states.
Genset Data	Use this screen to view the status of the generator set.
Alternator Data	Use this screen to view the status of the alternator.
Engine Data	Use this screen to view the status of the engine.
Advanced Status:	
Genset	Use this screen to view power, energy, phase difference, and other detailed generator set information.
Controller	Use this screen to view sequences of operation, configurable inputs and outputs, and other detailed controller information.
Engine	Use this screen to view pressures, voltages, temperatures, and other detailed engine information.
Help	Use this screen to obtain more information regarding the operator panel.
Setup Menus:	
Adjust	The use of these screens is restricted to authorized personnel only.
Genset Setup	
Paralleling Setup	
OEM Setup	
PCCnet Setup	
Modbus Setup	
Display Options	
Clock Setup	
Configurable IO	
Calibration	
Save/Reserve	

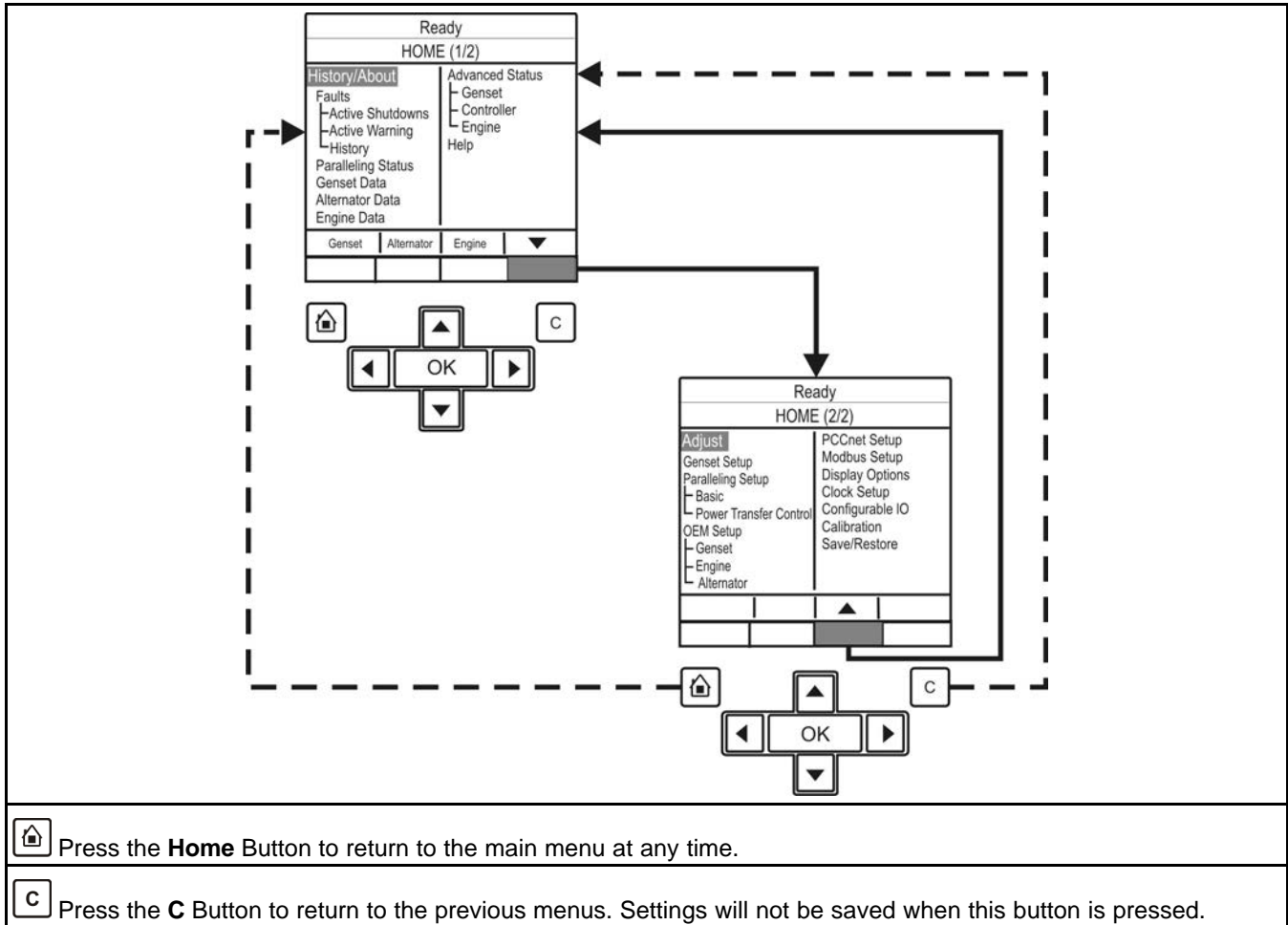
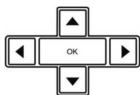

FIGURE 21. INITIAL OPERATOR MENU

## 4.4 Operator Panel - Generator Set Data Operator Menu

Figure 22 shows a block representation of a typical Genset Data menu. To navigate from the Home menu (HOME [1/2]), press the soft-key button below the function button indicating Genset. This will take you directly to the Genset menu.



The Genset Data menu is displayed on two pages. Use the two soft-key buttons below the up and down arrows (▲ and ▼) to toggle between the pages.

### 4.4.1 Generator Set Data

Use this menu to look at the status of the generator set.

**TABLE 8. GENERATOR SET DATA**

<b>PARAMETER</b>	<b>DESCRIPTION</b>
Alternator	
Genset LL Average Voltage	Generator Set Line to Line average voltage
Genset Average Current	Generator Set average current
Genset Total kW	Generator Set total kW
Genset Total Power Factor	Generator Set L1 power factor
Genset Frequency	Generator Set frequency
Engine	
Engine Running Time	Total engine run time
Coolant Temperature	Monitor point for the Coolant Temperature
Oil Pressure	Monitor point for the Oil Pressure Allowed values: 0~145 PSI.
Battery Voltage	Battery voltage value.
Percent Engine Torque/Duty Cycle	Monitor point for the percent engine torque output and the governor percent duty cycle output when used with the HM ECM Allowed values: -125~125%.
Fuel Rate	Monitor point for the Fuel Rate Allowed values: 0~845 liters/hr (223.2 gal/hr)
Fuel Consumption Since Reset	Fuel consumption since last reset.
Total Fuel Consumption	Total fuel consumption since start of engine.
Genset Application	
Genset Application kW rating	The Generator Set KW rating.
Genset Application kVA rating	The Generator Set KVA rating.
Genset Application Nominal Current	The value of the Generator Set application nominal current.
Genset Standby	
Genset Standby kW rating	KW rating for the Generator Set in Standby configuration.
Genset Standby kVA rating	KVA rating for the Generator Set in Standby configuration.
Genset Standby Nominal Current	The value of the Generator Set standby nominal current.



**TABLE 9. ENGINE DATA (LBNG GENSET ENABLE IS SET TO DISABLE)**

Name	Description
Oil Pressure	Monitor point for the Oil Pressure Allowed values: 0~145 PSI.
Boost Pressure	Monitor point for the Boost Absolute Pressure Allowed values: 0~148 PSI.
Coolant Pressure	Monitor point for the Coolant Pressure Allowed values: 0~145 PSI.
Fuel Supply Pressure	Monitor point for the Fuel Supply Pressure Allowed values: 0~145 PSI.
Fuel Outlet Pressure	Monitor point for the Fuel Outlet Pressure Allowed values: 0~36404 PSI.
Crankcase Pressure	Monitor point for the Crankcase Pressure Allowed values: -35.67~38 PSI.
Barometric Absolute Pressure	Monitor point for the Barometric Absolute Pressure Allowed values: 0~37 PSI.
Coolant Temperature	Monitor point for the Coolant Temperature
Oil Temperature	Monitor point for the Oil Temperature Allowed values: -40~410 °F.
Intake Manifold Temperature	Monitor point for the Intake Manifold Temperature Allowed values: -40~410 °F.
Fuel Temperature	Monitor point for the Fuel Temperature Allowed values: -40~410 °F.
Aftercooler Temperature	Monitor point for the Aftercooler Temperature Allowed values: -40~410 °F.
Battery Voltage	Battery voltage value
Average Engine Speed	Monitor point for the Average Engine Speed
Engine Running Time	Total engine run time
Glow Plug Command	Output of glow plug logic Allowed values: Driver Off, Driver On.
Oil Pressure Switch Status	Low or Not Low. Allowed values: Not Low, Low.

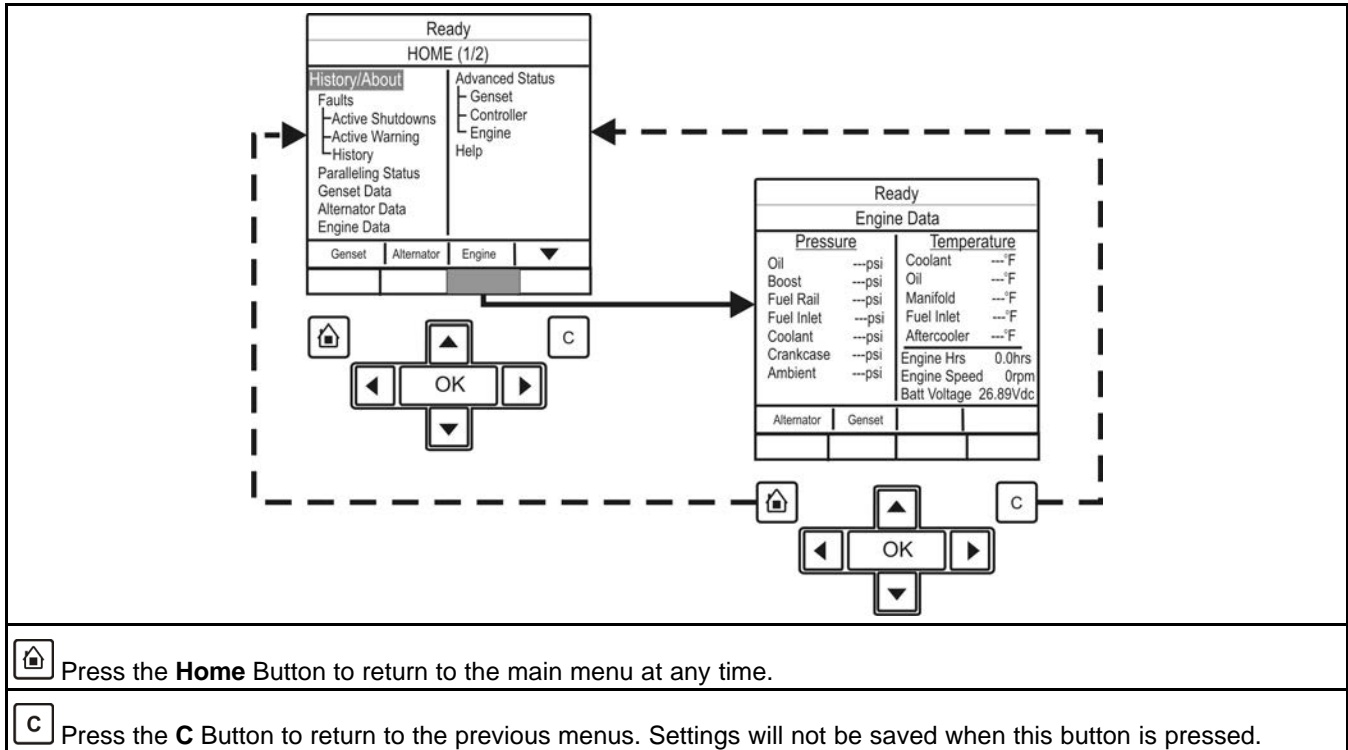

**FIGURE 23. ENGINE DATA MENU - TYPICAL DATA**

### 4.5.2 History/About Menu

[Figure 24 on page 50](#) shows a block representation of a typical History/About menu.

To navigate from the Home menu, toggle down until the History/About line of text is highlighted and press the **OK** button. This information is displayed over three pages. Use the two soft-key buttons below the up and down arrows (**▲** and **▼**) to toggle between the pages.

This screen displays the historical information about the generator set.

**TABLE 10. HISTORY/ABOUT**

Name	Description
Start Attempts (Starts)	Total number of start attempts Allowed values: 0~65535
Total Number of Runs (Runs)	Total number of generator set runs Allowed values: 0~65535
Engine Running Time (Engine Hours)	Total engine run time in hours
Controller On Time (Control Hours)	Controller ON time in hours, Upper limit is 136 years Allowed values: 0~4294967291 hours
Generator Set Total Net (Kw Hours)	Generator set total net kWh accumulation Allowed values: -2147483648~2147483643 kWh

Name	Description
Generator Set Model Number (Gen Mod #)	Number identifying the model of this generator set (Password level: 2)
Generator Set Serial Number (Gen Ser #)	Serial number identifying this generator set
Generator Set Nominal Voltage (Nominal Voltage)	Generator set nominal line-line voltage (Password level: 1) Allowed values: 1~45000 Vac (Default: 1 VAC)
Generator Set Delta/Wye Connection (Wye/Delta)	Delta or Wye for generator set connection (Password level: 1) Allowed values: Delta, Wye (Default: Wye)
Application Rating Select (Rating Select)	Selects generator set's standby/prime/base application rating (Password level: 1) Allowed values: Standby, Prime, Base (Default: Standby)
Controller Device Type (Contr Type)	Used by the PC Tool Allowed values: PCC3300, PCC3300 with Masterless Load Demand (MLD)
Calibration Part Number (Calib Part)	The unique calibration part number loaded into this control (Password level: 3)
Calibration Revision Date (Calib Date)	The revision date of the calibration part number loaded into this control (Password level: 3)
Firmware Version Number (Contr H/ ver)	Version of S/W loaded into this control, obtained from PCC Filename

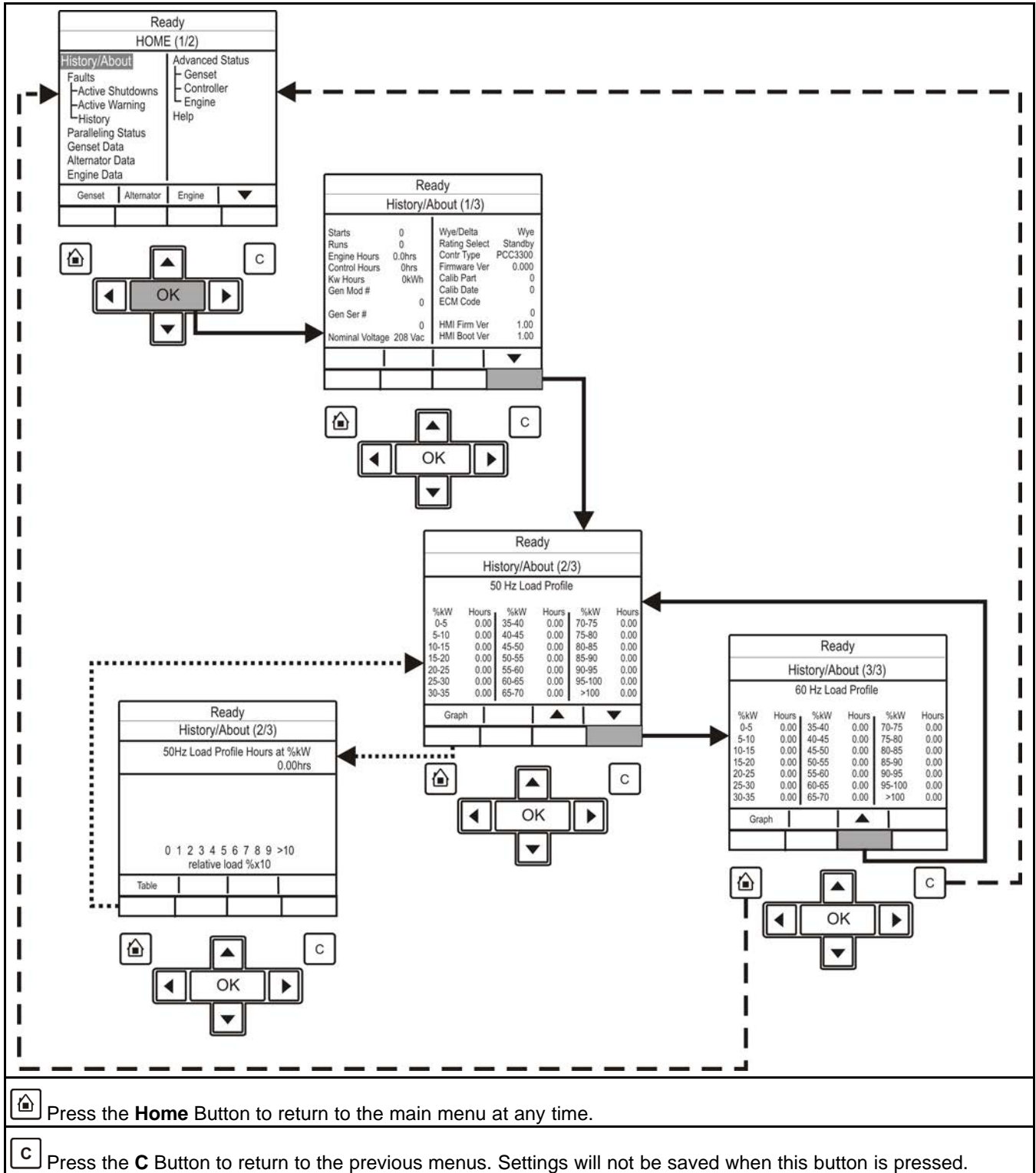

FIGURE 24. HISTORY/ABOUT MENU - TYPICAL DATA

## 4.6 Operator Panel - Alternator Data Operator Menu

[Figure 25 on page 53](#) shows a block representation of a typical Alternator Data menu. To navigate from the Home menu (HOME [1/2]), press the soft-key button below the function button indicating Alternator. This will take you directly to the Alternator menu.

The Alternator Data menu is displayed on one page.

### 4.6.1 Alternator Data

Use this menu to look at the status of the alternator. This menu displays line-to-line voltage, line-to-neutral voltage, current, and generator set power (in kVA). Some values are not available, dependent on the number of phases (one or three) and whether or not the application has current transformers.

**TABLE 11. ALTERNATOR DATA**

Parameter	Description
Genset L1L2 Voltage	Generator Set L1L2 voltage
Genset L1N Voltage	Generator Set L1N voltage
Genset L1 Current	Monitors the genset L1 current value
Genset L1 kW	Generator Set L1 kW
Genset L1 KVA	Generator Set L1 kVA
Genset L1 Power Factor	Generator Set L2 power factor Allowed values: -1.28~1.27 PF
Genset L2L3 Voltage	Generator Set L2L3 voltage
Genset L2N Voltage	Generator Set L2N voltage
Genset L2 Current	Generator Set L2 current
Genset L2 kW	Generator Set L2 kW Allowed values: -32768~32762 kW
Genset L2 KVA	Generator Set L2 kVA
Genset L2 Power Factor	Generator Set L2 power factor Allowed values: -1.28~1.27 PF
Genset L3L1 Voltage	Generator Set L3L1 voltage
Genset L3N Voltage	Generator Set L3N voltage
Genset L3 Current	Generator Set L3 current
Genset L3 kW	Generator Set L3 kW Allowed values: -32768~32762 kW
Genset L3 KVA	Generator Set L3 kVA Allowed values: 0~4294967.29 kVA
Genset L3 Power Factor	Generator Set L3 power factor Allowed values: -1.28~1.22 PF
Genset Total kW	Generator Set total kW
Genset Total KVA	Generator Set total kVA

Parameter	Description
Genset Total Power Factor	Generator Set L1 power factor
Genset Frequency	Generator Set frequency
AVR PWM Command	The AVR PWM software command. Linear relationship between counts and % duty cycle with 10000 counts=100% duty cycle
Genset Neutral Current	Generator Set neutral current  <b>NOTICE</b> <b>This is not displayed if the neutral current is not available.</b>
Ground Current	Ground current
Alternator Temperatures	
Non-Drive End Bearing Temperature (Aux101)	Monitor point for the Non-Drive End Bearing Temp input from the I/O Module. Allowed values: -65534~65535 °F
Drive End Bearing Temperature (Aux101)	Monitor point for the Drive End Bearing Temp input from the I/O Module. Allowed values: -32767~32762 °F
Alternator Temperature 1 (Aux101)	Monitor point for the Alternator Temp 1 input from the Aux 101 I/O Module. Allowed values: -32767~32762 °F
Alternator Temperature 2 (Aux101)	Monitor point for the Alternator Temp 2 input from the Aux 101 I/O Module. Allowed values: -32767~32762 °F
Alternator Temperature 3 (Aux101)	Monitor point for the Alternator Temp 3 input from the Aux 101 I/O Module. Allowed values: -32767~32762 °F

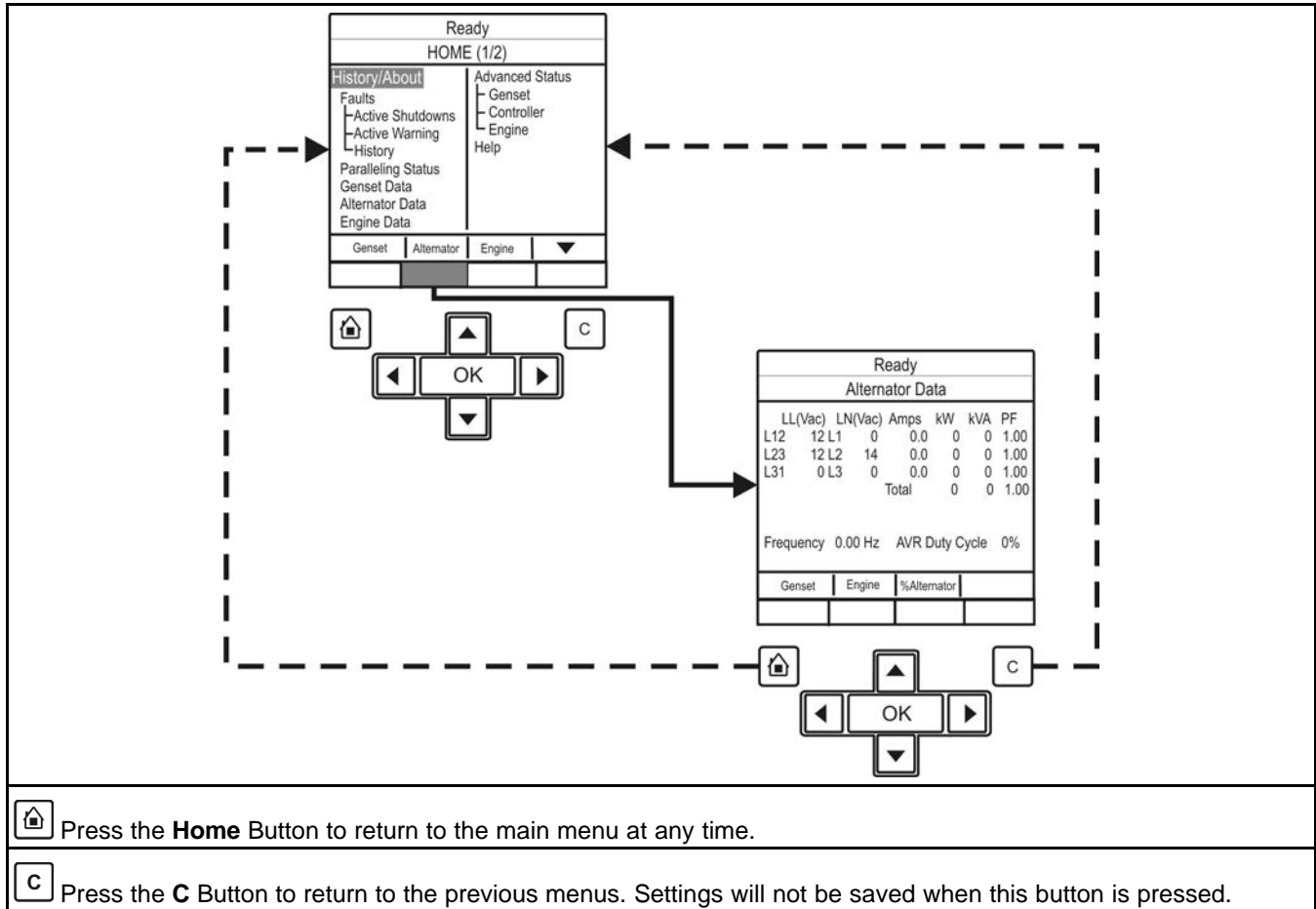

FIGURE 25. ALTERNATOR DATA MENU - TYPICAL DATA

## 4.7 Operator Panel - Faults and Warnings Menus

The Faults and Warning menu is divided into three main sub-sections; Shutdown Faults (Active Shutdowns); Warning Faults (Active Warnings); and Faults History (showing up to thirty-two faults that have been cleared).

### 4.7.1 Fault Menu

[Figure 26](#) shows a block representation of a typical Fault menu.

To navigate from the Home menu, select the Fault menu from the Home screen.

The fault menu home screen displays, which is divided into three main sub-sections: Active Faults (Active Shutdowns), Active Warnings, and Faults History. The Faults History screen shows up to thirty-two faults that have been cleared.

Use the two soft-key buttons below the up and down arrows (▲ and ▼) to toggle between the pages.

**TABLE 12. ACTIVE SHUTDOWN FAULTS**

Name	Description
Index	This is the index number of the fault
Fault	This is the fault code
SA	Source Address This is the controller that identified the fault, it is blank if the PCC identified the fault
Eng Hrs	This is how many hours the engine had run (not necessarily continuously) when the fault was generated
YY/MM/DD	This is the date the fault was generated
HH:MM:SS	This is the time the fault was generated
Response	This is the type of fault that was generated
	The name of the fault appears below the rest of the information

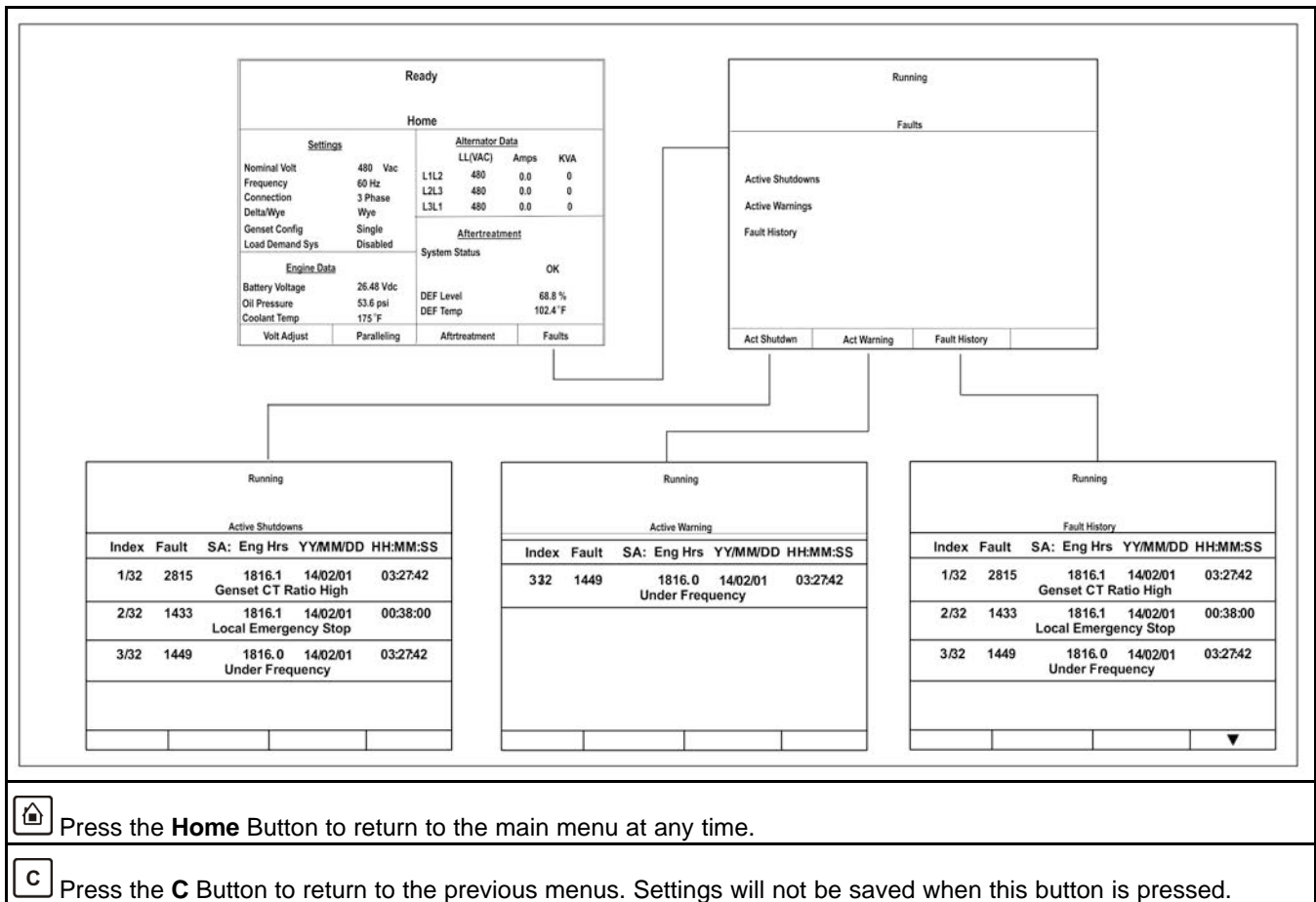

**FIGURE 26. FAULTS MENU**

## 4.7.2 Fault Messages

Ready Fault History				
Index	Fault SA:	Eng Hrs	DD/MM/YY	HH:MM:SS
427 1/2		0.0	15/06 00	18:50:41
CAN Data Link Degraded				
1689 2/2		0.0	00/00/00	00:00:00
Reset Real Time Clock				
Warnings   Shutdowns				

**FIGURE 27. FAULT MESSAGE DISPLAY SCREEN**

A Fault message is an indicator of a Warning or Shutdown condition. It includes the fault number, and a short description. It also includes where the fault occurred if the generator set control did not detect the fault and is simply reporting the fault. For a list of the fault codes, types, and message displayed, see [Chapter 7 on page 147](#).

Active and acknowledged faults may be viewed in the Faults menu.

## 4.7.3 Fault Acknowledgement

Shutdown faults must be acknowledged after the fault has been corrected. If in Auto or Manual mode, the control must be set to Stop mode (Off). Faults are cleared from the control panel display by pressing the **Reset** button.

Faults are re-announced if they are detected again after being acknowledged. See the Reset Button section.

### NOTICE

**Faults may also be acknowledged when in Auto mode and the Remote Start command is removed. Contact your authorized distributor for this option.**

## 4.7.4 Warning Fault Menu

[Figure 28](#) shows a block representation of a typical Warning Fault menu.

To navigate from the Home menu, toggle down until the Faults - Warning Fault line of text is highlighted and press the **OK** button. This will then display information regarding the current fault. Use the two soft-key buttons below the up and down arrows (▲ and ▼) to toggle between the pages.

This menu displays up to thirty-two faults. The same event/fault code may appear multiple times if detected by different sources.

**TABLE 13. ACTIVE WARNING FAULTS**

Name	Description
Index	This is the index number of the fault
Fault	This is the Fault code
SA	Source Address This is the controller that identified the fault, it is blank if the PCC identified the fault
Eng Hrs	This is how many hours the engine had run (not necessarily continuously) when the fault was generated
HH:MM:SS	This is the time the fault was generated.
Response	This is the type of fault that was generated.
	The name of the fault appears below the rest of the information



**TABLE 14. FAULTS HISTORY DATA OPERATOR MENU**

Name	Description
Index	This is the index number of the fault.
Fault	This is the Fault code.
SA	This is the controller that identified the fault. It is blank if the PowerCommand® 3.3 control identified the fault.
Engine Hrs	This is how many hours the engine had run (not necessarily continuously) when the fault was generated.
MM/DD/YY	This is the date the fault was generated.
HH/MM/SS	This is the time the fault was generated.
	The name of the fault appears below the rest of the information.

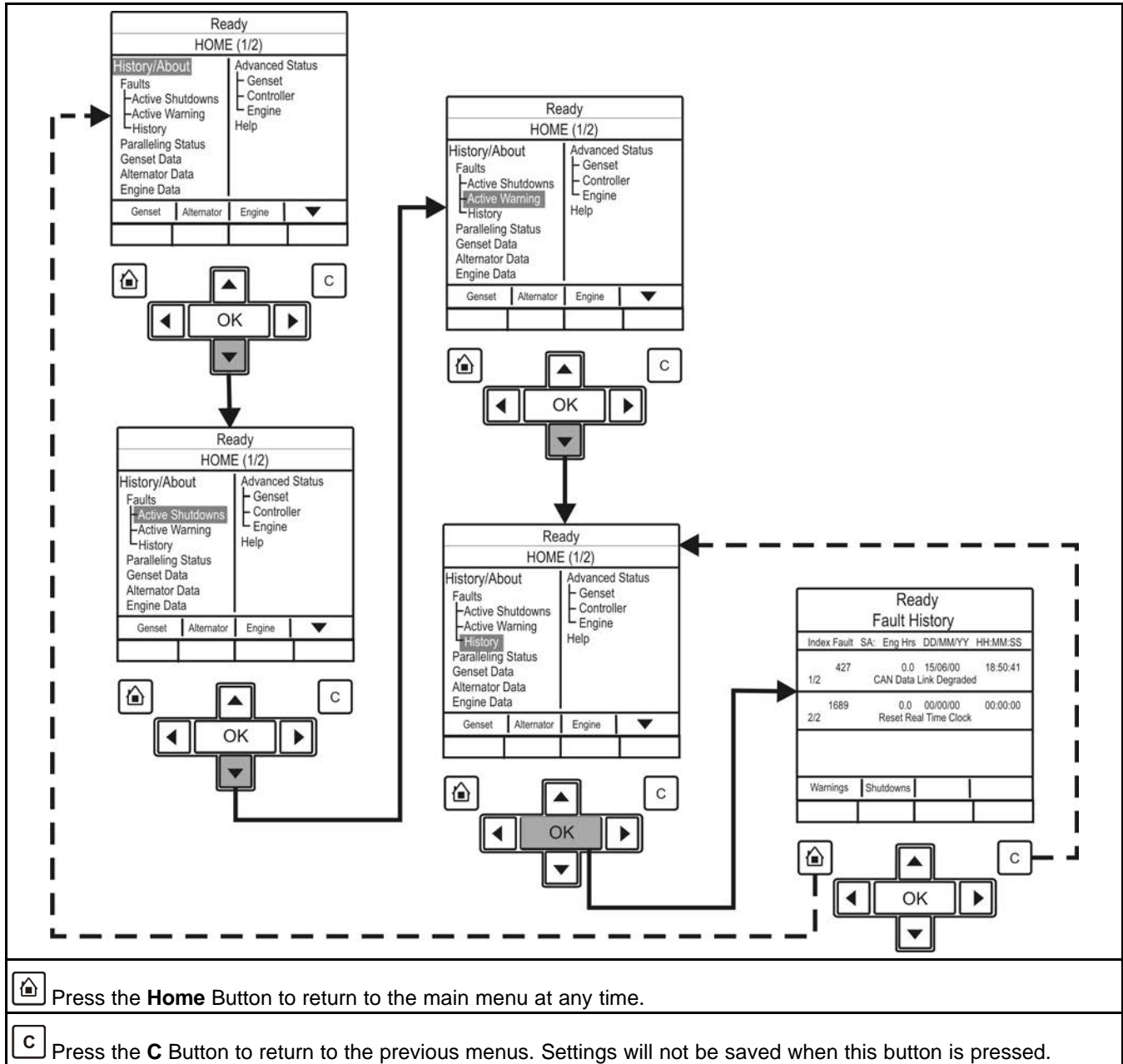

FIGURE 29. HISTORY FAULT MENU - TYPICAL DATA

## 4.8 Operator Panel - Adjust Menu

Figure 30 on page 61 shows a block representation of a typical Adjust menu. To navigate from the Home menu (HOME [1/2]), press the soft-key button below the down arrow in the display window. This will show the second page of the Home menu (HOME [2/2]). With the Adjust line of text highlighted, press the OK button to display the information.

The Adjust menu is displayed on one page.

**NOTICE**

Should any of these settings require amendment or change, please contact your authorized service center.

**NOTICE**

You cannot adjust Frequency Adjust or Voltage Adjust if Paralleling Speed Control Mode is set to Synchronize, Load Share, or Load Govern.

**TABLE 15. OPERATOR PANEL - ADJUST MENU**

<b>Name</b>	<b>Description</b>
<b>Voltage Adjust</b>	
Genset LL Average Voltage	Generator set Line-to-Line average voltage.
Voltage Adjust	A trim that allows the user to add/subtract an offset to the nominal voltage when calculating the voltage setpoint. Allowed values: -5~5%. Default value: 0%
Rated/Idle Sw	Allowed values: Rated, Idle. Default value: Rated.
Exer Switch	Allowed values: Inactive, Active. Default value: Inactive.
Man Warm Byp	Allowed values: Normal, Bypass Warmup.
<b>Keyswitch</b>	
Keyswitch Status	Allowed values: Inactive, Active.
<b>Frequency Adjust</b>	
Final Frequency Reference	The frequency scaled version of the final speed reference. Allowed values: 0~100 Hz.
Frequency Adjust	A method of adding in a frequency offset to the base frequency subject to high and low limit calibrations. Allowed values: -6~6 Hz. Default value: 0 Hz.
Avr Gain	A trim that allows the user to modify the overall gains of the AVR. Allowed values: 0.05~10. Default value: 1
Governor Gain	A trim that allows the user to modify the overall gain of the governor. Allowed values: 0.05~10. Default value: 1
Start Delay	Allowed values: 0~300 seconds. Default value: 0 seconds.
Stop Delay	Allowed values: 0~600 seconds. Default value: 0 seconds.

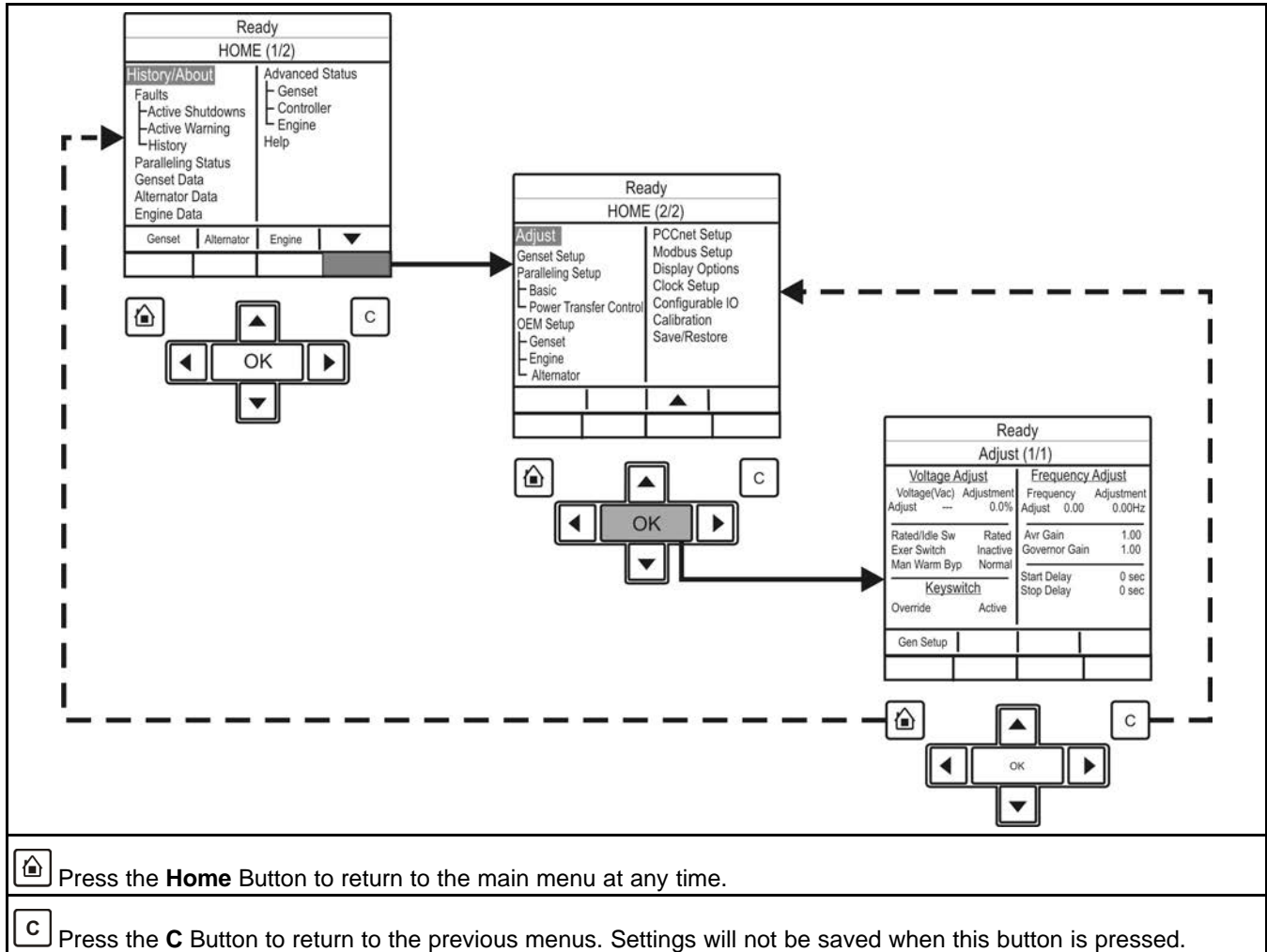

FIGURE 30. ADJUST MENU - TYPICAL DATA

## 4.9 Operator Panel - Genset Setup Data Operator Menu

Figure 31 on page 62 shows block representations of the Genset Setup Data menu.

Page down to the second page of the Home menu (using the two soft-key buttons below the up and down arrows [▲ and ▼]). See Section 4.3 on page 42.

In the HOME (2/2) menu, using the up and down arrows, toggle down again until the Genset Setup text is highlighted.

With the Genset Setup line of text highlighted, press the **OK** button. This will display the Setup Menu.

Use the two soft-key buttons below the up and down arrows [▲ and ▼] to page through the five pages of the Setup data.

**NOTICE**

**Should any of these settings require amendment or change, please contact your authorized service center.**

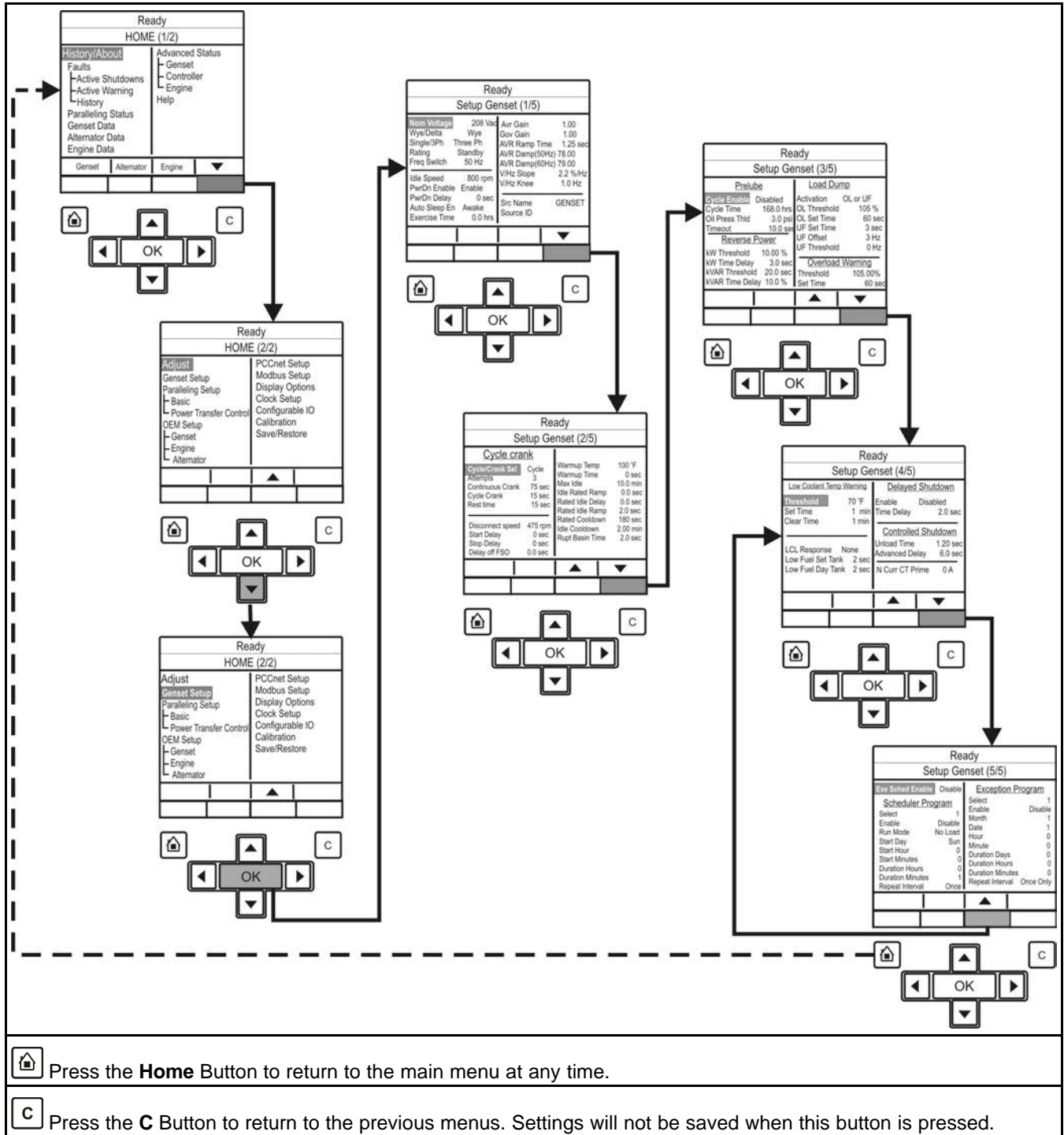

FIGURE 31. SETUP DATA MENU - TYPICAL DATA

## 4.10 Operator Panel - Paralleling Status Menu

Figure 32 on page 69 and Figure 33 on page 70 show block representations of a typical Paralleling Status menu. This screen varies according to the application type. See Section 5.8.3 on page 90.

In the HOME (1/2) menu, using the up and down arrows, toggle down until the Paralleling Status text is highlighted.

With the Paralleling Status line of text highlighted, press the **OK** button. This will then display the Paralleling Status Menu (if the generator set application type is not Standalone).

Use the two soft-key buttons below the up and down arrows [**▲** and **▼**] to page through the six pages of the Paralleling Status menu.

**TABLE 16. PARALLELING STATUS**

<b>Parameter</b>	<b>Description</b>
ES State	Internal paralleling status variable Allowed values: Standby, Dead Bus, Synchronize, Load Share, Load Govern
Genset LL Average Voltage	Generator set line-to-line average voltage
Genset Frequency	Generator set frequency
Genset Total kW	Generator set total kW
Genset Total kVAR	Generator set total kVAR
Genset Total Power Factor	Generator set L1 power factor
Genset CB Position Status	Indicates generator set breaker position Allowed values: Open, Closed, Not Available
Phase Match Error	Phase error signal for the synchronizer control algorithm
Load Demand Stop Command	Indicates status of the final load demand stop command to generator set start stop control function Allowed values: Don't Stop, Stop
Genset Bus LL Average Voltage	Generator set bus line-to-line average voltage
Genset Bus Frequency	Generator set bus line frequency
Genset Bus Total kW	Generator set bus total kW
Genset Bus Total kVAR	Generator set bus total kVAR
Genset Bus Total Power Factor	Generator set bus total power factor
Synchronizer Status	Indicates whether synchronizer is on or off Allowed values: Synchronizer Off, Synchronizer On
Bus Status	Indicates status of the bus Allowed values: Unavailable, Dead, Live
Permissive Close Allowed	Indicates when permissive sync check conditions have been met Allowed values: Not Allowed, Allowed
Phase Matched	Sync check phase match status Allowed values: Inactive, Active
Voltage Matched	Sync check voltage match status Allowed values: Inactive, Active

Parameter	Description
Frequency Matched	Sync check frequency match status Allowed values: Inactive, Active
Phase Match Error	Phase error signal for the synchronizer control algorithm
Frequency Match Error	Frequency match error value used by frequency match PI loop
Voltage Match Error	Voltage match error value used by voltage match PI loop
Load Govern kW Target	Indicates the final target set point for generator set kW output when paralleled to utility
Load Govern kVAR Target	Indicates the final target set point for generator set kVAR output when paralleled to utility
Power Factor Setpoint	Indicates analog input power factor set point derived from kVAR analog input
Paralleling Speed Control Mode	Indicates which speed control algorithm is in effect Allowed values: Isochronous, Droop, Synchronize, Load Share, Load Govern
Paralleling Voltage Control Mode	Indicates which voltage control algorithm is in effect Allowed values: Isochronous, Droop, Synchronize, Load Share, Load Govern
Genset CB Tripped Command	Generator set CB tripped command Allowed values: Inactive, Active (Default: Inactive)
Genset CB Inhibit Command	Generator set CB inhibit command Allowed values: Inactive, Active (Default: Inactive)
Load Share %kW Error	Indicates %kW error for load sharing control algorithm
Utility CB Tripped Command	Utility CB tripped command Allowed values: Inactive, Active (Default: Inactive)
Load Share %kVAR Error	Indicates %kVAR error for load sharing control algorithm
Utility CB Inhibit Command	Utility CB inhibit command Allowed values: Inactive, Active (Default: Inactive)
Utility Current Based Breaker Position	Indicates utility breaker position based on current
Genset Bus L1L2 Voltage	Generator set bus L1L2 voltage
Genset Bus L2L3 Voltage	Generator set bus L2L3 voltage
Genset Bus L3L1 Voltage	Generator set bus L3L1 voltage
Genset Bus L1N Voltage	Generator set bus L1N voltage
Genset Bus L2N Voltage	Generator set bus L2N voltage
Genset Bus L3N Voltage	Generator set bus L3N voltage
Genset Bus L1 Current	Generator set bus L1 current Allowed values: 0~65530 amps
Genset Bus L2 Current	Generator set bus L2 current Allowed values: 0~65530 amps
Genset Bus L3 Current	Generator set bus L3 current Allowed values: 0~65530 amps

Parameter	Description
Genset Bus L1 kW	Generator set bus L1 kW Allowed values: -32768~32762 kW
Genset Bus L2 kW	Generator set bus L2 kW Allowed values: -32768~32762 kW
Genset Bus L3 kW	Generator set bus L3 kW Allowed values: -32768~32762 kW
Genset Bus Total kW	Generator set bus total kW
Genset Bus L1 kVA	Generator set bus L1 kVA
Genset Bus L2 kVA	Generator set bus L2 kVA
Genset Bus L3 kVA	Generator set bus L3 kVA
Genset Bus Total kVA	Generator set bus total kVA
Genset Bus L1 Power Factor	Generator set bus L1 power factor Allowed values: -1.28~1.22 PF
Genset Bus L2 Power Factor	Generator set bus L2 power factor Allowed values: -1.28~1.22 PF
Genset Bus L3 Power Factor	Generator set bus L3 power factor Allowed values: -1.28~1.22 PF
Genset Bus Total Power Factor	Generator set bus total power factor
Genset Bus Frequency	Generator set bus line frequency
Genset Bus L1 Positive kWh	Generator set bus L1 positive kWh accumulation Allowed values: 0~4294967290 kWh (Default: 0 kWh)
Genset Bus L2 Positive kWh	Generator set bus L2 positive kWh accumulation Allowed values: 0~4294967290 kWh (Default: 0 kWh)
Genset Bus L3 Positive kWh	Generator set bus L3 positive kWh accumulation Allowed values: 0~4294967290 kWh (Default: 0 kWh)
Genset Bus Total Positive kWh	Generator set bus total positive kWh accumulation
Genset Bus L1 Negative kWh	Generator set bus L1 negative kWh accumulation Allowed values: 0~4294967290 kWh (Default: 0 kWh)
Genset Bus L2 Negative kWh	Generator set bus L2 negative kWh accumulation Allowed values: 0~4294967290 kWh (Default: 0 kWh)
Genset Bus L3 Negative kWh	Generator set bus L3 negative kWh accumulation Allowed values: 0~4294967290 kWh (Default: 0 kWh)
Genset Bus Total Negative kWh	Generator set bus total negative kWh accumulation
Genset Bus Total Net kWh	Generator set bus total net kWh accumulation
Genset Bus L1 Positive kVARh	Generator set bus L1 positive kVARh accumulation Allowed values: 0~4294967290 kVARh (Default: 0 kVARh)

Parameter	Description
Genset Bus L2 Positive kVARh	Generator set bus L2 positive kVARh accumulation Allowed values: 0~4294967290 kVARh (Default: 0 kVARh)
Genset Bus L3 Positive kVARh	Generator set bus L3 positive kVARh accumulation Allowed values: 0~4294967290 kVARh (Default: 0 kVARh)
Genset Bus Total Positive kVARh	Generator set bus total positive kVARh accumulation
Genset Bus L1 Negative kVARh	Generator set bus L1 negative kVARh accumulation Allowed values: 0~4294967290 kVARh (Default: 0 kVARh)
Genset Bus L2 Negative kVARh	Generator set bus L2 negative kVARh accumulation Allowed values: 0~4294967290 kVARh (Default: 0 kVARh)
Genset Bus L3 Negative kVARh	Generator set bus L3 negative kVARh accumulation Allowed values: 0~4294967290 kVARh (Default: 0 kVARh)
Genset Bus Total Negative kVARh	Generator set bus total negative kVARh accumulation
Genset Bus Total Net kVARh	Generator set bus total net kVARh accumulation
Genset Bus Reset All Energy Meters Timestamp - Hour	Time stamp of when energy meters were last reset Allowed values: 0~23 (Default: 0)
Genset Bus Reset All Energy Meters Timestamp - Minute	Time stamp of when energy meters were last reset Allowed values: 0~59 (Default: 0)
Genset Bus Reset All Energy Meters Timestamp - Second	Time stamp of when energy meters were last reset Allowed values: 0~59 (Default: 0)
Genset Bus Reset All Energy Meters Timestamp - Day	Time stamp of when energy meters were last reset Allowed values: 1~31 (Default: 1)
Genset Bus Reset All Energy Meters Timestamp - Month	Time stamp of when energy meters were last reset Allowed values: 1~12 (Default: 1)
Genset Bus Reset All Energy Meters Timestamp - Year	Time stamp of when energy meters were last reset Allowed values: 0~99 (Default: 0)
Genset Bus L1 kVAR	Generator set bus L1 kVAR Allowed values: -32678~32672 kVAR
Genset Bus L2 kVAR	Generator set bus L2 kVAR Allowed values: -32768~32762 kVAR
Genset Bus L3 kVAR	Generator set bus L3 kVAR Allowed values: -32768~32762 kVAR
Genset Bus L1L2 Phase Difference	Generator set bus L1L2 voltage phase angle
Genset Bus L2L3 Phase Difference	Generator set bus L2L3 voltage phase angle
Genset Bus L3L1 Phase Difference	Generator set bus L3L1 voltage phase angle

Parameter	Description
Genset Bus L1 kVAh	Generator set bus L1 kVAh accumulation Allowed values: 0~4294967290 kVAh (Default: 0 kVAh)
Genset Bus L2 kVAh	Generator set bus L2 kVAh accumulation Allowed values: 0~4294967290 kVAh (Default: 0 kVAh)
Genset Bus L3 kVAh	Generator set bus L3 kVAh accumulation Allowed values: 0~4294967295 kVAh (Default: 0 kVAh)
Genset Bus Total kVAh	Generator set bus total kVAh accumulation
Genset Bus Phase Rotation	Generator set bus phase rotation Allowed values: L1-L2-L3, L1-L3-L2, Not Available
System Network Termination Resistor Switch Status	Indicates the status of the on-board CAN termination resistor switch (S1)
Load Demand State	Indicates the status of load demand operation PCC3300 MLD controls only
Load Demand Online Capacity	Indicates the total amount of online kW bus capacity for load demand Only generator sets which are eligible for load demand count PCC3300 MLD controls only
Load Demand Genset Bus Total kW	Indicates the total load of system network connected generator sets PCC3300 MLD controls only
Load Demand Surplus Capacity	Indicates the amount of unused online kW bus capacity (spinning reserve) PCC3300 MLD controls only
Load Demand Total Spare Capacity Requested	Indicates the total kW value of all currently active spare capacity requests in the system PCC3300 MLD controls only
Load Demand Spare Capacity Available	Indicates when the current load and spare capacity requirements are satisfied PCC3300 MLD controls only
Load Demand Next Stop Threshold (kW)	The kW load at which the next generator set will be stopped PCC3300 MLD controls only
Load Demand Next Start Threshold (kW)	The kW load at which the next generator set will be started PCC3300 MLD controls only
Load Demand Next Gen to Start	Indicates Genset ID of the next generator set to start PCC3300 MLD controls only
Load Demand Next Gen to Stop	Indicates Genset ID of the next generator set to stop PCC3300 MLD controls only
Load Demand Initial Delay Timer	Indicates the time remaining before generator sets are allowed to stop after initial start or after resuming from halted load demand This timer is set by Load Demand Initial Delay PCC3300 MLD controls only
Load Demand Start Delay Timer	Indicates the time remaining before next generator set is allowed to start This timer is set by Load Demand Start Delay PCC3300 MLD controls only

Parameter	Description
Load Demand Stop Delay Timer	Indicates the time remaining before next generator set is allowed to stop This timer is set by Load Demand Stop Delay PCC3300 MLD controls only
Load Demand Inhibit Local	Indicates the status of the Load Demand Inhibit input When Active all the generator sets will start PCC3300 MLD controls only
Load Demand Genset Status Table	Indicates the load demand priorities and status of all load demand system network connected generator sets PCC3300 MLD controls only
Genset ID	Generator set identifier. All load demand generator sets must have a unique Genset ID PCC3300 MLD controls only
Load Demand Genset Run Hours	Run hour accumulator used for load demand run hour equalization This is writable Allowed Values: 0~999999.9 hours (Default: 0 hours) PCC3300 MLD controls only
System Network Datalink Status	Indicates communication status of the local generator set on system network (used for load demand) PCC3300 MLD controls only
Load Demand Spare Capacity Request Status	Indicates the status of the spare capacity request input When Active additional spare capacity (set by Load Demand Spare Capacity Request Value) is requested PCC3300 MLD controls only

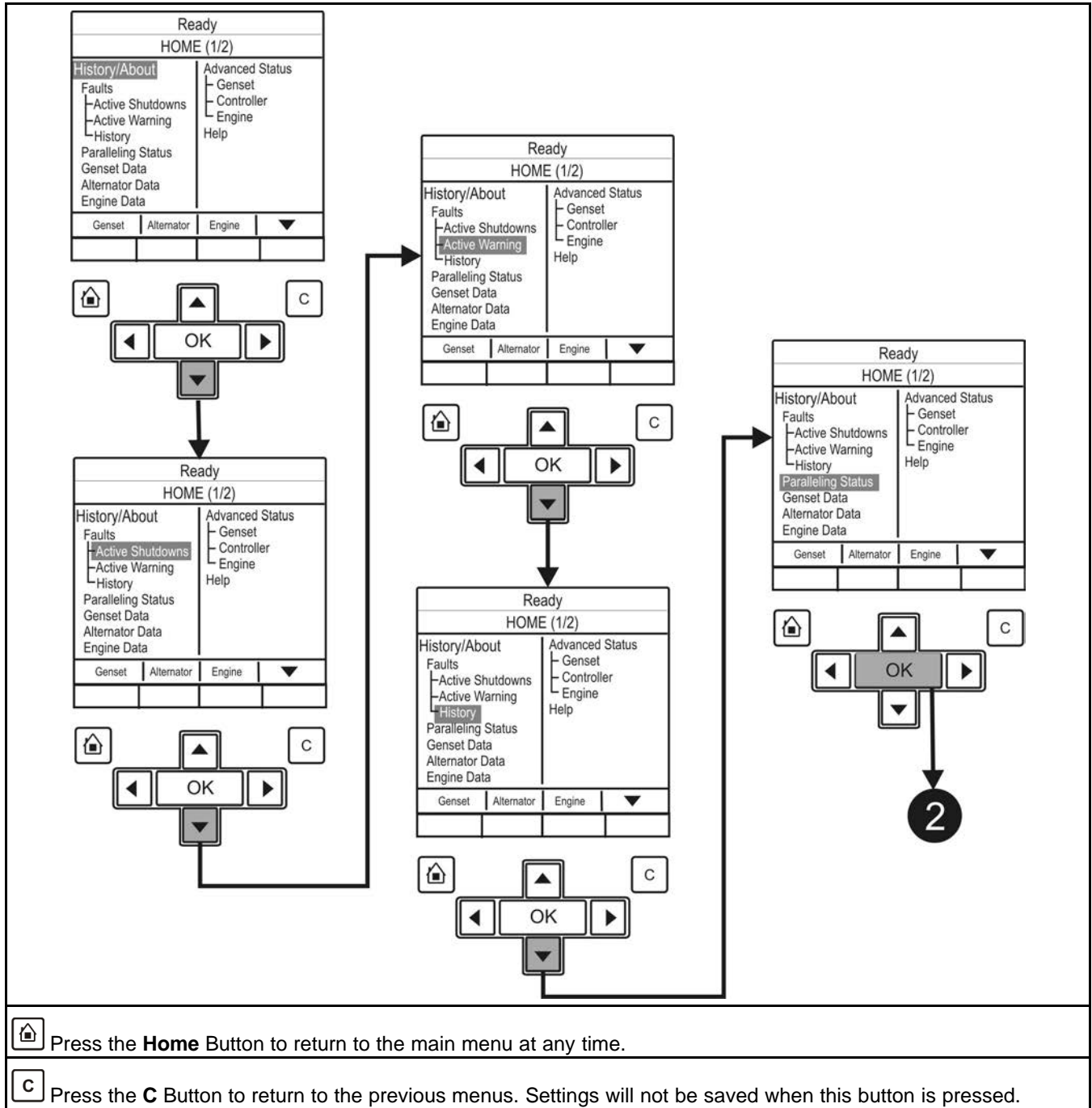

**FIGURE 32. PARALLELING STATUS DATA SHEET 1 - TYPICAL DATA**

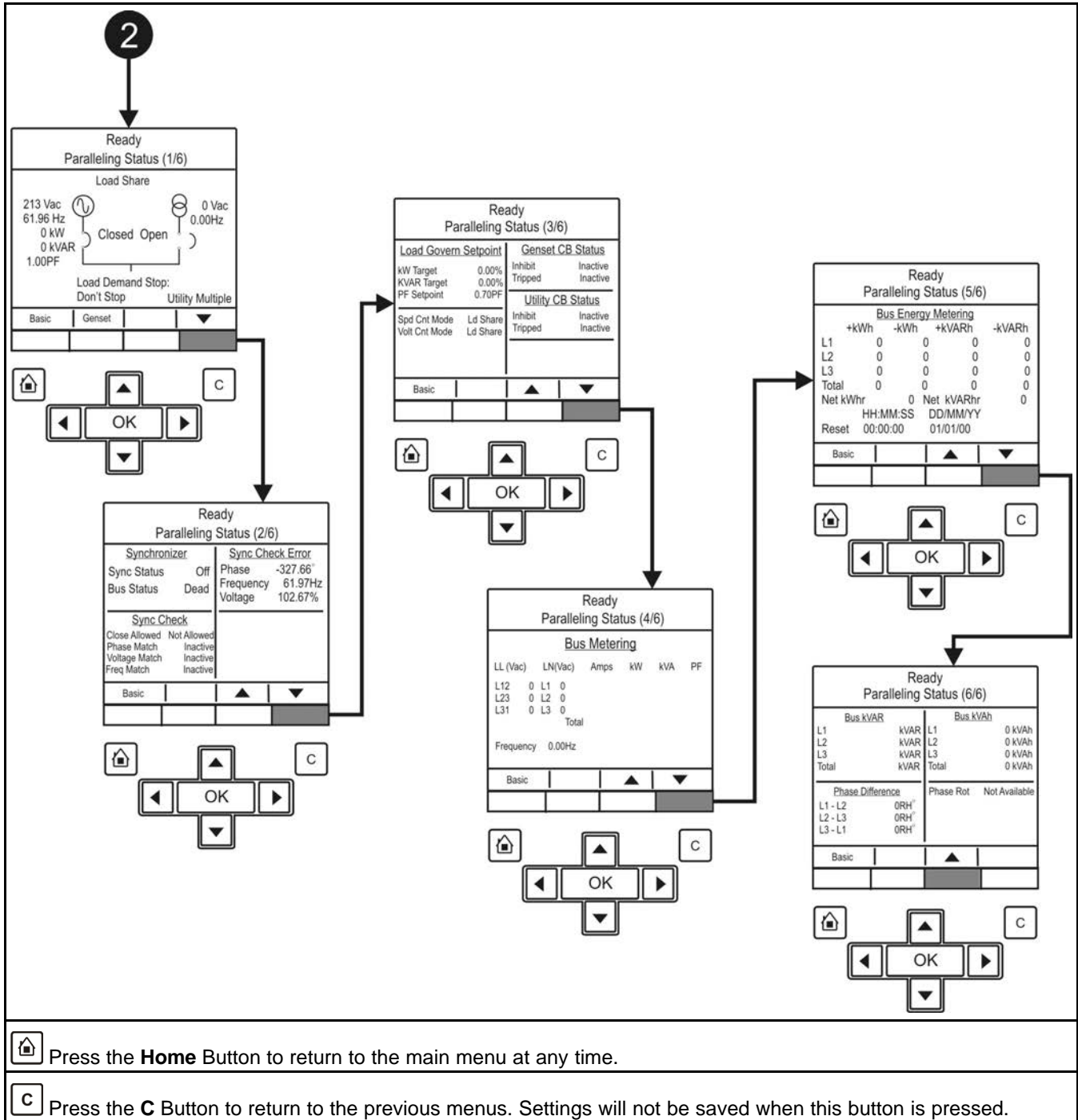

FIGURE 33. PARALLELING STATUS DATA SHEET 2 - TYPICAL DATA

## 4.11 Operator Panel - Paralleling/Basic Setup Menu

Figure 34 on page 72 and Figure 35 on page 73 show block representations of a typical Paralleling/Basic Setup menu.

---

To navigate from the HOME (1/2) menu, press the soft-key button below the down arrow in the display window. This will show the second page of the home menu (HOME 2/2). Using the up and down arrows, toggle down until the Paralleling/Basic Setup text is highlighted.

With the Paralleling/Basic Setup line of text highlighted, press the **OK** button. This will then display the Paralleling/Basic Setup Menu.

**NOTICE**

**It is also possible to short-cut to this menu by pressing the soft-key button below the function button indicating Basic within the Paralleling Status menu.**

Use the two soft-key buttons below the up and down arrows [▲ and ▼] to page through the six pages of the Paralleling/Basic Setup menu.

The adjustment of these submenus is intended for qualified service personnel and site personnel only and may require a USER password for this operation. If a password is required the USER password menu will appear when you try to modify the menu. (Refer to Password Menu in [Section 4.12.1.1 on page 74](#))

**NOTICE**

**Should any of these settings require amendment or change, please contact your authorized service center.**

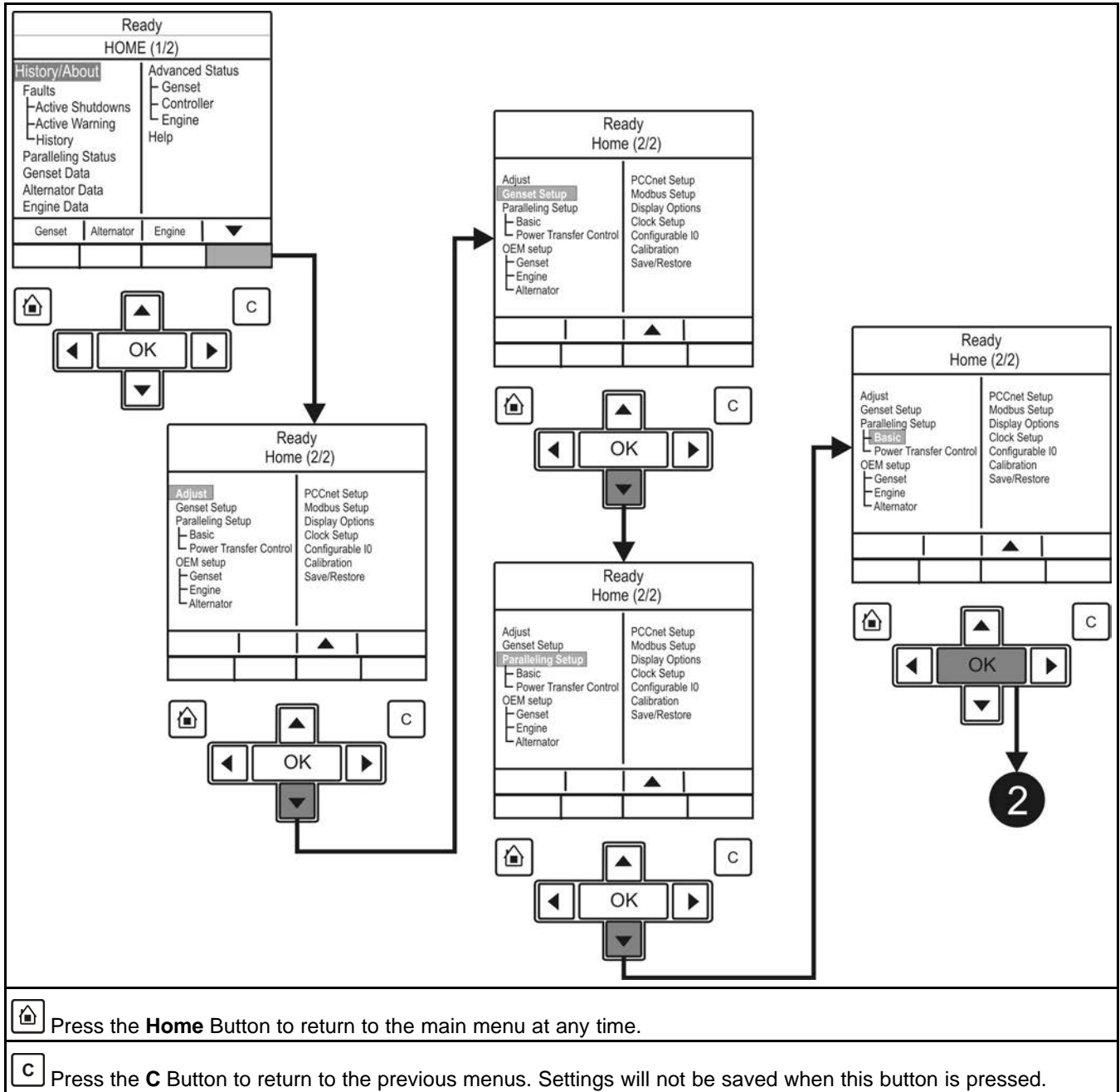

**FIGURE 34. PARALLELING/BASIC DATA (SHEET 1 OF 2) - TYPICAL DATA**

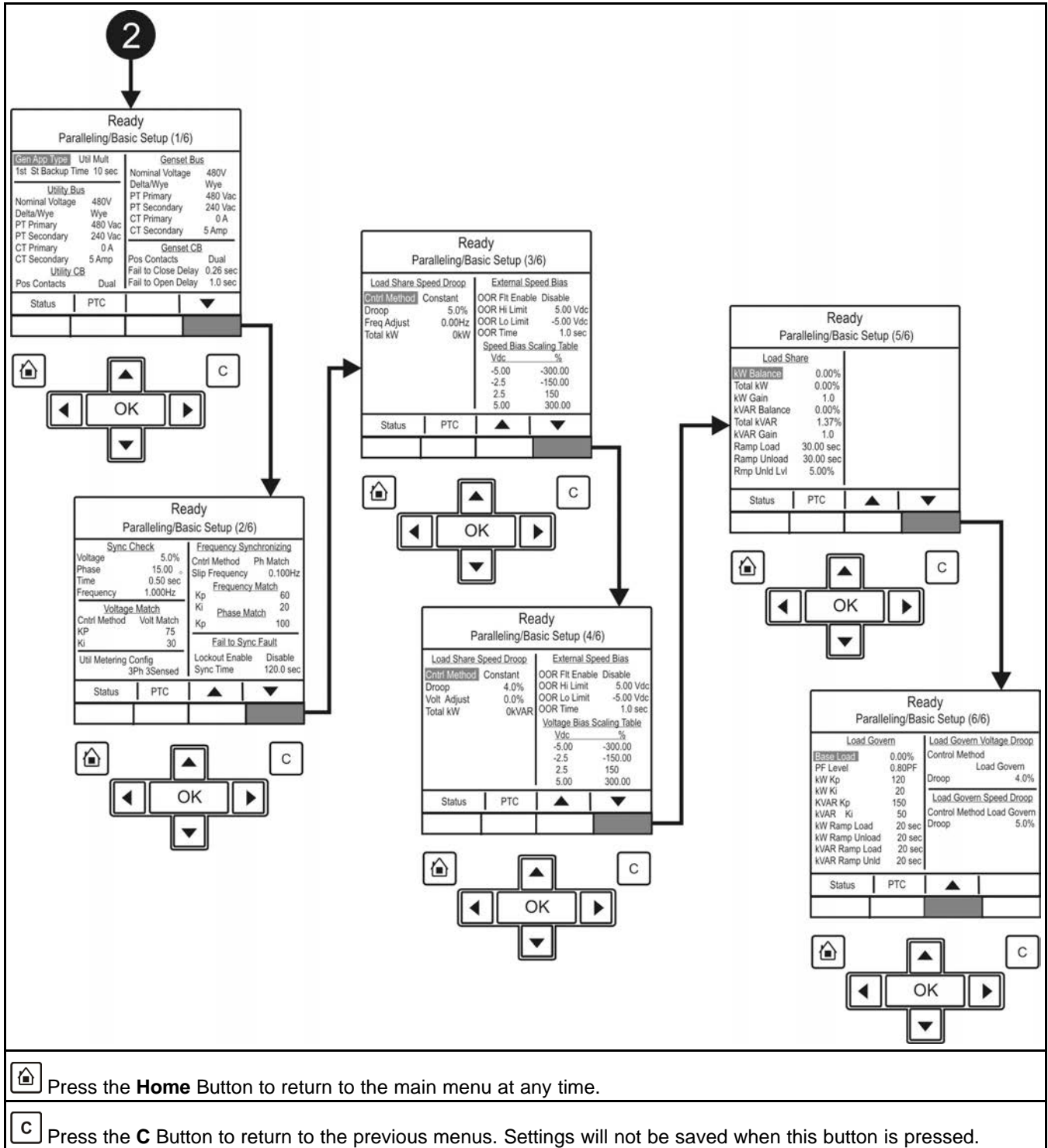

**FIGURE 35. PARALLELING/BASIC DATA (SHEET 2 OF 2) - TYPICAL DATA**

## 4.12 Selecting Operating Modes

### 4.12.1 Passwords and Mode Change Access

#### 4.12.1.1 Entering the Mode Change Access Code

The Mode Change submenus are intended for qualified service personnel and site personnel only, and by default will require an Access password. If a password is required, the Mode Change – Access Code menu will appear when you try to switch between Auto, Manual Run, or Stop modes.

To enter the mode access code:

1. With the first character highlighted, press the up and down arrow buttons until the required value is displayed.
2. Press the left arrow button to move to the next numeric character.
3. Repeat steps 1 and 2 until all characters of the Access Code are correct.
4. After you have completed entering the password, press the **OK** button.



FIGURE 36. MODE CHANGE ACCESS CODE DISPLAY SCREEN

#### NOTICE

**If an incorrect password is entered, the Operator menu that was displayed before Auto, Manual Run, or Stop mode was selected is re-displayed.**

#### 4.12.1.1.1 Passwords

It is possible for the operator to view every parameter in the graphical display; however, a password may be required before adjustment of a parameter is permitted. The generator set will prompt you if a password is required and inform you of the level of password required.

TABLE 17. PASSWORDS



Level	Description	Comment
0	No password	None required
1	Operator password	Restricted
2	Service password	Restricted
3	Engineering password	Restricted

## 4.12.2 Selecting Manual Run Mode

### NOTICE

When changing modes, the generator set may start or stop without warning. Make sure there is no danger to personnel or equipment should the generator set unexpectedly start or stop.



Press the **Manual** button  and then (within ten seconds) the **Start** button . This bypasses the "Time Delay to Start" function and activates the engine control system and the starting system.

If the engine does not start, the starter disengages after a specified period of time and the controller indicates a "Fail to Start" shutdown.

The generator set can be configured for 1–7 starting cycles with set times for crank and rest periods for all starting modes (manual/remote). The default setting is 3 start cycles, composed of 15 seconds of cranking and 30 seconds of rest.

### NOTICE

The InPower service tool or access to the setup menu is required to change the cycle number, and crank and rest times. Contact your authorized distributor for assistance.



To clear a Fail to Start shutdown, press the **Stop** button  and then press the **Reset** button .

Before attempting to restart, wait 2 minutes for the starter motor to cool and repeat the starting procedure. If the engine does not run after a second attempt, refer to the Troubleshooting section.

## 4.12.3 Selecting Auto Mode

### NOTICE

When changing modes, the generator set can start or stop without warning. Make sure there is no danger to personnel or equipment should the generator set start or stop.

### NOTICE

Make sure that it is safe to do so before proceeding to change the mode.



Press the **Auto** button.  This allows the generator set to be started from a remote switch or device (e.g. transfer switch).

In response to the **Remote Start**, the control lights the Remote Start indicator and initiates the starting sequence. This start incorporates a Time Delay to Start function.

### NOTICE

The InPower service tool or access to the setup menu is required to change the cycle number, and crank and rest times. Contact your authorized distributor for assistance.

**NOTICE**

**Should a remote start signal be received, the generator set starts automatically. Make sure there is no danger to personnel or equipment should the generator set start without warning.**

The starting/stopping sequence for a remote start is as follows:

1. A **remote start** signal is received at the customer connection on the generator set. This input signal is received from a transfer switch, a remote start switch, etc.
2. The Time Delay to Start (0–300 seconds) begins.
3. When the Time Delay to Start has expired, the engine starts. Once it has reached its rated speed and voltage, the generator set is available for use.
4. When the **remote start** signal is removed, a Time Delay to Stop (0–600 seconds) begins. This time delay is used to transfer the load (if connected to another power source) and let the engine cool down.
5. When the Time Delay to Stop has expired, the engine stops.

**NOTICE**

**If the emergency stop or control off button is pressed at any time during the starting/stopping sequence, the engine immediately stops, bypassing the cooldown sequence.**

## 4.12.4 Selecting Off Mode

**NOTICE**

**When changing modes, the generator set can stop without warning. Make sure there is no danger to personnel or equipment should the generator set stop.**



Press the **Stop** button  to put the generator set into the Off mode. This disables Auto and Manual modes.

If the generator set is running in either Manual or Auto mode, and the **Stop** button is pressed, the engine will shut down. This action may include a cool down run.

**NOTICE**

**Do not perform a hot shutdown under load; a hot shutdown may result in engine damage.**

# 5 Operation - PowerCommand 3.3

---

## 5.1 Safety

### WARNING

#### **Toxic Gases**

*Inhalation of exhaust gases can cause asphyxiation and death.*

*Use extreme care during installation to provide a tight exhaust system. Terminate exhaust pipes away from enclosed or sheltered areas, windows, doors, and vents. Do not use exhaust heat to warm a room, compartment, or storage area.*

### WARNING

#### **Hazardous Voltage**

*Contact with high voltages can cause severe electrical shock, burns, or death.*

*Do not open the generator set output box while the generator set is running. Read and observe all warnings and cautions in the generator set manuals.*

### CAUTION

#### **Hazardous Voltage**

*Contact with high voltages can cause severe electrical shock, burns, or death.*

*Make sure that only suitably trained and experienced service personnel perform electrical and/or mechanical service. Even with the power removed, improper handling of components can cause electrostatic discharge.*

Only trained and experienced personnel should carry out generator set operations. Before operating the system, the operator should become familiar with all health and safety procedures, warnings, cautions, precautions, and the other documentation supplied with the generator set. (See [Chapter 1 on page 1](#)). Observe all of the warnings and cautions at all times.

### NOTICE

**Before operating the generator set become familiar with the equipment and how it is operated (including all controls, manually operated valves, and alarm devices). Safe and efficient operation can only be achieved if the generator set is operated correctly.**

## 5.2 Introduction

This section describes the operation of the generator set. The text should be read in conjunction with the System Overview and the Control System Sections of this manual.

All indicators, control switches/buttons, and graphical display are located on the face of the Operator Panel as illustrated in [Figure 18 on page 37](#).

---

## 5.3 Maintenance

To ensure maximum performance and reliability from your generator set, it is essential that certain components are inspected periodically and, where necessary, maintenance procedures are carried out, as detailed in the Maintenance chapter.

## 5.4 Operating Recommendations

### 5.4.1 Running-in

Refer to the Maintenance chapter of this manual. Special "running-in" oils are not recommended for new or rebuilt Cummins engines. Use the same type of oil during "running-in" as is used in normal operation.

The engine should be run at varying loads during the first few hours of operation to allow the components to "bed in." Avoid long periods of light load or full load running particularly during the early life of the engine.

### 5.4.2 No Load Operation

Periods of no load operation should be held to no longer than 15 minutes. Long periods of no load operation can result in engine and (if fitted) diesel particulate filter damage.

If it is necessary to keep the engine running for long periods of time when no electric output is required, best engine performance will be obtained by connecting a load of at least 30% rated load, but not to exceed rated load. Such a load could consist of a heater element or load bank.

### 5.4.3 Exercise Period

Generator sets on continuous standby must be able to go from a cold start to being fully operational in a matter of seconds. This can impose a severe burden on engine parts.

Regular exercising keeps engine parts lubricated, prevents oxidation of electrical contacts, and in general helps provide reliable engine starting.

Exercise the set for a minimum of ten minutes off-load at least once a week and for a minimum of 30 minutes with load at least once each month so that the engine reaches normal operating temperatures.

### 5.4.4 Low Operating Temperatures

#### NOTICE

**Operating engines at idle (650 to 1000 rpm) in cold ambient temperatures wastes fuel, accelerates wear, and can result in serious engine damage. Under low temperature conditions, incomplete combustion will occur, allowing deposits of unburned tars and carbon to buildup on the valve guide and valves, and eventually cause valve sticking.**

In cold climates it is critical that the following items be appropriately maintained and selected based on ambient operating temperatures. Check to be sure:

- The battery is properly sized.
- An appropriate mixture of antifreeze is used in the cooling system.
- The proper grade of fuel is being used.
- The correct weight of engine oil is being used.

Use a coolant heater if a separate source of power is available. The optional heater available from Cummins will help provide reliable starting under adverse weather conditions. Make sure the voltage of the separate power source is correct for the heater element rating.

## 5.4.5 High Operating Temperatures

In high ambient temperatures, when operating at full load, it is normal for the high temperature warning to be given. This indicates that the engine is operating near to its maximum capacity and is normal. If operation in high temperature environments is anticipated, increase the frequency of checks for coolant level, obstructions of cooling air inlets and outlets, and debris at the radiator.

Refer to the generator set nameplate for the maximum operating temperature, if applicable.

## 5.4.6 Operating Conditions

### NOTICE

**All generator sets supplied by Cummins must be run under the following operating conditions, and in accordance with the operating information contained within the literature package supplied with each generator set.**

### 5.4.6.1 Continuous Power Rating (COP) for Constant Load Applications

The Continuous Power Rating (COP) is applicable to utility parallel and other non-variable load applications for supplying power continuously to a load of up to 100% of the continuous rating for an unlimited number of hours per year between the stated maintenance intervals and under stated ambient conditions. All maintenance must be carried out as prescribed in Cummins manuals. No overload capability is available at this rating. This rating is applicable for utility base load operation. In these applications, generator sets are operated in parallel with a utility source and run under constant loads for extended periods of time.

### 5.4.6.2 Prime Power Rating (PRP) for Variable Load Applications

The Prime Power Rating (PRP) is the maximum power available during a variable load sequence which may be run for an unlimited number of hours per year, between the stated maintenance intervals and under the stated ambient conditions. All maintenance must be carried out as prescribed in Cummins manuals. Prime power applications fall into one of the following two categories:

- Unlimited time prime power (for variable load applications)

Prime power is available for an unlimited number of annual operating hours in variable load applications. The permissible average power output under variable load shall not exceed a 70% average of the prime power rating during any operation of 250 hours. The total operating time at 100% prime power shall not exceed 500 hours per year. A 10% overload capability is available for a period of 1 hour within a 12-hour period of operation, in accordance with ISO 8528-1 2005. Total operating time at the 10% overload power shall not exceed 25 hours per year.

- Limited running time prime power (for constant load applications) (LTP)

Prime power is available for a limited number of hours in a non-variable load application. It is intended for use in situations where power outages are contracted, such as utility power curtailment. Generator sets may be operated in parallel with the public utility up to 750 hours per year at power levels never to exceed the prime power rating. No sustained overload capability is available at this rating. The customer should be aware, however, that the life of any generator set will be reduced by constant high load operation. Any operation exceeding 750 hours per year at the prime power rating should use the Continuous Power Rating.

---

### 5.4.6.3 Emergency Standby Power Rating (ESP) for Variable Load Applications

The Emergency Standby Power Rating (ESP) is applicable for supplying emergency power for the duration of a utility power interruption, between the stated maintenance intervals and under the stated ambient conditions. All maintenance must be carried out as prescribed in Cummins manuals. No overload capability is available for this rating and utility parallel operation is not permitted at the standby power rating. For applications requiring sustained utility parallel operation, the limited time prime power rating or continuous power rating must be utilized as applicable.

This rating is applicable to installations served by a reliable normal utility source. Generator sets should be sized for a maximum average load factor of 80% of the standby power rating with a maximum of 200 hours of operation per year, which includes less than 25 hours per year at the standby power rating. In installations served by unreliable utility sources (where outages last longer or occur more frequently), where operation is likely to exceed 200 hours per year, the prime power rating should be applied. The standby rating is only applicable for emergency and standby applications where the generator set serves as the back up to the normal utility source. Negotiated power outages are not considered as emergencies.

### 5.4.6.4 Applicable to all Ratings

The following information applies to all ratings, unless otherwise agreed by the Regional Sales Manager of Cummins in writing:

- When determining the actual average power output of a variable power sequence in any of the ratings above, powers of less than 30% of the emergency standby power are taken as 30% and time at no load shall not be counted.
- Variable load is calculated in accordance with methods and formulas given in ISO 8528-1-2005.
- All three-phase generators are rated for 0.8 power factor lag. Single-phase generators are rated for 1.0 power factor.
- All ratings are based on the following reference conditions:
  1. Ambient temperature — 40 °C (104 °F).
  2. Altitude above sea level — 150 meters (490 feet).
  3. Relative humidity — 60%.
  4. Output power may be subject to de-rate if the above conditions are exceeded.
- If any of the above conditions are not satisfied, the operational life of the generating set may be reduced.
- Short term parallel operation with the utility for load transfer purposes only is permitted with all ratings.

### 5.4.7 De-Rating Factors

Engine power and resulting electrical output decrease as ambient temperature or altitude increases. For de-rating factors applicable at specific sites, contact your authorized distributor.

## 5.5 Generator Set Operation

### ⚠ WARNING

#### ***Combustible Vapors***

***Engine over speeding can cause component failure, fire, or an explosion; which can cause severe personal injury or death.***

***Do not operate an engine where there are or can be combustible vapors.***

Correct care of the engine will result in longer life, better performance, and more economical operation.

Numerous safety devices may be available, such as air intake shutoff devices, to minimize the risk of overspeeding in which an engine, because of application, might operate in a combustible environment (from a fuel spill or gas leak, for example). Cummins does not know how the engine will be used. The equipment owner and operator, therefore, is responsible for safe operation in a hostile environment. Consult your authorized distributor for further information.

### NOTICE

**Cummins recommends the installation of an air intake shutoff device or a similar safety device to minimize the risk of overspeeding where an engine will be operated in a combustible environment.**

### NOTICE

**Long periods of idling (more than ten minutes) can damage an engine. Do not idle the engine for excessively long periods.**

### 5.5.1 Sequence of Operation

The generator set is run automatically using a **Remote Start** signal, or manually using the generator set control panel buttons. LEDs are provided on the operator panel to indicate the operating run mode of the generator set. The PowerCommand® control initiates a starter cranking signal and performs an automatically sequenced manual start, under a complete engine protection system combined with full monitoring capability. If a fault is sensed at start-up, the engine is locked out and will not start.

The choice of **Auto** or **Manual Run** mode is decided by authorized personnel during the generator set initial setup. An access code is required to switch between the **Auto**, **Manual Run**, or **Off** modes, and this facility may be permitted or denied by the authorized personnel during the initial setup of the generator set.

## 5.6 Before Starting

### NOTICE

**One operator should be in complete charge, or working under the direction of someone who is in charge. Remember that, upon starting the engine, cables and switchgear will become energized, possibly for the first time. Furthermore, equipment that does not form part of the generator set installation may become electrically charged. Only authorized and competent personnel should carry out this work.**

**NOTICE**

**Do not use the Emergency Stop button to shut down an engine unless a serious fault develops. The Emergency Stop button must not be used for a normal shut-down as this will prevent a cooling down run in which the lubricating oil and engine coolant carry the heat away from the engine combustion chamber and bearings in a safe manner.**

**NOTICE**

***Diesel engines only:* Avoid off-load running for other than short periods. A minimum loading of 30% is recommended. The engine must be shut down as soon as possible after the appropriate functions have been checked.**

**NOTICE**

***Gaseous engines only:* Avoid running the generator set at no-load and light-loads for extended periods.**

Before attempting to start the generator set, the operator should read through this entire manual and the specific literature provided as part of the documentation pack supplied with the generator set. It is essential that the operator be completely familiar with the generator set and the PowerCommand® control.

The sub-sections below cover the systems used to start and stop the generator set.

Before starting the generator set, make sure that exhaust and fuel fittings are tight and properly positioned, and that proper maintenance and pre-start checks have been performed.

During starting, automatic checks are carried out for the integrity of various protection systems. The PowerCommand® control will not allow the generator set to continue the starting sequence if the integrity of a sensor is considered to be in doubt.

The generator set can be configured for a number of starting cycles (one to seven) with set times for crank and rest periods for all starting modes (manual/remote). The default setting is for three start cycles, composed of fifteen seconds of cranking and 30 seconds of rest.

**NOTICE**

**The number of starting cycles, and the crank and rest times are set from within the Setup menu. Trained and experienced service personnel are required to change the default setting. Contact your authorized Cummins distributor.**

## 5.6.1 Initial Pre-Start Checks

**⚠ WARNING*****Electric Shock Hazard***

***Voltages and currents present an electrical shock hazard that can cause severe burns or death. Make sure that only personnel who are trained and experienced work with distribution voltages. Even after generator set shutdown, an electrical shock hazard may still exist, caused by induced or residual voltage within the alternator or cables. Some interfaces may display zero voltage even when voltages are present.***

<b>⚠ WARNING</b>
<p><b>Hot Pressurized Liquid</b>  <b>Contact with hot liquid can cause severe burns.</b>  <b>Do not open the pressure cap while the engine is running. Let the engine cool down before removing the cap. Turn the cap slowly and do not open it fully until the pressure has been relieved.</b></p>

Before starting, competent personnel must make the following checks to make sure that the unit is ready for operation:

**TABLE 18. INITIAL PRE-START CHECKS**

Check	Description
Generator Set Grounding	Grounding (earthing) must be checked prior to performing service or inspection procedures that may expose personnel to conductors normally energized with voltages greater than 600 Volts. Contact your authorized Cummins distributor.
Insulation Testing <sup>1</sup>	This must be performed on all generator sets before initial start-up and after the generator set grounding procedure has been completed. Insulation testing for low voltage (less than 600 Volts) generator sets is recommended by Cummins. These tests are used to verify that the windings are dry before the generator set is operated, and to develop a base line for future test comparisons. Contact your authorized Cummins distributor.
Lubrication <sup>2</sup>	Check the engine lubrication oil level and ensure that the correct level is always maintained.
Coolant <sup>3,4,5</sup>	Check the engine coolant level and ensure that the level is always maintained. Fill the cooling system to the bottom of the fill neck in the radiator fill or expansion tank. Do not check the level while the engine is hot.

<sup>1</sup>When wire insulation-testing an alternator, failure to protect the voltage regulator, control and diodes could result in permanent damage to one or more of the electronic components.  
<sup>2</sup>Generator sets shipped dry only: They must be filled with the correct type and quantity of oil before use. Be sure to check the oil level before initial start. Failure to fill to the recommended level can result in equipment damage.  
<sup>3</sup>Generator sets that require a mix of anti-freeze and DCA inhibitor only: You must comply with Cummins requirements for the correct type and concentration of anti-freeze and DCA inhibitor. Warranty claims for damage will be rejected if the incorrect mix is used. Consult your authorized Cummins distributor for the correct anti-freeze specifications and concentration for your operating conditions.  
<sup>4</sup>Radiators with two fill necks only: Both fill necks must be filled after the cooling system has been drained.  
<sup>5</sup>Generator sets shipped dry only: The engine must be filled with the correct type and quantity of coolant before use. Be sure to check coolant level(s), before the initial start.

### 5.6.2 Operator’s Pre-Start Checks

<b>⚠ WARNING</b>
<p><b>Arc Flash and Shock Hazard</b>  <b>Electric arc flash can cause electrical shock, severe burns, or death.</b>  <b>Make sure the alternator is dry before the generator set is operated.</b></p>

<b>⚠ WARNING</b>
<p><b>Hot Pressurized Liquid</b>  <b>Contact with hot liquid can cause severe burns.</b>  <b>Do not open the pressure cap while the engine is running. Let the engine cool down before removing the cap. Turn the cap slowly and do not open it fully until the pressure has been relieved.</b></p>

<b>NOTICE</b>
<p><b>Radiators with two fill necks only: Both fill necks must be filled when the cooling system has been drained.</b></p>

**TABLE 19. OPERATOR’S PRE-START CHECKS**

Check	Description
Fuel Supply ( <i>Diesel Only</i> )	<p>Make sure that:</p> <ul style="list-style-type: none"> <li>• The fuel tank is filled to the normal level with clean water-free fuel and that the fuel system is primed;</li> <li>• All the valves required for operation are open;</li> <li>• There are no leaks and that all fittings are tight; and</li> <li>• If equipped, the auxiliary fuel system is properly connected.</li> </ul>
DEF Supply ( <i>If Equipped</i> )	<p>Make sure that:</p> <ul style="list-style-type: none"> <li>• The DEF tank is filled to the normal full level with DEF, and</li> <li>• If equipped, the auxiliary DEF system is properly connected.</li> </ul>
Lubrication	With the engine stationary, check the engine lubrication oil level and make sure that the correct level is always maintained.
Coolant	Check the engine coolant level and make sure that the level is always maintained at the coolant expansion tank. Fill the cooling system to the bottom of the fill neck in the radiator fill or expansion tank. Do not check while the engine is hot.
Cooling Air Inlet/Outlets	Make sure that the cooling air inlets/outlets are unobstructed.
Exhaust Outlet	<p>Make sure that:</p> <ul style="list-style-type: none"> <li>• Exhaust components are secured and not warped;</li> <li>• The exhaust outlet is unobstructed;</li> <li>• No combustible materials are near the system;</li> <li>• Gases are discharged away from building openings; and</li> <li>• There are no leaks and that all fittings are tight.</li> </ul>
Batteries	Make sure that the batteries are charged, and that all connections are clean, correct and tight (if applicable).
Auxiliary Powered AC Supplies	Make sure that all auxiliary equipment is receiving power from the customer’s supply.
Emergency Stop	Make sure that the emergency stop button is fully operational.

### 5.6.3 Starting at Operator Panel (Manual Run Mode)

#### NOTICE

Make sure that all Pre-start Checks are carried out before starting the generator set. Do not attempt to start the generator set until it is safe to do so. Warn all others in the vicinity of the generator set and the connected load equipment that the generator set is about to start.

1. Make sure the main circuit breaker is in the open position.

2. To start the generator set in the **Manual Run** mode, press the **Manual** button  on the Operator



Panel, and then press the **Start** button  within ten seconds. Failure to press the **Start** button within this time will result in the generator set changing to the **Off** mode. (Refer also to [Section 4.12.2 on page 75](#)).

#### NOTICE

If the mode change access code feature has been enabled, enter the access code when prompted. (See [Section 4.12.1 on page 74](#)).

The PowerCommand® control will initiate a starter cranking signal and will perform an automatically sequenced manual start, under a complete engine protection system combined with full monitoring capability. This will activate the engine control system and the starting procedure. The starter will begin cranking, and after a few seconds the engine will start and the starter will disconnect.

Should the engine fail to start, the starter will disengage after a specified period of time and the control will indicate a Fail to Start shutdown.

To clear a Fail to Start shutdown, press the **Stop** button  and then press the **Reset** button.  Before attempting to re-start wait a minimum of two minutes for the starter motor to cool and then repeat the starting procedure. If the engine does not run after a second attempt, refer to [Chapter 7](#).

To disable **Manual** mode, change to **Auto** or **Off** mode. If the generator set is running when it leaves **Manual** mode, it will continue to run if **Auto** mode has been selected and the remote start signal is active. If there is no active remote start signal, the generator set will stop.

3. Allow the engine to warm up and reach the rated speed and voltage.

4. Close the main circuit breaker and apply load as required.

### 5.6.4 Starting from Remote Location (Auto Mode)

#### NOTICE

Make sure that all Pre-start Checks are carried out before starting the generator set. Do not attempt to start the generator set until it is safe to do so. Warn all others in the vicinity that the generator set is about to start.

To start the generator set in the **Auto Run** mode, select the **Auto** button  from the Operator Panel. (Refer also to [Section 4.12.3 on page 75](#)).

Only on receipt of a remote start signal, and after a Time Delay to Start, will the PowerCommand® control initiate the starting sequence as above.

The Remote Start LED will be lit.

There are two start modes that are selectable for the Remote Start input; one for non-emergency start and the other for emergency start. In the non-emergency start, the control will complete the warm-up at idle. In the emergency mode, the generator set will omit the warm-up stage and proceed directly to rated speed and voltage.

In response to the Remote Start signal, or the control detects the loss of the Utility voltage, the control lights the Remote Start indicator and initiates the starting sequence, except for the following:

- In Auto position, the control will complete the Time Delay to Start (0 to 300 seconds) for a non-emergency start signal only.

#### NOTICE

**If the mode change access code feature has been enabled, enter the access code when prompted. (See [Section 4.12.1 on page 74](#))**

To disable **Auto** mode, change to **Manual** or **Stop** mode. Refer to [Section 5.7 on page 87](#).

## 5.6.5 Cold Starting with Loads

#### NOTICE

**Make sure that all pre-start checks are carried out before starting the generator set. Do not attempt to start the generator set until it is safe to do so. Warn all others in the vicinity that the generator set is about to start.**

Use a coolant heater if a separate source of power is available. The optional heater available from Cummins will help provide reliable starting under adverse weather conditions. Be sure the voltage of the separate power source is correct for the heater element rating.

Cummins recommends equipping standby generator sets (life safety systems) with engine water jacket coolant heaters to maintain the coolant at a minimum of 32 °C (90 °F) and, for most applications, accept the emergency load in ten seconds or less. Although most Cummins generator sets will start in temperatures down to -32 °C (-25 °F) when equipped with engine water jacket coolant heaters, it might take more than ten seconds to warm the engine up before a load can be applied when ambient temperatures are below 4 °C (40 °F).

The **Low Coolant Temp** (Code 1435) message along with the lighting of the **Warning** LED are provided to alert the operator of a possible delay in accepting the load. The engine cold sensing logic initiates a warning when the engine water jacket coolant temperature falls below 21 °C (70 °F). In applications where the ambient temperature falls below 4 °C (40 °F), a cold engine may be indicated even though the coolant heaters are connected and functioning correctly. Under these conditions, although the generator set may start, it may not be able to accept load within ten seconds. When this condition occurs, check the coolant heaters for correct operation. If the coolant heaters are operating correctly, other precautions may be necessary to warm the engine before applying a load.

### 5.6.5.1 Checking Coolant Heater Operation

#### WARNING

##### *Hot Surfaces*

**Contact with the hot surfaces can cause severe burns.**

**Avoid contact with hot parts. Allow hot parts to completely cool.**

Do not touch the cooling system outlet hose. The coolant heater is operating if radiant heat can be felt with your hand held close to the outlet hose and the engine is not running.

## 5.7 Stopping

### NOTICE

The access code may be required before initiating the Off button sequence. See the Passwords and Mode Change Access section.

### NOTICE

Run the generator set at no load for three to five minutes before stopping. This allows the lubricating oil and engine coolant to carry heat away from the combustion chamber and bearings.

### 5.7.1 Stopping at the Operator Panel (Manual Mode)

#### NOTICE

If possible, hot shutdown under load should be avoided to help prolong the reliability of the set. A hot shutdown results in a Hot Shutdown Warning.

#### NOTICE

Hot shutdown under load should be avoided whenever possible to prolong the reliability of the set. A hot shutdown may result in a Hot Shutdown Warning.

#### NOTICE

Pressing the stop button twice stops the generator set immediately without a cool down run after which the set enters the off mode.

To shut down a generator set that was started in manual mode.

1. Remove the load.
2. Open the main circuit breaker.
3. Press the stop button on the HMI operator panel. This initiates the generator set cool down run. The HMI displays the cool down count down timer at this time. Once the cool down timer has expired, the generator set shuts off and enters off mode.

### 5.7.2 Stopping from Operator Panel (Auto Mode)

If the generator set was started in **Auto** mode, press the **Stop** button  once to stop the generator set immediately, without a Cooldown run, after which the generator set will enter the **Off** mode.

If possible re-start the generator set in **Manual** mode with the circuit breaker open, and allow to stop with a Cooldown run.

**NOTICE**

*If possible, hot shutdown under load should be avoided to help prolong the reliability of the set. A hot shutdown will result in a Hot Shutdown Warning.*

**NOTICE**

**When MLD is enabled, stopping a generator set may cause one or more stopped generator sets to start.**

### 5.7.3 Stopping from Remote Location (Auto Mode)

If the control receives a remote stop signal, the generator set completes its normal shutdown sequence incorporating a Cooldown run (Refer to [Section 4.12.3](#)). (The remote stop signal is actually the removal of the remote start signal to the control).

The generator set will stop after completing the following Cooldown sequence:

- Time Delay to Stop function (zero to 600 seconds)
- Cooldown at Idle (zero to ten minutes) or longer, if necessary to obtain normal operating temperature before shutdown.

The set will remain in the **Auto** mode, and subject to a remote start signal, unless the **Stop** button is pressed. If this button is pressed the set will enter the **Off** mode.

**NOTICE**

*The InPower service tool or access to the Setup menus is required to enable and change the time delay start/stop settings. Contact your authorized distributor for assistance.*

### 5.7.4 Code 1433 or 1434 - Emergency Stop

The local **Emergency Stop** button is situated on the front of the operator panel. This is a mechanically latched switch that will unconditionally stop the engine when pressed, bypassing any time delay to stop. Push this button for emergency shutdown of the engine.

**NOTICE**

**If the engine is not running, pushing the button will prevent the starting of the engine, regardless of the start signal source (Manual or Auto - Remote).**

When the **Stop** button is pressed, the display will indicate the shutdown condition by illuminating the red

**Shutdown** status LED  and displaying the following message on the graphical LCD display:

- Fault Number: 1433 LOCAL EMERGENCY STOP

A remote **Emergency Stop** button may be incorporated within the installation. If this remote **Emergency Stop** button is activated, the following message will be displayed:

- Fault Number: 1434 REMOTE EMERGENCY STOP

To reset:

1. Pull, or twist and pull the button out.
2. Press the **Stop** button on the operator panel to acknowledge this action.

3. Press the **Reset** button.
4. Press the **Auto** or **Manual Run** button, as previously determined. See the Selecting Operating Modes section.

**NOTICE**

**Do not use an Emergency Stop button to shut down an engine unless a serious fault develops. The Emergency Stop button must not be used for a normal shut-down because this will prevent a cooling down run in which the lubricating oil and engine coolant safely carry away heat from the engine combustion chamber and bearings.**

**NOTICE**

**Make sure that the cause of the Emergency Stop is fully investigated and remedied before a fault Reset and generator set Start are attempted.**

**NOTICE**

**An Emergency Stop button is situated in close proximity to the operator panel viewing window.**

## 5.8 Paralleling Operation

### 5.8.1 Speed and Voltage Matching

Once the generator set has achieved nominal voltage and frequency, the set is ready to be paralleled with the busbar supply. Each generator set is paralleled completely independently of any others.

The PowerCommand® 3.3 control unit monitors both the incoming supply and the busbar voltage and frequency. It adjusts the incoming supply to match the busbar supply over a wide span of busbar parameters. Synchronization is achieved under full control and at the correct phase coincidence.

In Automatic mode, the PowerCommand® 3.3 control receives a breaker close signal when synchronization has been achieved, and signals the main breaker to close. In Manual mode, the main breaker is closed to connect the generator set to the busbars by using the breaker Close button.

**NOTICE**

**The PowerCommand® 3.3 control performs a synchronization check in both Manual and Auto modes before allowing the generator set circuit breaker to close.**

### 5.8.2 Operation When in Parallel

When in parallel with the busbar supply, the generator set voltage and frequency are dependent upon the busbar parameters and the control is changed to kW and kVAR load management.

Each generator set is individually controlled by a separate PowerCommand® 3.3 control.

Apart from the protection systems, there is no common coupling between generator sets. This allows for any set, or its relevant controls, to be under maintenance without affecting the others.

When the control system detects that the generator set is up to speed and voltage, the load ramps from the mains to the generator set. The engine governor control system keeps the electrical output within the correct parameters.

### 5.8.3 Generator Set Application Type

The generator set application type is the primary setting for configuring the paralleling features of the PowerCommand® 3.3 control. [Table 20](#) provides more information about each generator set application type. It indicates how the generator set can run in parallel, what paralleling states or processes are available together, and how much control the PowerCommand® 3.3 control over the circuit breakers.

**TABLE 20. OVERVIEW OF GENERATOR SET APPLICATION STATES**

Paralleling	Generator Set Application Types					
	Standalone	Synchronizer Only	Isolated Bus Only	Utility Single	Utility Multiple	Power Transfer Control
Parallel Process with Utility				■	■	■
Parallel Process with Other Generator Sets			■		■	
Paralleling States:						
• Standby	■	■	■	■	■	■
• Dead Bus/ First Start			■	■	■	
• Synchronize		■	■	■	■	■
• Load Share			■		■	
• Load Govern				■	■	■
• Masterless Load Demand (MLD)			■			
• Generator Set CB Trip	■	■				
• Generator Set CB Control			■	■	■	■
• Utility CB Control						■

In general, generator set application types are distinguished by what may be run in parallel with the generator set. Synchronizer Only and Power Transfer Control are further distinguished by other characteristics as follows:

- *Synchronizer Only:* The generator set is not running in parallel with other generator sets or with the utility, but the PowerCommand® 3.3 control can synchronize its voltage, frequency and phase with one other power source. This is typically for use in applications with transfer switches which use fast-close transitions but do not have a built in synchronizer.
- *In Power Transfer Control:* The PowerCommand® 3.3 controls the generator set's circuit breaker and utility circuit breaker to ensure the load has power. The PowerCommand® 3.3 control does not control the utility circuit breaker in any other generator set application type.

**NOTICE**

**The PowerCommand® 3.3 control does not support paralleling in a Single-Phase configuration. If Single/3-Phase Configuration is set to Single-Phase, the generator set application type is Standalone.**

### 5.8.4 Standalone Application

In the generator set application shown in [Figure 37](#), the generator set is not running in parallel with other sets or with the utility. The controller is always in the Standby state and may be in either the Power On or Sleep mode.

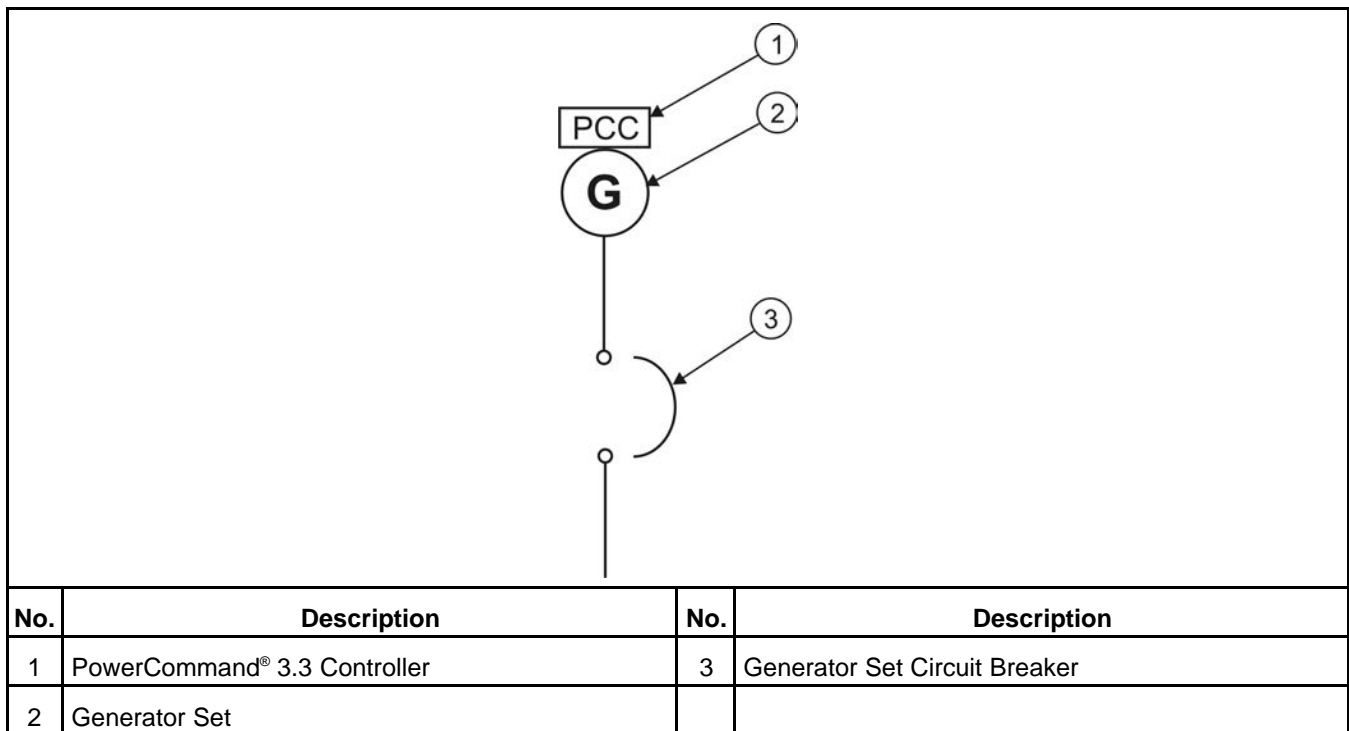
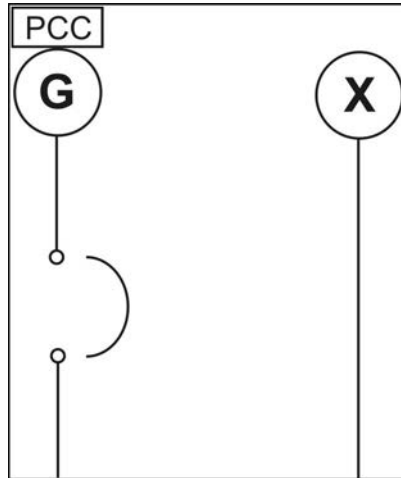

**FIGURE 37. STANDALONE**

When the generator set is required to accept a load, the generator set must be started in either Manual or Auto mode. When the set has run up to speed, the circuit breaker must be closed in either the Manual or Auto mode to accept the load.

## 5.8.5 Synchronize Only

In the generator set application shown in [Figure 38](#), the generator set is not running in parallel with other sets or with the utility, but the PowerCommand® 3.3 control can synchronize the voltage, frequency and phase with one other power source. This is typically used in applications with transfer switches that use fast-close transitions but do not have a built in synchronizer.



**FIGURE 38. SYNCHRONIZED ONLY**

The PowerCommand® 3.3 control is in the Standby paralleling state until event 1465 (Ready to Load) is active. Then the PowerCommand® 3.3 control synchronizes if all of the following conditions are met:

- The sync enable signal is active.
- The synchronizer conditions are met.

If any of these conditions are not met the PowerCommand® 3.3 control remains in the Standby paralleling state.

The Sync Enable Signal may come from the PowerCommand® 3.3 control's Sync Enable connection or Modbus networks. This signal becomes active when any of these sources are present and remains active until any of these conditions are changed. When this signal becomes active the PowerCommand® 3.3 control synchronizes with the live bus.

## 5.8.6 Isolated Bus Only

In the generator set application shown in [Figure 39](#), the generator set is running in parallel with other generator sets.

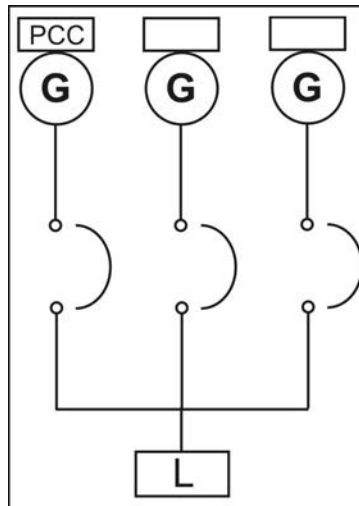

**FIGURE 39. ISOLATED BUS ONLY – STANDBY PARALLELING STATE**

The generator set is in the Standby paralleling state until event 1465 (Ready to Load) is active. The PowerCommand® 3.3 control then considers the current position of the generator set circuit breaker.

Before the PowerCommand® 3.3 control closes the generator set circuit breaker, all of the following conditions must be met:

- Initially the First Start process determines whether or not to close the generator set circuit breaker onto a dead bus when it is in parallel with other generator sets (provided the sets are in Auto setup).
- The generator set circuit breaker is then closed if the following conditions are met:
  1. There are no generator set circuit breaker Open requests.
  2. There is a generator set circuit breaker Close request.

If the PowerCommand® 3.3 control is in Manual mode, the CB Close button must be pressed.

#### **NOTICE**

***The PowerCommand® 3.3 control inhibits closure of the paralleling breaker outside the sync-check window. Therefore the breaker close button can be operated even before synchronization, although the breaker will not close until a signal is sent from the PowerCommand® 3.3 control to allow it.***

When all the above conditions are met and the generator set circuit breaker is closed, the generator set will parallel with the other generator sets to share the load.

In [Figure 40](#) the PowerCommand® 3.3 control is now in the Load Share paralleling state, all of the generator sets' circuit breakers are closed, so the load is now receiving power from all sources.

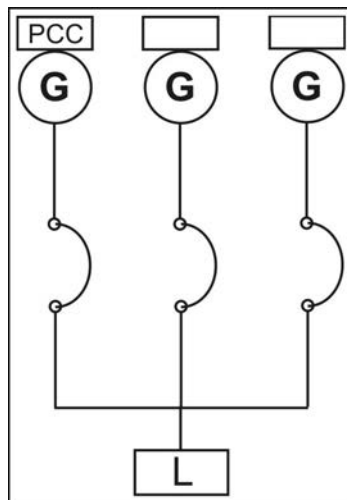

**FIGURE 40. ISOLATED BUS ONLY - LOAD SHARE PARALLELING STATE**

Open the generator set circuit breaker if there are any generator set circuit breaker Open requests. This will place the generator set back into the Standby paralleling state and therefore will no longer supply power to the load.

## 5.8.7 Conditions for Each Paralleling State

### 5.8.7.1 Utility Single

In this application, the generator is running in parallel with the utility. There are no other generators employed in this type of system.

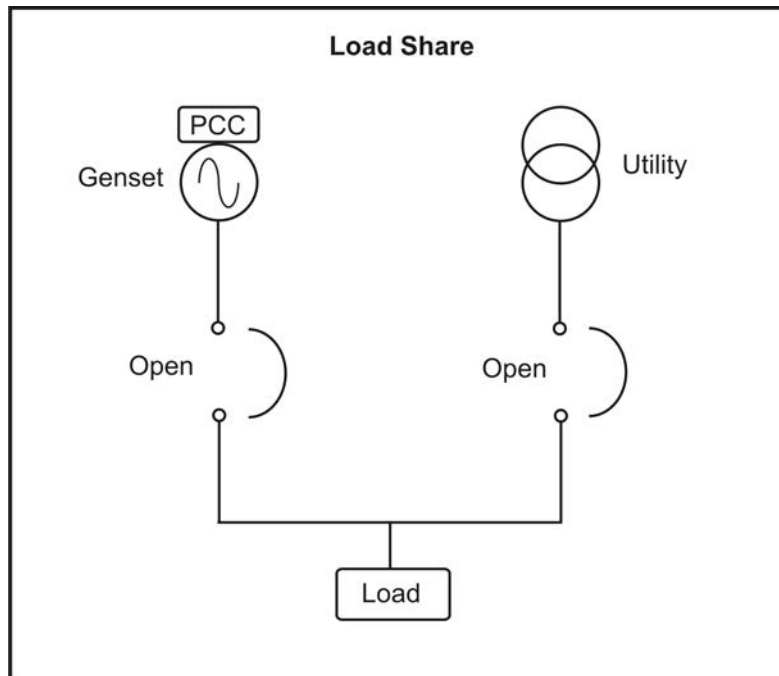

**FIGURE 41. UTILITY - SINGLE MODE**

The generator set is in the Standby paralleling state until event 1465 (Ready to Load) is active. The controller then considers the current position of both the generator set and the utility circuit breakers, as illustrated in [Figure 41 on page 94](#).

[Figure 42 on page 95](#), [Figure 43 on page 96](#), [Figure 44 on page 97](#) and [Figure 45 on page 98](#) illustrate the various conditions for each paralleling state.

### NOTICE

***In the following sequences, the PowerCommand® 3.3 control must be in the Standby Paralleling state unless otherwise stated and assumes that the PowerCommand® 3.3 control menus have been set with the correct paralleling parameters.***

In [Figure 42 on page 95](#), the circuit breakers on both the generator and utility are open. The generator is running and power from the Utility is available. In this condition, the load is receiving no power from either source.

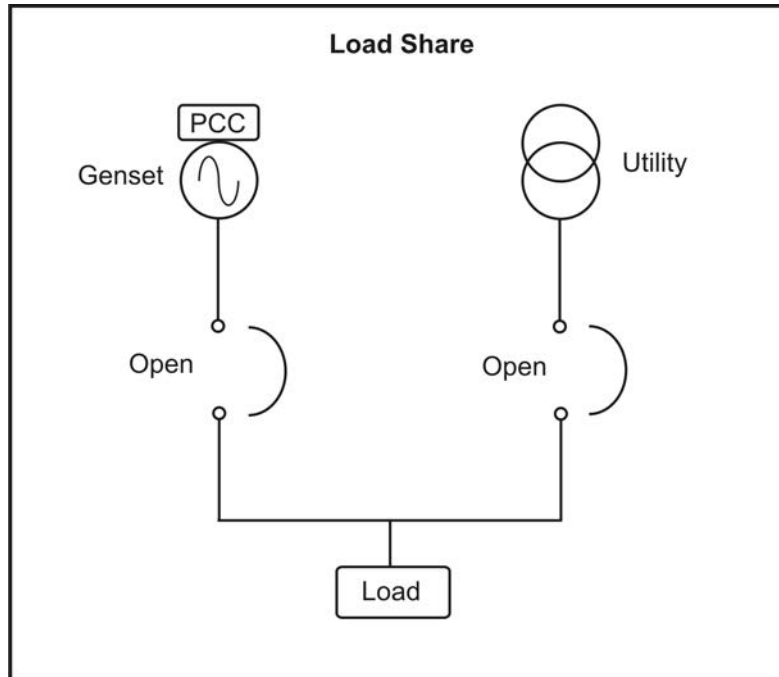

**FIGURE 42. UTILITY SINGLE – SEQUENCE 1**

Before the PowerCommand® 3.3 control closes the generator set circuit breaker, all of the following conditions must be met:

- There is a generator set circuit breaker Close request.
- There are no generator set circuit breaker Open requests.
- Utility Single Mode Verify/Configurable Input #29 Function Pointer is set to Default.
- Configurable Input #29 is active.

If the PowerCommand® 3.3 control is in Manual mode, the circuit breaker Close button must be pressed.

The generator set will then provide power for the load.

### NOTICE

***The PowerCommand® 3.3 control inhibits closure of the paralleling breaker outside the sync-check window. Therefore, the breaker close button can be operated even before synchronization, although the breaker will not close until a signal is sent from the PowerCommand® 3.3 control to allow it.***

In [Figure 43 on page 96](#), the generator set is running with the circuit breaker open and the utility circuit breaker closed, providing power for the load.

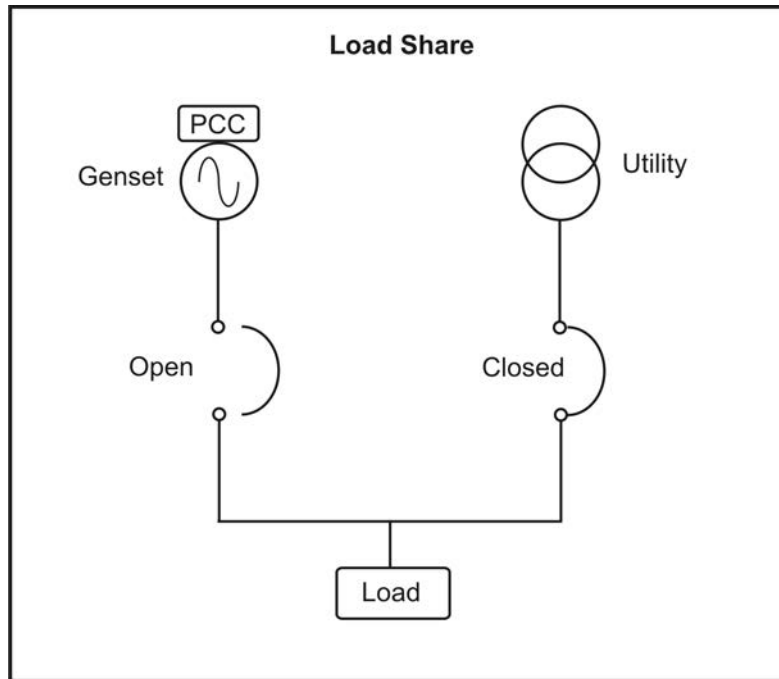

**FIGURE 43. UTILITY SINGLE – SEQUENCE 2**

The PowerCommand® 3.3 control will automatically initiate the Synchronize procedure, since it is synchronizing to the utility.

Before the PowerCommand® 3.3 control closes the generator set circuit breaker, both of the following conditions must be met:

- There are no generator set circuit breaker Open requests.
- There is a generator set circuit breaker Close request.

If the PowerCommand® 3.3 control is in Manual mode, the circuit breaker Close button must be pressed. The generator set will then load share with the utility.

In [Figure 44 on page 97](#), the utility circuit breaker is Open and the generator set is running with the circuit breaker closed, providing power for the load.

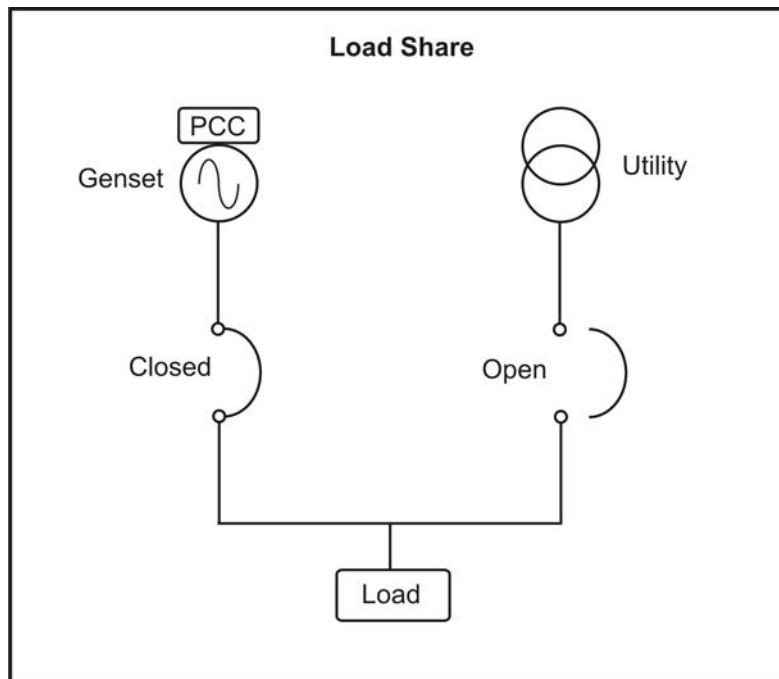

**FIGURE 44. UTILITY SINGLE – SEQUENCE 3**

When the utility is available, its circuit breaker may be closed and therefore available to supply power to the load. The generator set circuit breaker may then be opened, returning the generator set to the Standby paralleling state. The generator set will therefore no longer supply power to the load.

The Sync Enable input must be closed to enable the synchronizer, thereby allowing a re-transfer of load back to the utility.

**NOTICE**

**Utility CB sync check and utility breaker controls are not part of the PowerCommand@3.3 control system.**

**NOTICE**

**In Manual mode, it will be necessary to press the CB Open button on the operator panel.**

In this condition (see [Figure 45 on page 98](#)), the PowerCommand® 3.3 control is now in the Load Govern paralleling state. Both the generator and utility circuit breakers are closed; therefore, the load is now receiving power from both sources.

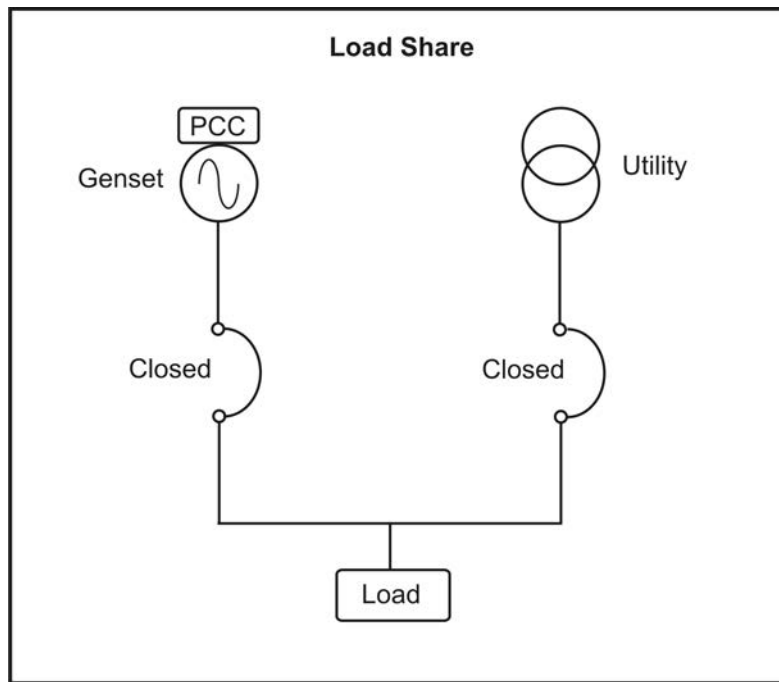

**FIGURE 45. UTILITY SINGLE – SEQUENCE 4**

Open the generator set circuit breaker if there are any generator set circuit breaker Open requests.

### 5.8.7.2 Utility Multiple

#### **NOTICE**

**For paralleling with a PC 3.3 Controller and Motorised Circuit Breaker, to avoid false tripping of the circuit breaker it is recommended to switch off the earth fault protection. The earth fault protection switch is located on the control panel.**

In the generator set application shown in [Figure 46 on page 99](#), the generator set is running in parallel with other generator sets which in turn are running in parallel with the utility.

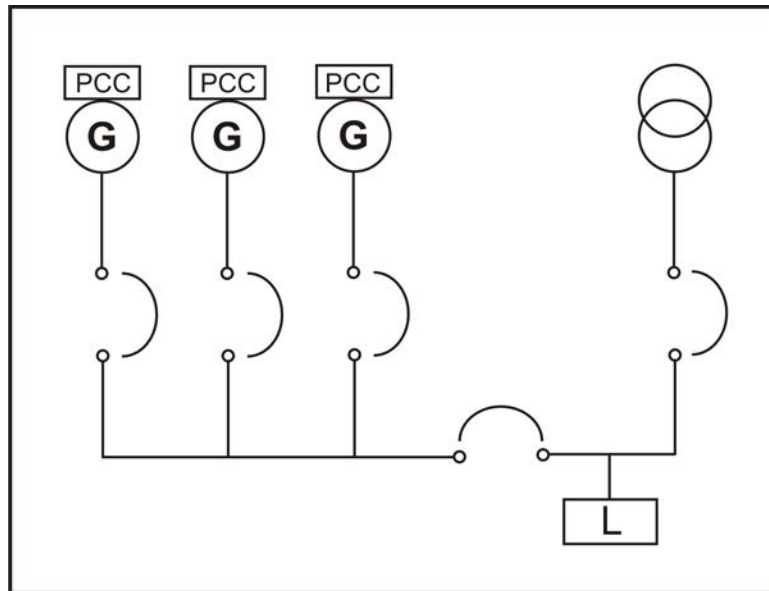

**FIGURE 46. UTILITY MULTIPLE**

The PowerCommand® 3.3 control is in the Standby paralleling state until Event 1465 (Ready to Load) is active. The PowerCommand® 3.3 control then considers the current position of the generator set circuit breaker and the utility circuit breaker, as illustrated in [Figure 46 on page 99](#). To ensure a seamless transfer of the load between the utility and generator set(s), a closed transition transfer switch is incorporated.

The generator sets may be in Auto or Manual setup. If in Auto setup, the First Start process will be available to enable a generator set to close the circuit breaker onto a dead bus. The remaining generator sets then wait for the bus to go live before synchronizing to it.

[Figure 47 on page 100](#), [Figure 48 on page 101](#), [Figure 49 on page 101](#) and [Figure 50 on page 102](#) illustrate the various conditions for each paralleling state.

#### NOTICE

**In the following sequences, the PowerCommand® 3.3 control must be in the Standby Paralleling State unless otherwise stated and assumes that the PowerCommand® 3.3 control menus have been set with the correct paralleling parameters.**

In [Figure 47 on page 100](#), the circuit breakers on both the generator and utility are open. The generator is running and power from the Utility is available. In this condition the load is receiving no power from either source.

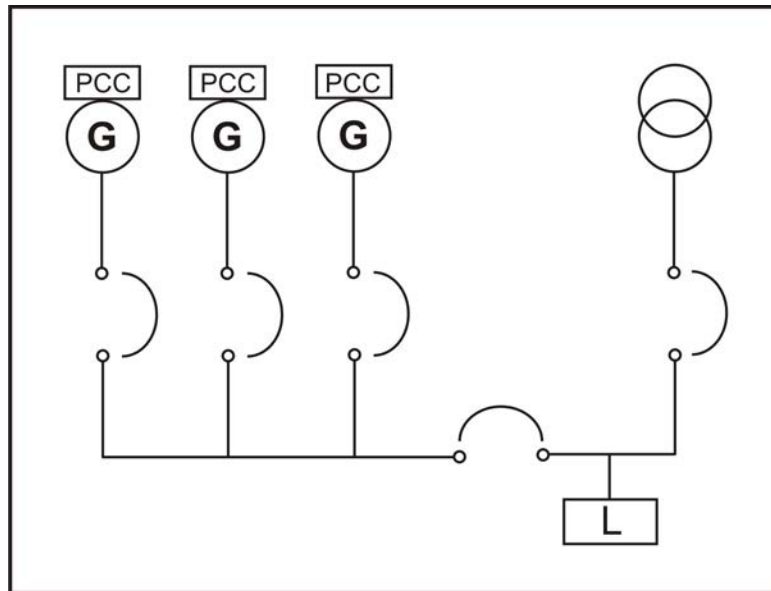

**FIGURE 47. UTILITY MULTIPLE – SEQUENCE 1**

Before the PowerCommand® 3.3 control closes the generator set circuit breaker, all of the following conditions must be met:

- Initially the First Start process determines whether or not to close the generator set circuit breaker onto a dead bus when it is in parallel with other generator sets (provided the sets are in Auto setup).
- The generator set circuit breaker is then closed if the following conditions are met:
  1. There are no generator set circuit breaker Open requests.
  2. There is a generator set circuit breaker Close request.

If the PowerCommand® 3.3 control is in Manual mode, the circuit breaker Close button must be pressed.

#### **NOTICE**

**The PowerCommand® 3.3 control inhibits closure of the paralleling breaker outside the sync-check window. Therefore, the breaker close button can be operated even before synchronization, although the breaker will not close until a signal is sent from the PowerCommand® 3.3 control to allow it.**

When all the above conditions are met and the generator set circuit breaker is Closed, the generator set will parallel with the other generator sets and/or the utility to share the load.

In [Figure 48 on page 101](#), the generator set is running with the circuit breaker open and the utility circuit breaker closed, providing power for the load.

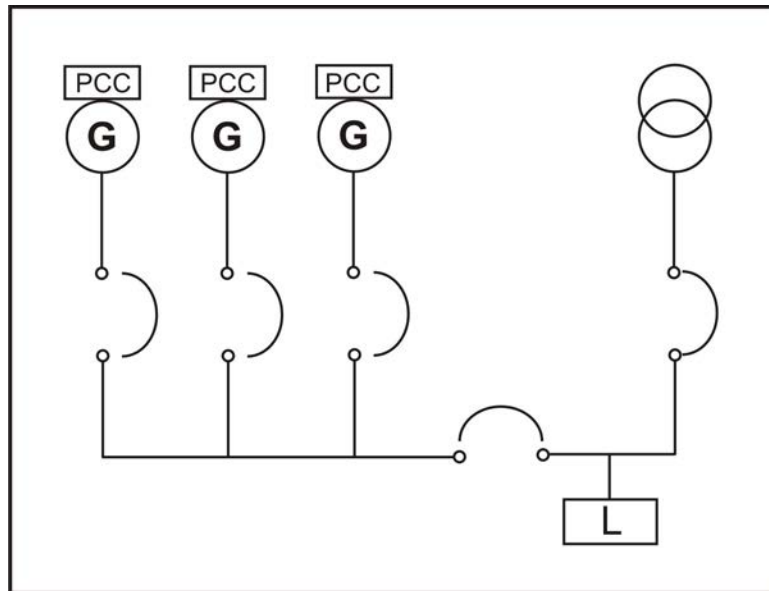

**FIGURE 48. UTILITY MULTIPLE – SEQUENCE 2**

The PowerCommand® 3.3 control will automatically initiate the Synchronize procedure since it is synchronizing to the utility.

Before the PowerCommand® 3.3 control closes the generator set circuit breaker, all of the following conditions must be met:

- There are no generator set circuit breaker Open requests.
- There is a generator set circuit breaker Close request.

If the PowerCommand® 3.3 control is in Manual mode, the circuit breaker Close button must be pressed. The generator set will then load share with the utility.

In [Figure 49 on page 101](#), the utility circuit breaker is Open and a generator set is running with the circuit breaker Closed, providing power for the load.

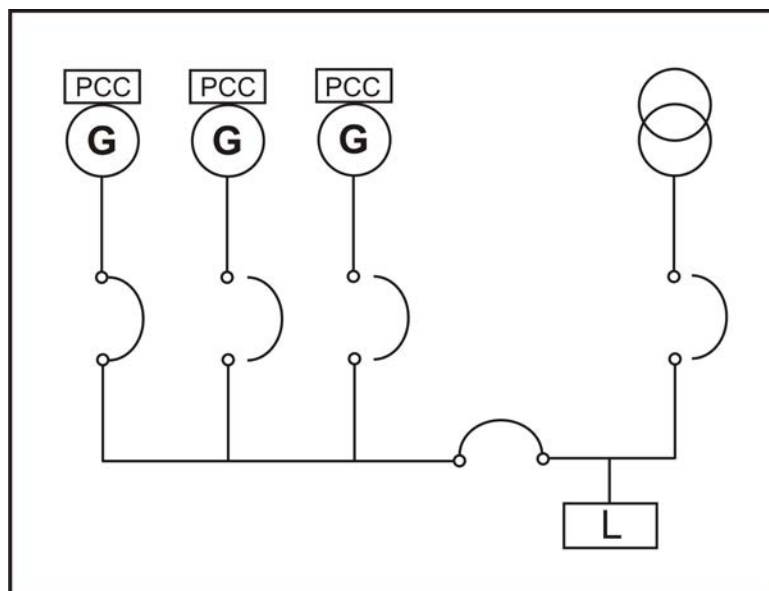

**FIGURE 49. UTILITY MULTIPLE - SEQUENCE 3**

When the utility is again available to supply the load, open the generator set circuit breaker if there are any generator set circuit breaker Open requests. This will place the generator set back into the Standby paralleling state and therefore will no longer supply power to the load.

In [Figure 50 on page 102](#), the PowerCommand® 3.3 control is now in the Load Govern paralleling state. Both the generator and utility circuit breakers are closed, so the load is now receiving power from both sources.

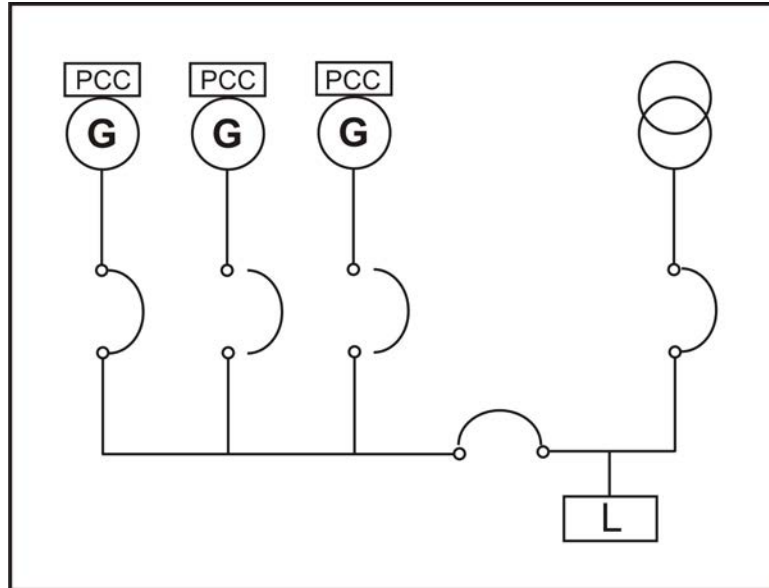

**FIGURE 50. UTILITY MULTIPLE - SEQUENCE 4**

Open the generator set circuit breaker if there are any generator set circuit breaker Open requests. This will place the generator set back into the Standby paralleling state and therefore will no longer supply power to the load.

# 6 Maintenance

---

## WARNING

### ***Automated Machinery***

***Accidental or remote starting of the generator set can cause severe personal injury or death. Make sure that the generator set cannot be started accidentally or remotely before starting work on the generator.***

## WARNING

### ***Fall Hazard***

***Falls can result in severe personal injury or death. Make sure that suitable equipment for performing tasks at height are used in accordance with local guidelines and legislation.***

## WARNING

### ***Mechanical Hazard***

***Failed components may be ejected or operate incorrectly which can cause severe personal injury or death. Do not climb the generator set; this may damage critical parts.***

## WARNING

### ***Combustible Gases***

***Ignition of battery gases is a fire and explosion hazard which can cause severe personal injury or death. Do not smoke, or switch the trouble light ON or OFF near a battery. Touch a grounded metal surface first before touching batteries to discharge static electricity. Stop the generator set and disconnect the battery charger before disconnecting battery cables. Using an insulated wrench, disconnect the negative (-) cable first and reconnect it last.***

## WARNING

### ***Electric Shock Hazard***

***Voltages and currents present an electrical shock hazard that can cause severe burns or death. Make sure that only personnel who are trained and experienced work with distribution voltages. Even after generator set shutdown, an electrical shock hazard may still exist, caused by induced or residual voltage within the alternator or cables. Some interfaces may display zero voltage even when voltages are present.***

## WARNING

### ***Electrical Generating Equipment***

***Incorrect operation and maintenance can result in severe personal injury or death. Make sure that only suitably trained and experienced service personnel perform electrical and/or mechanical service.***

**NOTICE**

Only authorized and qualified maintenance technicians, who are familiar with the equipment and its operation, should carry out maintenance.

**NOTICE**

Dependent upon the control system fitted, this unit may operate automatically and could start without warning.

**NOTICE**

Before carrying out any maintenance work, become familiar with [Section 1.3 on page 5](#), together with all the documentation supplied with the generator set.

**NOTICE**

Always disconnect a battery charger from its AC source before disconnecting the battery cables. Failure to do so can result in voltage spikes high enough to damage the DC control circuits of the generator set.

All maintenance tasks must be assessed for health and safety risks, the preventative measures identified must be actioned. Accompaniment is required for tasks where the presence of someone else will add significantly to the safety of the task.

Read, understand, and comply with all Caution and Warning notes in this section, those contained within [Chapter 1](#), and those contained within the documentation supplied with the generator set.

Ensure adequate lighting and staging (where required) are installed.

**NOTICE**

Before carrying out any maintenance work, lock the generator set out of service for safe working.

## 6.1 Locking the Generator Set Out of Service

Before any work is carried out for maintenance, etc., the generator set must be immobilized. Even if the generator set is put out of service by pressing the **Off** switch on the operator panel, the generator set cannot be considered safe to work on until the engine is properly immobilized, as detailed in the following procedures.

**NOTICE**

Refer also to the engine specific Operator Manual. This manual contains specific equipment instructions that may differ from the standard generator set.

### 6.1.1 Immobilizing for Safe Working

To immobilize the generator set:

1. Press the **Off** mode switch on the operator panel to shut down the generator set.
2. Press the **Emergency Stop button**. This prevents the generator set starting, regardless of the Start signal source and provides an additional safety step for immobilizing the generator set.

**NOTICE**

When the Emergency Stop button is pressed, the operator panel indicates a Shutdown condition. The red Shutdown status LED  illuminates and a message is displayed.

**NOTICE**

This condition is stored in the Fault History.

3. As an additional precaution, thoroughly ventilate the plant room before disconnecting any leads.
4. Isolate and lock off the supply to the heater, where fitted.
5. Isolate and lock off the supply to the battery charger, where fitted.
6. Isolate the fuel supply to the engine.
7. Using an insulated wrench, disconnect the negative (–) cable first on the starting batteries and control system batteries (if separate).
8. Fit warning notices at each of the above points to indicate Maintenance in Progress – Plant Immobilized for Safe Working.

## 6.2 Periodic Maintenance

The periodic maintenance procedures should be performed at whichever interval occurs first. At each scheduled maintenance interval, perform all previous maintenance checks that are due for scheduled maintenance.

The tabular data that follows gives the recommended service intervals for a generator set on Standby service. If the generator set will be subjected to Prime usage or extreme operating conditions, the service intervals should be reduced accordingly.

Some of the factors that can affect the maintenance schedule are:

- Use for continuous duty (prime power)
- Extremes in ambient temperature
- Exposure to elements
- Exposure to salt water
- Exposure to windblown dust or sand

Consult with an authorized distributor if the generator set will be subjected to any extreme operating conditions and determine if extra protection or a reduction in service intervals is needed. Use the running time meter to keep an accurate log of all service performed for warranty support. Perform all service at the time period indicated, or after the number of operating hours indicated, whichever comes first.

## 6.2.1 Periodic Maintenance Schedule

### 6.2.1.1 Air Intake Maintenance Schedule

TABLE 21. AIR INTAKE MAINTENANCE

MAINTENANCE ITEMS	Daily 8 Hours	Weekly 50 Hours	6 Months 250 Hours	12 Months 250 Hours	1500 Hours 12 Months	2000 Hours	2 Years 6000 Hours
Perform maintenance tasks as specified using Daily or Hourly periods – whichever occurs first							
Task	Operator Task		Service Technician Task				
Check air cleaner restriction indicator (where fitted): If the service indicator shows red, replace air cleaner elements and reset the air cleaner service indicator.	■						
Check air intake system for leaks: Visually inspect the air intake system for signs of wear or damage. Check audibly when the generator set is running. To replace, contact your authorized distributor.	■						
Clean air cleaner housing.				■			

### 6.2.1.2 Control Maintenance Schedule

TABLE 22. CONTROL MAINTENANCE

MAINTENANCE ITEMS	Daily 8 Hours	Weekly 50 Hours	6 Months 250 Hours	12 Months 500 Hours	1500 Hours 12 Months	2000 Hours	2 Years 6000 Hours
Perform maintenance tasks as specified using Daily or Hourly periods – whichever occurs first							
Task	Operator Task		Service Technician Task				
Check operation of Control Panel: Check display (the system will perform a control panel test on initial activation). To replace, contact your authorized distributor.	■						
Check operation of Emergency Stop Button: With the generator set running, press the Emergency Stop button. Check all systems, before resetting the fault.		■					

### 6.2.1.3 Cooling Maintenance Schedule

TABLE 23. COOLING MAINTENANCE

MAINTENANCE ITEMS	Daily 8 Hours	Weekly 50 Hours	6 Months 250 Hours	12 Months 250 Hours	1500 Hours 12 Months	2000 Hours	2 Years 6000 Hours
Perform maintenance tasks as specified using Daily or Hourly periods – whichever occurs first							
Task	Operator Task		Service Technician Task				
Check coolant level of radiator(s) (water jacket & LTA): If low, top up to coolant system specifications level, with Cummins recommended coolant mix.	■						
Check cooling fan blades: Visually inspect the fan blades through the guarding for signs of wear or damage. To replace, contact your authorized distributor.	■						
Check drive belt, condition and tension: Visually check belt for evidence of wear or slippage. To replace, contact your authorized distributor.	■						
Check coolant lines and radiator hoses for leaks, wear, and cracks: Visually check for leaks, worn or damages hoses. To replace, contact your authorized distributor.	■		■				
Check radiator air flow: Visually inspect the radiator through the guarding for blockage, build up of debris, signs of wear or damage. To clean or replace, contact your authorized distributor.	■						
Check anti-freeze and DCA concentration	■						
Clean radiator core.			■ <sup>1</sup>				
Re-grease bearings			■				
Check aftercooler core.						■	
Check water pump.						■	
Change coolant filter.			■				
Check coolant heater.			■				
Fan drive idler arm and fan belt tensioner check.					■		
Replace cooling system coolant.							■
■ <sup>1</sup> – Cleaning schedule may be reduced depending on operating conditions/environment. Contact your authorized distributor.							

TABLE 24. ENGINE MAINTENANCE

MAINTENANCE ITEMS	Daily 8 Hours	Weekly 50 Hours	6 Months 250 Hours	12 Months 250 Hours	1500 Hours 12 Months	2000 Hours	2 Years 6000 Hours
Perform maintenance tasks as specified using Daily or Hourly periods – whichever occurs first							
Task	Operator Task	Service Technician Task					
Check fuel lines and hoses: Visually check for leaks, worn or damages hoses. To replace, contact your authorized distributor.	■ <sup>1</sup>						
Check engine oil level: If low, top up to engine specifications level, with recommended oil.	■						
Drain water from fuel system primary filter/water separator: Drain one cup, or more, of fuel to remove water and sediment. See procedure in this chapter.	■						
Crankcase breather tube/collector. Check for condensed oil. Drain and dispose of in accordance with local legislation.	■						
Check charge alternator: Check visually and audibly when the generator set is running. To replace, contact your authorized distributor.	■						
Check engine oil make-up system: If low, top up to indicated level, with Cummins recommended oil.	■						
Check engine coolant heater: Check coolant heater has power and is running. To replace, contact your authorized distributor.	■						
Check all hardware (fittings, clamps, fasteners, etc.)			■				
Replace lubricating oil and filters.				■			
Check engine ground. Clean as necessary.				■			
Replace water separator element.			■	■			
Replace fuel system filters.			■	■			
Check engine mounts.			■				
Check pre-lube system (if fitted) for leaks and cracks					■		
Check starting motor.					■		
Check turbocharger.					■		
Engine oil heater check.					■		
Engine steam clean.					■		
Air compressor discharge lines check.					■		

MAINTENANCE ITEMS	Daily 8 Hours	Weekly 50 Hours	6 Months 250 Hours	12 Months 250 Hours	1500 Hours 12 Months	2000 Hours	2 Years 6000 Hours
Perform maintenance tasks as specified using Daily or Hourly periods – whichever occurs first							
<b>Task</b>	<b>Operator Task</b>		<b>Service Technician Task</b>				
Check air compressor unloader and valve assembly.							■
■ <sup>1</sup> – Check before starting and again with the generator set running.							

### 6.2.1.5 Exhaust Maintenance Schedule

TABLE 25. EXHAUST MAINTENANCE

MAINTENANCE ITEMS	Daily 8 Hours	Weekly 50 Hours	6 Months 250 Hours	12 Months 250 Hours	1500 Hours 12 Months	2000 Hours	2 Years 6000 Hours
Perform maintenance tasks as specified using Daily or Hourly periods – whichever occurs first							
<b>Task</b>	<b>Operator Task</b>		<b>Service Technician Task</b>				
Check all exhaust components, and hardware (fittings, clamps, fasteners, etc.): Visually inspect the exhaust system for signs of wear or damage. Check audibly when the generator set is running. To replace, contact your authorized distributor.	■						
Check exhaust condensation trap: Drain condensation into a suitable container. Dispose of fluids in accordance with local legislation.	■						

## 6.2.1.6 Generator Set Maintenance Schedule

TABLE 26. GENERATOR SET MAINTENANCE

MAINTENANCE ITEMS	Daily 8 Hours	Weekly 50 Hours	6 Months 250 Hours	12 Months 250 Hours	500 Hours	12 Months 1000 Hours	1500 Hours 12 Months	2000 Hours	2 Years 6000 Hours
Perform maintenance tasks as specified using Daily or Hourly periods – whichever occurs first									
Task	Operator Task	Service Technician Task							
Check fuel level in tank: If low, add fuel (A full tank reduces condensation.)	■								
Check bedframe/enclosure fluid containment (where fitted): Drain as necessary. Clean all contaminated areas. Dispose of fluids in accordance with local legislation.	■								
Inspect Engine/Alternator Flexible Rubber Coupling						■			
Check generator set enclosure: Visually check enclosure, walk around inspection of generator set. Make sure no inlets/outlets are covered/restricted, service access doors are operational and safety systems are in place and operational. To replace damaged parts, contact your authorized distributor.	■								
Check batteries: Check connections are secure and battery area is free from tools and other items.		■					■		
Check battery electrolyte level.				■					
Check electrical connections (battery, starter motor and alternator connections).				■			■		
Replace generator set fuel system filters - Single Fuel Filter					■				
Replace generator set fuel system filters - Duplex Fuel Filters					■				
Replace generator set fuel system filters - Double Fuel Filters				■					
Replace generator set fuel system filters - Triplex Fuel Filters				■					

**TABLE 27. PERIODIC MAINTENANCE SCHEDULE - 3000 HOURS TO SIX YEARS**

Maintenance Items	3000 Hours	2 Years or 3000 Hours	4000 Hours	6 months or 4000-4500 Hours	3 Years or 6000 Hours	6 Years or 12000 Hours
<b>Perform maintenance tasks as specified using Daily or Hourly periods – whichever occurs first</b>	<b>Service Technician Task</b>		<b>Operator Task</b>	<b>Service Technician Task</b>		
Check fuel injectors. Replace as necessary.	■					
Check aftercooler core. Clean as necessary.		■				
Check alternator bearing housings.						■
Check alternator winding condition.						■
Check alternator rotating diode assembly.						■
Replace cooling system coolant (commercial heavy duty).			■			
Replace cooling system coolant (ELC).						■
Replace alternator bearings.						■
Replace alternator NDE o-ring.						■
Add cooling system coolant extender (ELC).					■	
Clean and regrease alternator bearings.				■		

## 6.3 Maintenance Procedures - Daily or When Refueling

Monitor fluid levels, oil pressure, and coolant temperature frequently. During operation, be alert for mechanical problems that could create unsafe or hazardous conditions. The following sections cover several areas that should be frequently inspected for continued safe operation.

<b>NOTICE</b>
<b>Components that have guards against inadvertent touching must be visually inspected only. Do not remove the guards to do the inspection.</b>

### 6.3.1 General Information

Preventive maintenance begins with day-to-day awareness of the condition of the generator set. Before starting the generator set, check and look for:

- Oil and coolant levels
- Leaks
- Loose or damaged parts
- Worn or damaged belts

- Any change in engine noise or performance
- Generator set appearance

### 6.3.2 Engine Operation Report

The engine must be maintained in good mechanical condition if the operator is to obtain optimum satisfaction from its use. Running reports are necessary to enable programmed or emergency servicing to be carried out.

Comparison and intelligent interpretation of the running report, together with a practical follow-up action will eliminate most failures and emergency repairs.

Most engine problems give an early warning. Look and listen for changes in engine performance, sound, or appearance that can indicate service or repair is needed. Some engine changes to look for and report on are:

- Low lubricating oil pressure
- Low power
- Abnormal water or oil temperature
- Unusual engine noise
- Excessive use of coolant, fuel or lubricating oil
- Any coolant, fuel, or lubricating oil leaks
- Misfire
- Unexplained frequency fluctuation
- Significant vibration
- Excessive white and/or black exhaust smoke.

### 6.3.3 Generator Set Long Term Storage

Contact your authorized distributor if long term storage of the generator set is required. Long term storage procedures must be repeated every 12 months for Modular Common Rail Fuel System (MCRS) fuel equipped engines.

## 6.4 Generator Set Long Term Storage

Contact your authorized distributor if long term storage of the generator set is required. Long term storage procedures must be repeated every 12 months for Modular Common Rail Fuel System (MCRS) fuel equipped engines.

## 6.5 Cooling System

#### NOTICE

**Loss of coolant can allow the engine to overheat if it does not have the protection of a shutdown device. This can cause severe damage to the engine. Maintain coolant level for proper operation of high engine temperature shutdown system. If applicable, see the Model Specifications section for more information.**

## 6.5.1 Coolant Level - Check

### ⚠ WARNING

#### Scalding

*Do not remove the radiator cap from a hot engine; Failure to do so can result in personal injury from heated coolant spray or steam.*

*Wait until the temperature is below 50 °C (122 °F) before removing pressure cap. Remove filler cap slowly to release coolant system pressure.*

### ⚠ CAUTION

#### Skin Infection

*Avoid prolonged or repeated skin contact with antifreeze to prevent skin infections.*

*Comply with all local health and safety regulations/codes when handling or disposing of antifreeze.*

### ⚠ CAUTION

#### Cold coolant.

*Engine castings can be damaged.*

*Do not add cold coolant to a hot engine, allow the engine to cool to below 50 °C (122 °F) before adding coolant.*

### NOTICE

Never use a sealing additive to stop leaks in the coolant system. This can result in a blocked coolant system and inadequate coolant flow causing the engine to overheat.

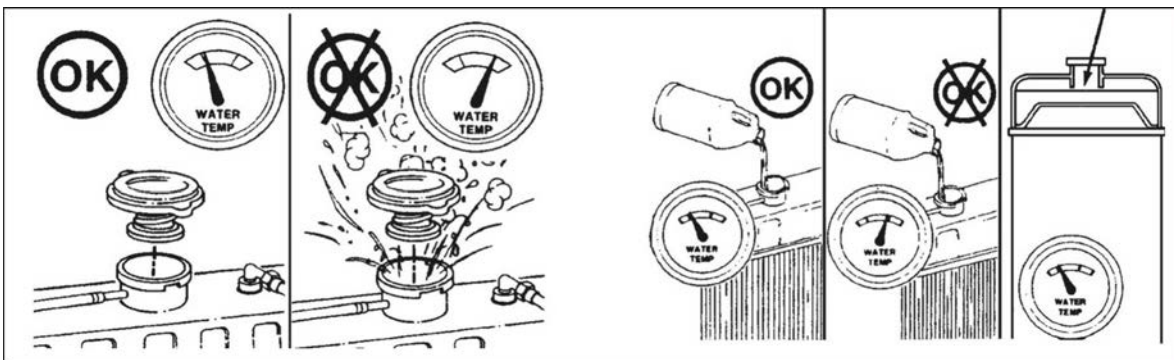

FIGURE 51. COOLANT LEVEL PROCEDURE

Coolant level must be checked daily. The standard coolant concentration is 50% Ethylene Glycol and water, this concentration must be maintained. Warranty claims for damage will be rejected if the incorrect mix of anti-freeze has been used. Consult your authorized distributor for the correct anti-freeze specifications and concentration for your operating conditions. The recommended antifreeze is Fleetguard® Compleat ES which is a low-silicate antifreeze, or its equivalent.

### NOTICE

On applications that use a coolant recovery system, check to make sure the coolant is at the appropriate level on the coolant recovery tank dependent on engine temperature.

Fill the cooling system with coolant to the bottom of the fill neck in the radiator or expansion tank, with the coolant temperature at 50 °C (122 °F) or lower.

### NOTICE

Some radiators have two fill necks, both of which must be filled. Refer to the generator set specific drawings supplied with the set.

## 6.5.2 Low Coolant Level Sender

The low coolant level sender is located near the top of the radiator, close to the radiator cap.

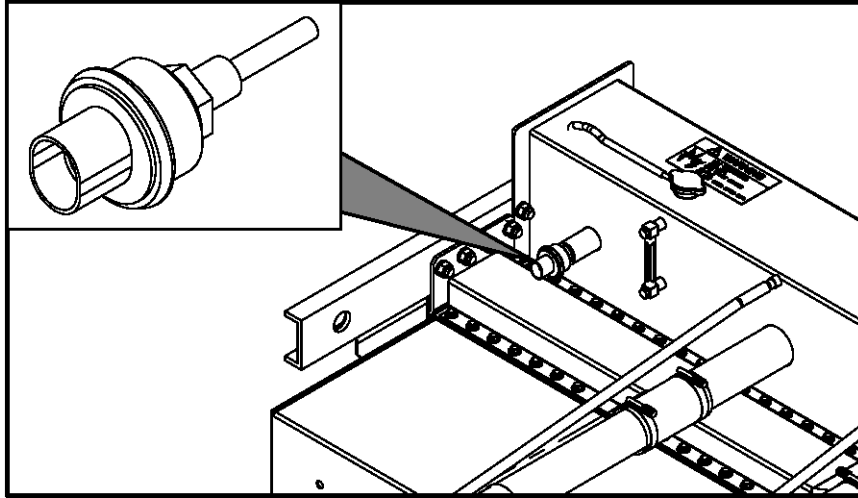

FIGURE 52. LOW COOLANT LEVEL SENDER

## 6.5.3 Cooling Fan - Inspection

### ⚠ WARNING

#### *Moving Parts*

*Moving parts can cause severe personal injury.*

*Use extreme caution around moving parts. All guards must be properly fastened to prevent unintended contact.*

### NOTICE

Never pull or pry on the fan, this can damage the fan blade(s) and cause fan failure.

A visual inspection of the cooling fan is required daily. Check for loose rivets or retaining bolts, for cracks, and bent or loose blades .

Do not operate the generator set with a damaged fan. Contact your authorized distributor for repair or replacement of a damaged fan.

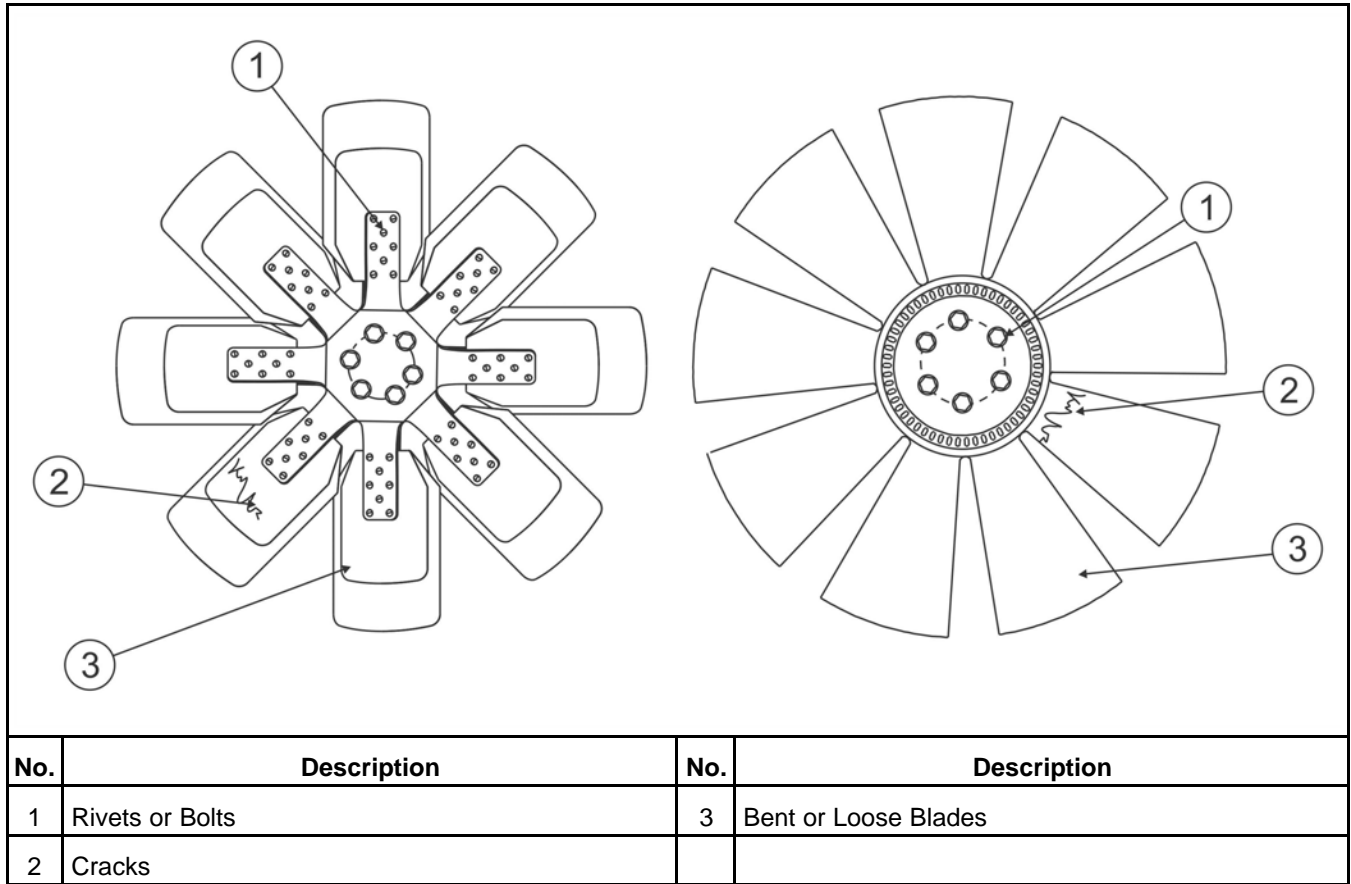

FIGURE 53. COOLING FAN INSPECTION CHECKPOINTS

### 6.5.4 Drive Belt - Inspection

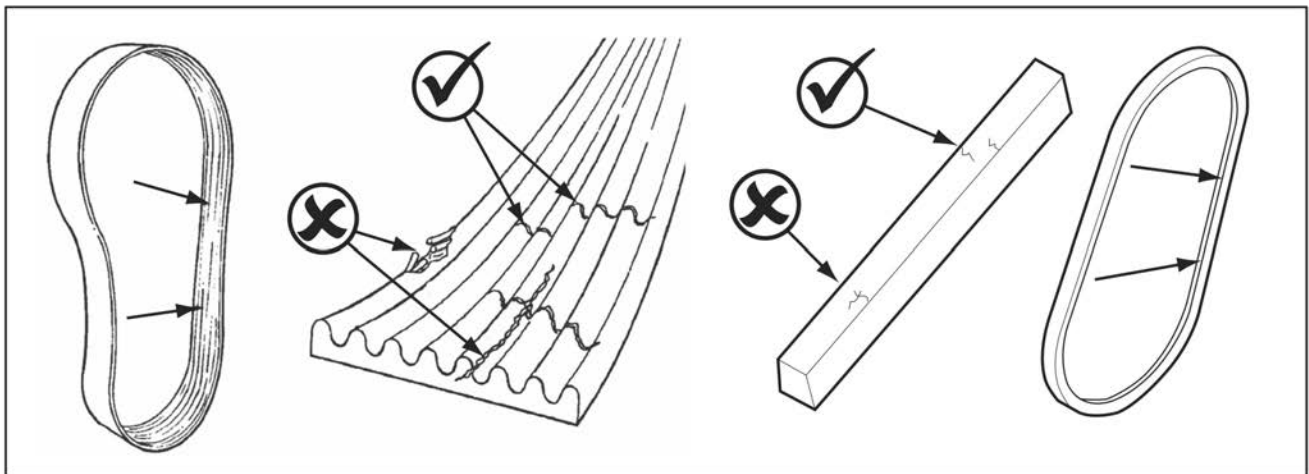

FIGURE 54. DRIVE BELT INSPECTION

Visually inspect the belt through the guarding.

Check for:

- Intersecting cracks. Small transverse (across the belt width) cracks are acceptable. Longitudinal (direction of belt length) cracks that intersect with transverse cracks are NOT acceptable.
- Frays or pieces of material missing.
- Glazed or cracked side walls.
- Uneven wear on sidewalls of belt.

**NOTICE**

**Do not mix old and new V-belts on the same drive.**

Contact your authorized distributor to have worn belts replaced.

Visually inspect sheaves through the guarding.

Check for:

- Damaged or worn grooves.
- Breaks on flanges of grooves.
- Frays or pieces of material missing.
- Glazed or cracked side walls.
- Uneven wear on sidewalls of belt.

**NOTICE**

**V-Belts should never ride in the bottom of the groove. Damaged or worn grooves should not be used.**

**NOTICE**

**Keep foreign materials away from sheaves and belts as this may cause belt slip.**

Contact your authorized distributor to have worn sheaves replaced.

## 6.5.5 Radiator Check

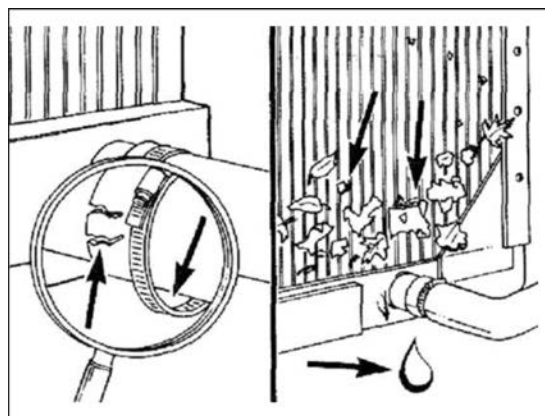

**FIGURE 55. RADIATOR CHECK**

Check for damaged hoses and loose and damaged hose clamps.

Inspect the exterior of the radiator (through the guarding) for obstructions. During the service life of a radiator a buildup of foreign matter can obstruct the flow of air through the radiator cores, reducing the cooling capability. To continue the efficiency of the radiator, the core will require cleaning.

Cleaning of the radiator core must only be undertaken by suitably trained and experienced service personnel.

## 6.5.6 Cooling System Maintenance

This section provides information on cleaning the radiator and updated information regarding bearings that has been provided by our supplier to enable efficient and prolonged life of the equipment.

### NOTICE

The following information regarding the correct choice and fitting of hose clamps has also been provided by our supplier to assist and guide the user.

### 6.5.6.1 Hose Clamp Installation

This section provides general installation guidelines for the correct positioning, orientation and torque figures required when fitting hose clamps. Recommended hose and clamp combinations are also included.

#### 6.5.6.1.1 Choosing the Right Hose Size

The recommended fit for hose to pipe is a 0.8mm interference fit, i.e. the inner diameter of the hose should be 0.5 mm smaller than the overall diameter of the pipe.

#### 6.5.6.1.2 Types of Hose Clamps

There are three main types of hose clamps:

- Constant Torque Clamps
- T-Clamps
- Worm Drive Clamps

##### 6.5.6.1.2.1 Constant Torque Clamps

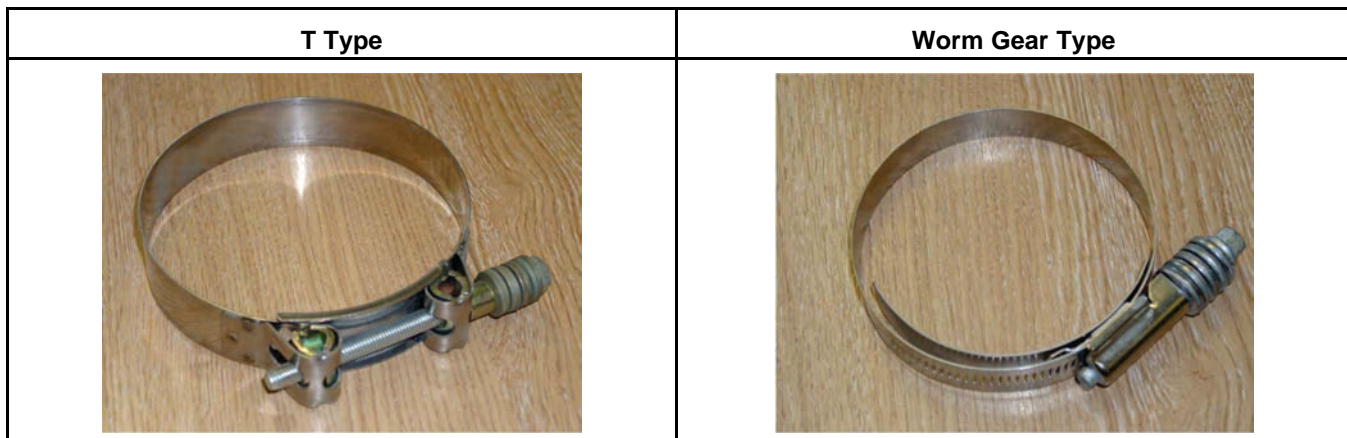

FIGURE 56. CONSTANT TORQUE CLAMPS

**TABLE 28. CONSTANT TORQUE CLAMP SPECIFICATIONS**

DIA. RANGE (mm)	BOLT SIZE	PIPE DIA. (mm)	HOSE TYPE	INSTALLATION TORQUE
25.4 – 44.4	3/8"	25.4	EPDM RUBBER	8 Nm
31.7 – 54.1	3/8"	38.1	APT THICK WALL	14 Nm
31.7 – 54.1	3/8"	38.1	EPDM RUBBER	14 Nm
31.7 – 54.1	3/8"	38.1	SILICONE NOMEX	14 Nm
57.1 – 79.5	3/8"	57.1	EPDM RUBBER	14 Nm
57.1 – 79.5	3/8"	57.1	APT THICK WALL	14 Nm
69.8 – 92.2	3/8"	76.2	APT THICK WALL	14 Nm
69.8 – 92.2	3/8"	76.2	SILICONE NOMEX	14 Nm
69.8 – 92.2	3/8"	76.2	EPDM RUBBER	14 Nm
82.5 – 104.9	3/8"	88.9	APT THICK WALL	14 Nm
95.2 – 117.65	3/8"	101.6	APT THICK WALL	14 Nm
95.2 – 117.65	3/8"	101.6	SILICONE NOMEX	14 Nm
95.2 – 117.65	3/8"	101.6	EPDM RUBBER	14 Nm
133.3 – 155.7	3/8"	127	APT THICK WALL	14 Nm

### 6.5.6.1.2.2 T-Clamps

**FIGURE 57. T-CLAMP**

DIA. RANGE (mm)	BOLT SIZE	PIPE DIA. (mm)	HOSE TYPE	INSTALLATION TORQUE
43 – 47	M6 X 50	38.1	SILICONE NOMEX	4 Nm
63 – 68	M7 X 60	57.1	EPDM RUBBER	4 Nm
68 – 73	M8 X 80	63.5	EPDM RUBBER	12 Nm
97 -104	M8 X 80	88.9	SILICONE NOMEX	12 Nm
121 – 130	M8 X 80	114.3	EPDM RUBBER	12 Nm
121 – 130	M8 X 80	114.3	SILICONE NOMEX	12 Nm

130 – 140	M8 X 80	127	EPDM RUBBER	12 Nm
130 – 140	M8 X 80	127	SILICONE NOMEX	12 Nm
162 - 174	M10 X 110	152.4	SILICONE NOMEX	30 Nm

### 6.5.6.1.2.3 Worm Drive Clamps



FIGURE 58. WORM DRIVE CLAMP

DIA. RANGE (mm)	INSTALLATION TORQUE	SOCKET REQUIRED	HOSE TYPE
8 - 16	3 Nm	7 mm	EPDM Rubber
12 - 20	3 Nm	7 mm	EPDM Rubber
16 - 25	4.5 Nm	7 mm	EPDM Rubber
25 - 40	4.5 Nm	7 mm	EPDM Rubber
20 - 32	4.5 Nm	7 mm	EPDM Rubber
32 - 50	4.5 Nm	7 mm	EPDM Rubber
40 - 60	4.5 Nm	7 mm	EPDM Rubber
50 - 70	4.5 Nm	7 mm	EPDM Rubber
60 - 80	4.5 Nm	7 mm	EPDM Rubber
70 - 90	4.5 Nm	7 mm	EPDM Rubber
80 - 100	4.5 Nm	7 mm	EPDM Rubber
90 - 110	4.5 Nm	7 mm	EPDM Rubber
100 - 120	4.5 Nm	7 mm	EPDM Rubber
120 - 140	4.5 Nm	7 mm	EPDM Rubber

## 6.5.6.2 Cleaning

### 6.5.6.2.1 General Cleaning

The Cleaning Of Radiator Cores Using Pressurized Water Equipment:

#### NOTICE

*In specific dust laden environments, this procedure should not be used as the initial cleaning operation; it should follow Cleaning - Dust Laden Environments.*

On enclosed generator sets with removable end panel(s), remove the end panel(s) to assist in the cleaning of the radiator.

Inspect the exterior of the radiator for obstructions. During the service life of a radiator, a build up of foreign matter can obstruct the flow of air through the radiator cores, reducing the cooling capability. To ensure the continued efficiency of the radiator, the core will require cleaning.

For thorough cleaning, pressure wash in the opposite direction to the airflow. A suitable proprietary degreasing additive (as recommended by the manufacturer of the pressure washer) should be applied via the pressure washer but this must not contain ammonia as it will corrode the core.

The recommended equipment for cleaning a radiator core is an industrial pressure washer, but it must be used in the correct manner as misuse can reduce the performance of the core. Protect the generator set from any over spray during this procedure.

To be effective, it is recommended that a hot water washer be used.

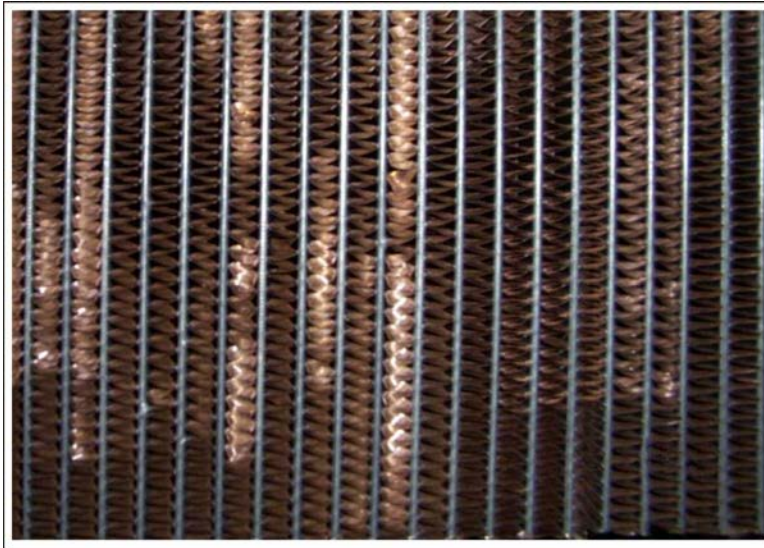

**FIGURE 59. FINS DAMAGED BY PRESSURE WASHING AT ACUTE ANGLES TO CORE FACE**

#### NOTICE

*With the pressures involved it is important that the distance between the core face and the nozzle is a minimum of 100 mm (3.93 inches); any closer and damage may occur.*

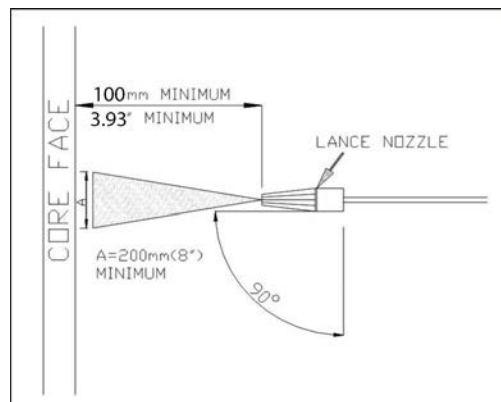

**FIGURE 60. PRESSURE WASHER NOZZLE POSITIONING**

**NOTICE**

**Most Industrial pressure washers work at pressures of around 1500 psi to 2000 psi (103 bar to 137.89 bar). It is very important that, when washing a core in this way, the lance must be kept at a right angle to the core**

**NOTICE**

***If your pressure washer works above 2000 psi, then the gap between the nozzle and the core face must be increased or fin damage will occur.***

**NOTICE**

***Always follow pressure washer Manufacturer's Health and Safety Guidelines.***

Replace the end panel(s) where necessary.

### 6.5.6.2.2 Dust Laden Environments

#### **Specific Instructions for the Cleaning of Radiator Cores Used in an Environment Subjected to Crushed Aggregate or Ceramic Dust Contamination**

On enclosed generator sets with removable end panel(s), remove the end panel(s) to assist in the cleaning of the radiator.

Inspect the exterior of the radiator for obstructions. During the service life of a radiator, a buildup of foreign matter can obstruct the flow of air through the radiator cores, reducing cooling capability. To maintain the efficiency of the radiator, the core will require cleaning.

Unless the radiator can be dismantled and the core treated in a professional caustic immersion cleaning system, the radiator should not be "wet" cleaned. This is because of the tendency of this type of contamination to coalesce and become extremely difficult to remove.

The correct procedure is to regularly blow through the entire core area with low pressure compressed air (against the direction of cooling airflow). It is very important to ensure that resultant debris blown from the core is subsequently removed and disposed of before engine start-up. An industrial vacuum cleaner will achieve this requirement. In most installations, it will be necessary to remove cowls and guarding.

To prevent damage to fins and resultant loss of cooling, it is important to ensure that the air gun used is maintained at right angles to the core face.

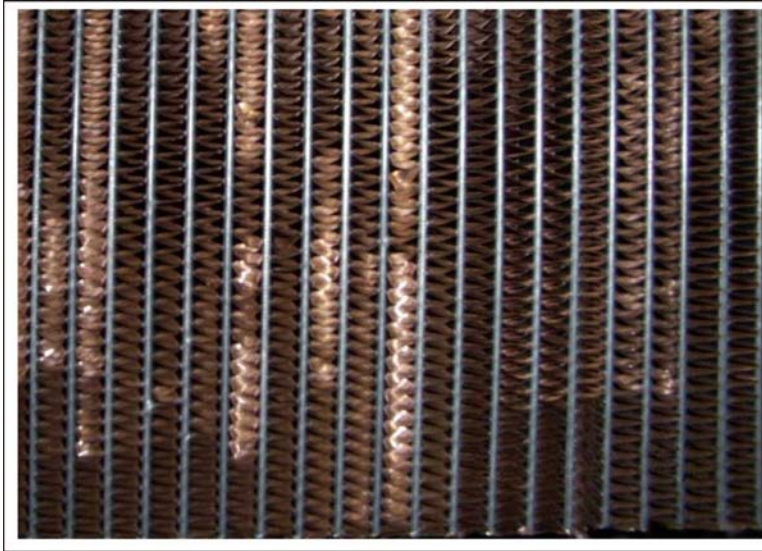

**FIGURE 61. FINS DAMAGED BY COMPRESSED AIR AT ACUTE ANGLES TO CORE FACE**

After this procedure has been effectively carried out with only the lightest of dust remaining, follow it immediately (if necessary) by cleaning the radiator cores using pressurized water equipment.

Replace the end panel(s) where necessary.

#### **NOTICE**

**It is vitally important that the core is thoroughly dried before start-up.**

### **6.5.6.3 Bearing Health Check**

The following information is relevant to both Interference Fit and Non-Interference Fit bearings.

Determine if there are any sounds emanating from the shaft/bearing assembly which may be indicative of failure, or imminent failure.

### **6.5.6.4 Bearing and Grease Change**

The fan drive and design has been changed to improve serviceability of the bearing set-up, both in terms of greasing and fitting.

## **6.6 Engine Oil**

### **6.6.1 Engine Oil Level Check**

#### **⚠ WARNING**

***Hot Pressurized Liquid***

***Contact with hot liquid can cause severe burns.***

***Crankcase pressure can blow out hot oil. Do not check the oil while the generator set is operating.***

**⚠ CAUTION****Hazardous Liquid**

*Prolonged or repeated skin contact can cause severe personal injury.*

*Avoid prolonged or repeated skin contact. Comply with all local health and safety regulations/codes during handling or disposal.*

**NOTICE**

**Do not operate the engine with the oil level below the low mark or above the high mark. Overfilling can cause foaming or aeration of the oil while operation below the low mark may cause loss of oil pressure.**

**NOTICE**

**Use high-quality multi-viscosity lubricating oil such as Cummins Premium Blue® or its equivalent. Consult your authorized distributor for the correct lubricating oil specifications for your operating conditions.**

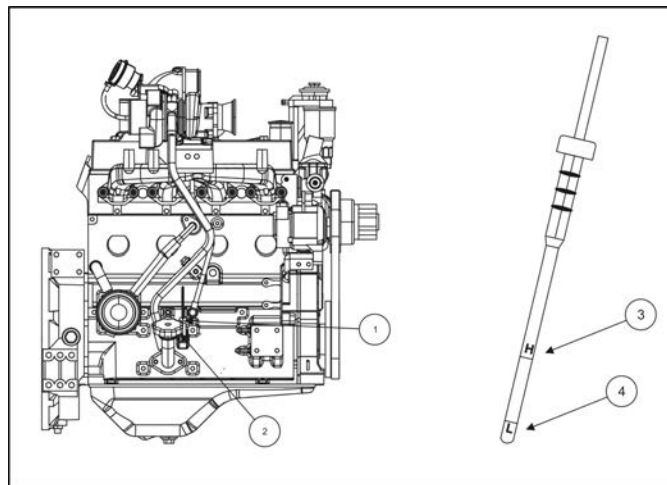

**FIGURE 62. OIL LEVEL CHECK**

The engine oil level must be checked daily before starting the engine, when the generator set is not running.

Never operate the engine with the oil level below the L (Low) mark (4), or above the H (High) mark (3).

1. Remove the dipstick (1) and with a lint free cloth wipe the dipstick clean.
2. Fully replace the dipstick.
3. Remove the dipstick and check the level of oil against the High and Low marks on the dipstick.
4. Top up to the High mark (3) if necessary with the correct grade of oil for your application.
  - a. Remove the filler cap (2).
  - b. Place a lint free cloth beneath or around the oil filler neck to minimize spillage.
  - c. Where possible use a funnel to help pour the new engine oil into the oil filler neck to the correct level.
  - d. Using the dipstick check the oil level, do not overfill the system. If more oil is needed then continue to fill with oil until the correct level is reached. If the level is too high then some of the oil will need to be drained of, refer to the engine operator and maintenance manual.

- e. Replace the dipstick and oil filler cap.
- f. Remove the lint free cloth, start the engine and allow to idle for five minutes, switch the engine off wait five minutes to allow the oil to drain back to the oil pan.
- g. Check the oil level. Repeat steps (1-5) if oil needs to be added.

Clean up any spillage and dispose of materials in accordance with local regulations.

## 6.6.2 Oil Sampling Valve

### WARNING

#### ***Moving Parts***

***Moving parts can cause severe personal injury.***

***Use extreme caution around moving parts. All guards must be properly fastened to prevent unintended contact.***

### WARNING

#### ***Toxic Hazard***

***Used engine oils have been identified by some state and federal agencies to cause cancer or reproductive toxicity.***

***Do not ingest, breathe the fumes, or contact used oil when checking or changing engine oil. Wear protective gloves and face guard.***

### WARNING

#### ***Hot Oil***

***Contact with hot oil can cause severe burns.***

***Avoid direct contact with hot oil. Allow the engine to cool down before carrying out any maintenance.***

### NOTICE

**The oil sampling intervals are dependent on usage, location and customers own requirements.**

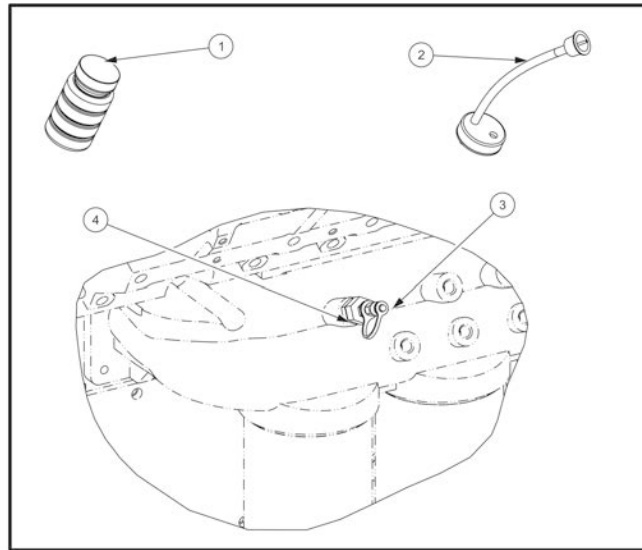

**FIGURE 63. TYPICAL OIL SAMPLING VALVE**

1. Remove the cap from the sample bottle (1) and attach the live sampling cap (2).
2. Remove the oil sampling drain valve cap (3) from the valve (4).
3. With the engine running at normal operating temperature, screw the live sampling cap (2) onto the drain valve (4), to allow the needle to fully depress the ball valve.
4. Fill the sample bottle as directed by the instructions supplied with the oil sampling kit/laboratory.
5. Remove the sample bottle (1) and replace the valve cap (3).
6. Remove the live sampling cap (2) from the sample bottle (1).
7. Replace the oil sampling bottle cap (1) and send for analysing.
8. Clean up any spillage and dispose of contaminated materials in accordance with local regulations.

## 6.7 Fuel System

### **⚠ WARNING**

#### ***Combustible Liquid***

***Diesel fuel is a fire and explosion hazard which can cause severe personal injury or death. Do not permit any open flame, or other igniter near the fuel system, or in areas sharing ventilation.***

### **⚠ WARNING**

#### ***Combustible Liquid***

***Mixing gasoline or alcohol with diesel fuel is an explosion hazard which can result in severe personal injury or death. Do not mix gasoline or alcohol with diesel fuels.***

### **NOTICE**

**Engine fuel actuators can operate at voltages up to 140 volts DC.**

**NOTICE**

**Due to the precise tolerances of diesel injection systems, it is extremely important that the fuel be kept clean and free of dirt or water. Dirt or water in the system can cause severe damage to both the injection pump and the injection nozzles.**

Use ASTM No. 2D fuel with a minimum Cetane number of 40. No. 2 diesel fuel gives the best economy and performance under most operating conditions. Fuels with Cetane numbers higher than 40 are often needed in high altitudes, or extremely low ambient temperatures, to prevent misfires and excessive smoke. Contact your authorized distributor for your operating conditions.

**NOTICE**

**A diesel fuel to BS 2869:2010+A1:2011 (Fuel oils for agricultural, domestic, and industrial engine and boilers. Specification), conforming to the requirements and test methods of that specification would be an acceptable alternative to ASTM No. 2D.**

## 6.7.1 Fuel Level

To avoid condensation problems, keep fuel supply tanks as full as possible by filling up each time the engine is used. Condensation (water) can cause clogging of the fuel filters as well as possible freezing problems. In addition, water mixing with the sulfur in the fuel forms acid which can corrode and damage engine parts.

**NOTICE**

**When filling the generator set fuel tank, make sure the fuel filler cap breather is not blocked. If the fuel cap breather is blocked it can cause air intake into the fuel tank to be erratic. Make sure the fuel filler cap is cleaned after each fill.**

## 6.7.2 Fuel/Water Separator Drain

Fuel/water separators provide protection for the engine fuel injection system, as water-free fuel supplies cannot be guaranteed.

Drain the water and sediment from the separator daily. The fuel filters can be inspected for collected water by checking the clear bowl at the bottom of each filter.

To drain the water:

1. Shut off the engine.
2. Place a suitable container under the fuel filter.
3. With the fuel supply valve closed, open the vent cap to break the airlock in the filter.
4. Turn the valve counterclockwise until the valve drops down about one inch (25 mm). Accumulated water will drain first. Drain the filter sump of water until clear fuel is visible.
5. When fuel begins to flow out of the drain, push the valve up and turn the valve clockwise to close the drain valve.
6. Before starting the engine, be sure to open the fuel supply valve.
7. If more than 2 oz (60 ml) is drained, refilling of the filter is required to prevent hard starting.

**NOTICE**

Do not over tighten the valve. Over tightening can damage the threads.

**NOTICE**

If more than 2 oz (60 ml) is drained, refilling of the filter is required to prevent hard starting.

The drained liquids must be disposed of in accordance with local environmental regulations.

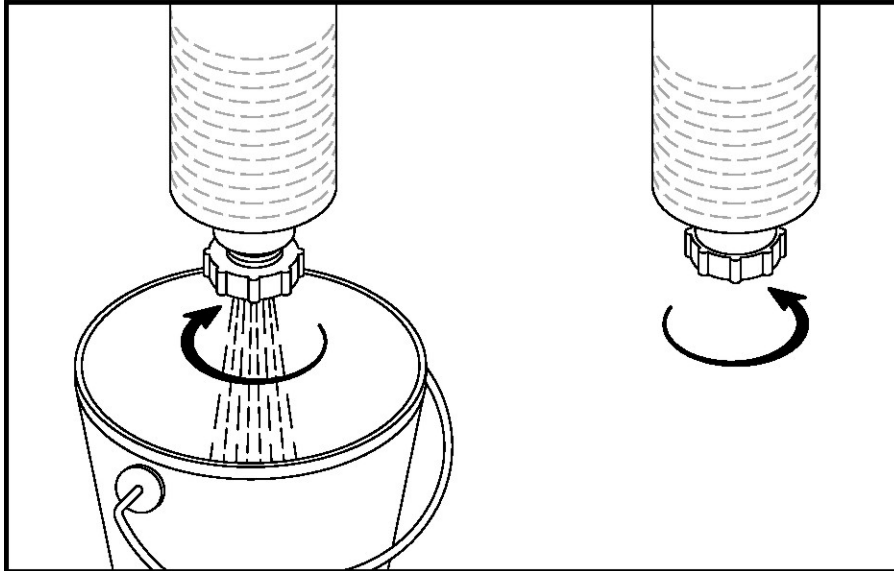

FIGURE 64. DRAINING THE FUEL/WATER SEPARATOR

## 6.8 Fuel Filter Maintenance

### 6.8.1 Fuel Filters - Drain

Refer to the engine specific manual for a more detailed procedure for draining the fuel filters.

Drain the water and sediment daily. The fuel filters can be inspected for collected water by checking the clear bowl at the bottom of each filter.

To drain the water:

1. Shut off the engine.
2. Place a suitable container under the fuel filter.
3. With the fuel supply valve closed, open the vent cap to break the airlock in the filter.
4. Open the drain valve. Accumulated water will drain first.
5. When fuel begins to flow out of the drain, close the drain valve.

The drained liquids must be disposed of in accordance with local environmental regulations.

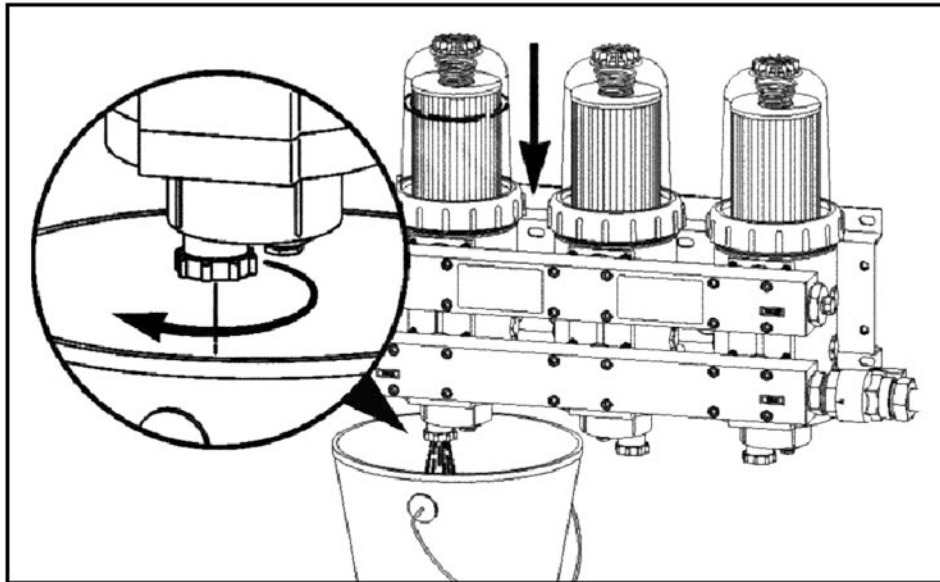

FIGURE 65. DRAINING THE FILTER/SEPARATORS

### 6.8.2 Fuel Filters - Element Removal

**⚠ WARNING**

*Combustible Liquid*  
 Diesel fuel is a fire and explosion hazard which can cause severe personal injury or death. Do not permit any open flame, or other igniter near the fuel system, or in areas sharing ventilation.

No.	Description	No.	Description
1	Vent Cap	3	Collar
2	Drain Valve	4	Clear Cover

FIGURE 66. FUEL FILTER REMOVAL - SINGLE TALL AND DUPLEX FUEL FILTERS

**NOTICE**

**The fuel must be drained from the filter head prior to removing the element. Do not allow fuel to drain onto the ground. Drained fuel must be collected and disposed of in accordance with local environmental regulations.**

1. Shut down the engine.
2. Close the fuel supply shutoff valve.
3. Place a suitable container under the filter to be replaced.
4. Use the collar/vent cap wrench to open the vent cap to break the air lock in the filter.
5. Open the drain valve, and allow the fuel level to drain to a point below the collar.
6. Close the drain valve.
7. Loosen the collar with the collar/vent cap wrench.
8. Remove the clear cover, filter spring, fuel filter element, and o-ring.
9. Remove the sealing grommet.
10. Discard the o-ring and grommet.

### 6.8.3 Fuel Filters - Element Removal

** WARNING*****Combustible Liquid***

***Diesel fuel is a fire and explosion hazard which can cause severe personal injury or death. Do not permit any open flame, or other igniter near the fuel system, or in areas sharing ventilation.***

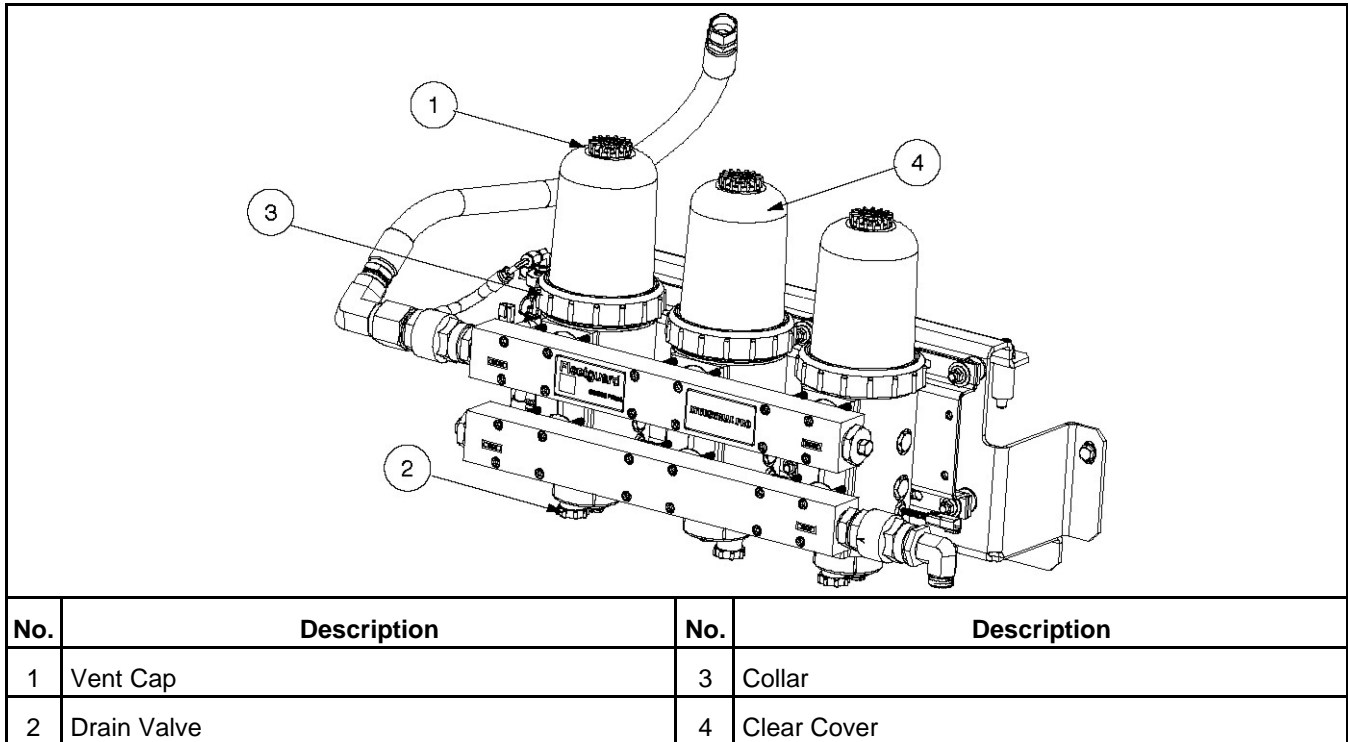

FIGURE 67. FUEL FILTER REMOVAL

**NOTICE**

The fuel must be drained from the filter head prior to removing the element. Do not allow fuel to drain onto the ground. Drained fuel must be collected and disposed of in accordance with local environmental regulations.

1. Shut down the engine.
2. Close the fuel supply shutoff valve.
3. Place a suitable container under the filter to be replaced.
4. Use the collar/vent cap wrench to open the vent cap to break the air lock in the filter.
5. Open the drain valve, and allow the fuel level to drain to a point below the collar.
6. Close the drain valve.
7. Loosen the collar with the collar/vent cap wrench.
8. Remove the clear cover, filter spring, fuel filter element, and o-ring.
9. Remove the sealing grommet.
10. Discard the o-ring and grommet.

## 6.8.4 Fuel Filter - Element Replacement

**⚠ WARNING**

**Combustible Liquid**  
**Diesel fuel is a fire and explosion hazard which can cause severe personal injury or death. Do not permit any open flame, or other igniter near the fuel system, or in areas sharing ventilation.**

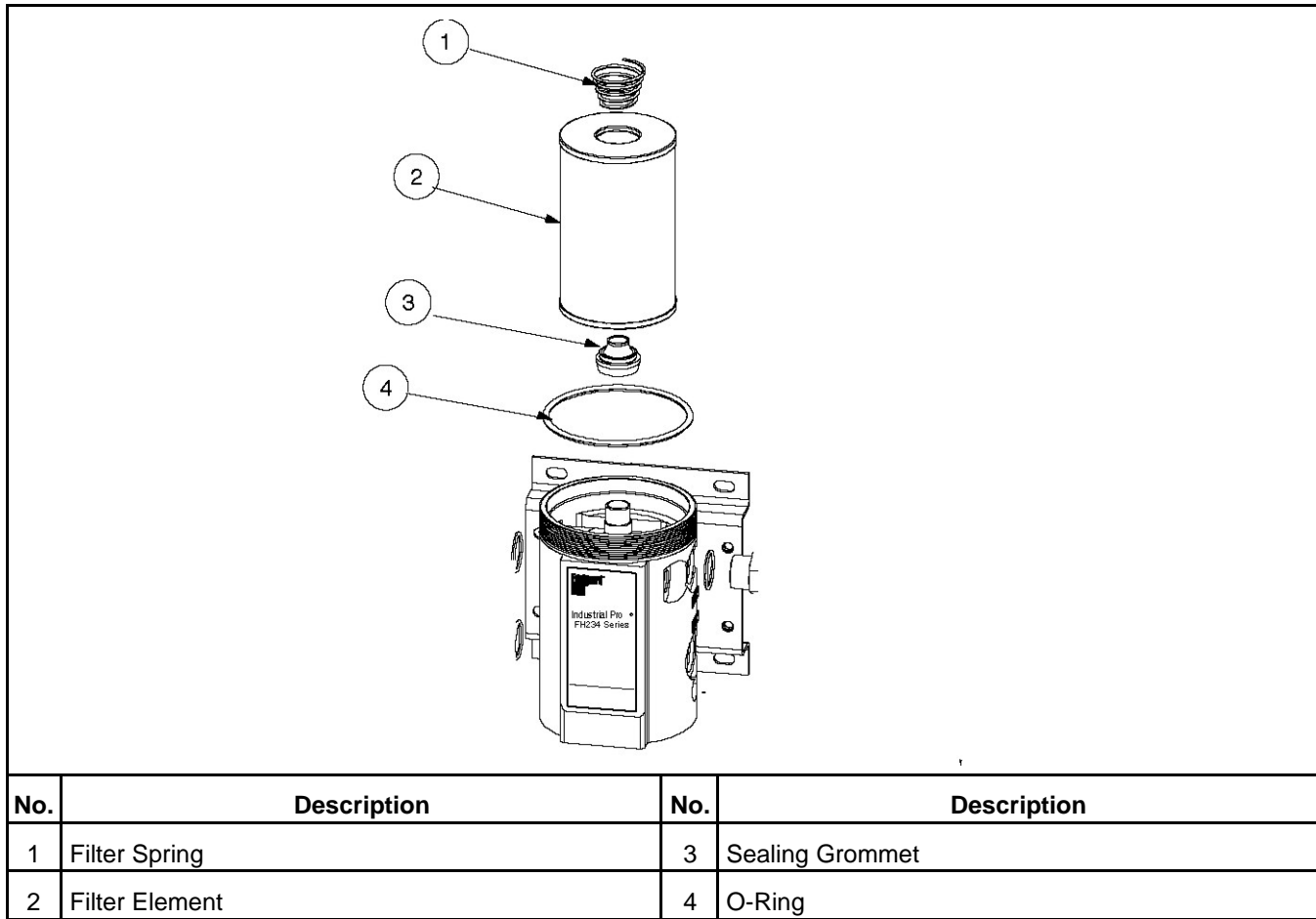

**FIGURE 68. FUEL FILTER ELEMENT REPLACEMENT**

**NOTICE**

**Fuel filter replacement includes the appropriate o-ring and sealing grommet. The o-ring and grommet must be replaced with the filter element to make sure of proper operation.**

1. Install a new o-ring, filter element (supplied with a sealing grommet inserted into the filter element), filter spring, and clear cover.
2. Install the vent cap and the collar onto the clear cover.
3. Hand tighten. Do not use tools to tighten the collar.

## 6.9 Hoses and Fuel Lines - Check

### ⚠ WARNING

#### *Moving Parts*

*Moving parts can cause severe personal injury.*

*Use extreme caution around moving parts. All guards must be properly fastened to prevent unintended contact.*

### ⚠ WARNING

#### *Hot Surfaces*

*Contact with the hot surfaces can cause severe burns.*

*Avoid contact with hot parts. Allow hot parts to completely cool.*

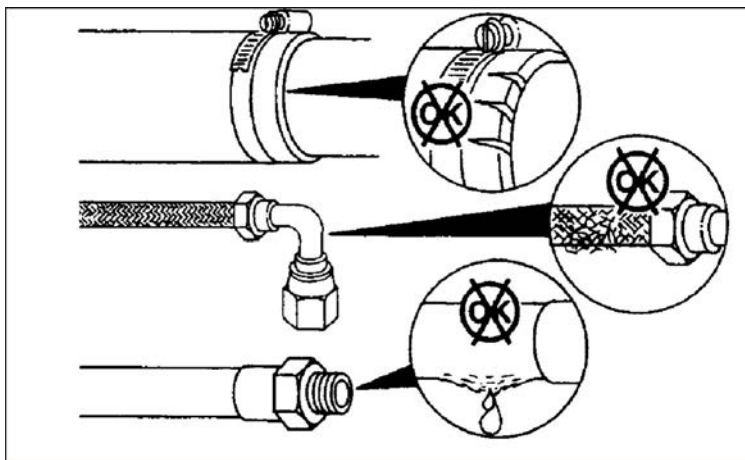

**FIGURE 69. HOSES AND FUEL LINE INSPECTION**

While the generator set is in operation, visually inspect the fuel lines, filters, and fittings for leaks. Check any flexible sections for cuts, cracks and abrasions and make sure they are not rubbing against anything that could cause breakage. If any leaks are detected, shut down the generator set (if possible). Contact your authorized distributor and have the leaks repaired immediately.

## 6.10 Air Intake System

The direct flow air cleaner consists of a primary filter and a secondary filter within the air cleaner housing. The air cleaner has been designed for a maximum restriction, at which point the filter elements should be changed. Refer to the Model Specifications section.

### 6.10.1 Air Cleaner Service Indicator

### ⚠ WARNING

#### *Moving Parts*

*Moving parts can cause severe personal injury.*

*Use extreme caution around moving parts. All guards must be properly fastened to prevent unintended contact.*

**⚠ WARNING**

**Hot Surfaces**  
**Contact with the hot surfaces can cause severe burns.**  
**Avoid contact with hot parts. Allow hot parts to completely cool.**

The air cleaner service indicator is located either on the air cleaner assembly or between the assembly and the inlet side of the turbocharger.

Check the air cleaner service indicator. If the gauge has crossed the red mark (1), replace the filter.

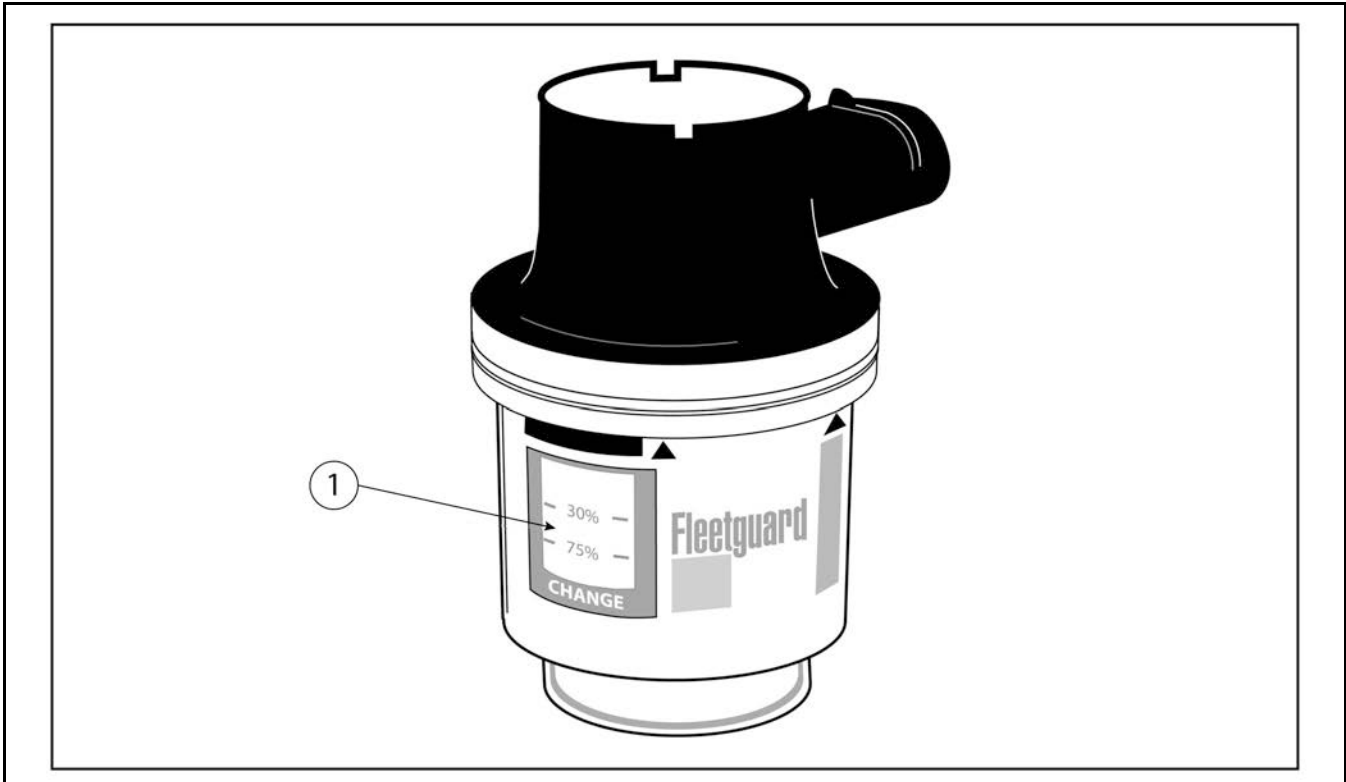

No.	Description
1	Red Mark

FIGURE 70. AIR CLEANER SERVICE INDICATOR

## 6.10.2 Normal Duty Air Cleaner

### 6.10.2.1 Normal Duty Air Cleaner Removal

Normal duty air cleaners combine centrifuge cleaning with element filtering before air enters the engine.

**⚠ CAUTION**

**Holes, loose-end seals, dented sealing surfaces, corrosion of pipes, and other forms of damage render the air cleaner inoperative and require immediate element replacement or engine damage can occur.**

**NOTICE**

**This air cleaner does not include a replaceable element.**

1. Loosen the hose clamp (2) securing the air cleaner (5) either to a hump hose (4) or an elbow (1).
2. Remove the air cleaner and the two air filter straps (3) from the mounting platform (6).
3. Remove the air filter straps from the air cleaner.
4. Dispose of the old air cleaner in accordance with local environmental agency requirements.

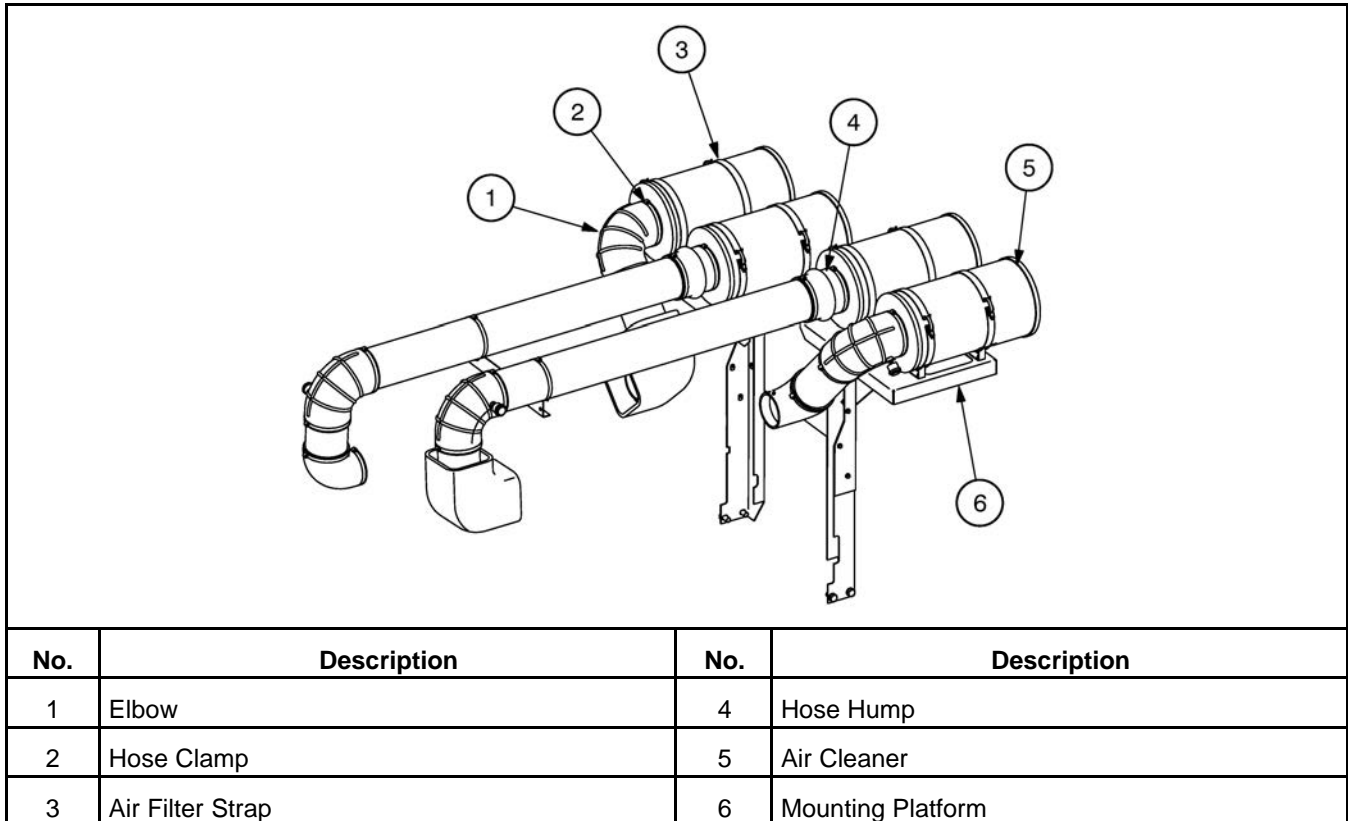

**FIGURE 71. NORMAL DUTY AIR CLEANER**

### 6.10.2.2 Normal Duty Air Cleaner Installation

Refer to [Figure 71](#).

1. Use the two air filter straps to install a new air cleaner on the mounting platform.
2. Reinstall the hose clamp to secure the air cleaner either to a hump hose or an elbow.

### 6.10.3 Heavy Duty Air Cleaner

#### 6.10.3.1 Heavy Duty Air Cleaner Element Removal

Heavy duty air cleaners combine centrifuge cleaning with element filtering before air enters the engine.

**NOTICE**

**Cummins Inc. does not recommend cleaning paper-type air cleaner elements. Elements that have been cleaned will clog, and airflow to the engine will be restricted.**

1. Before disassembly, wipe dirt from the cover and the upper portion of the air cleaner.
2. Remove the wing nut (4) from the end cap.
3. Remove the end cap (2).
4. Remove the air cleaner primary and inner safety elements (1 and 2).
5. Dispose of the dirty air cleaner elements in accordance with local environmental agency requirements.

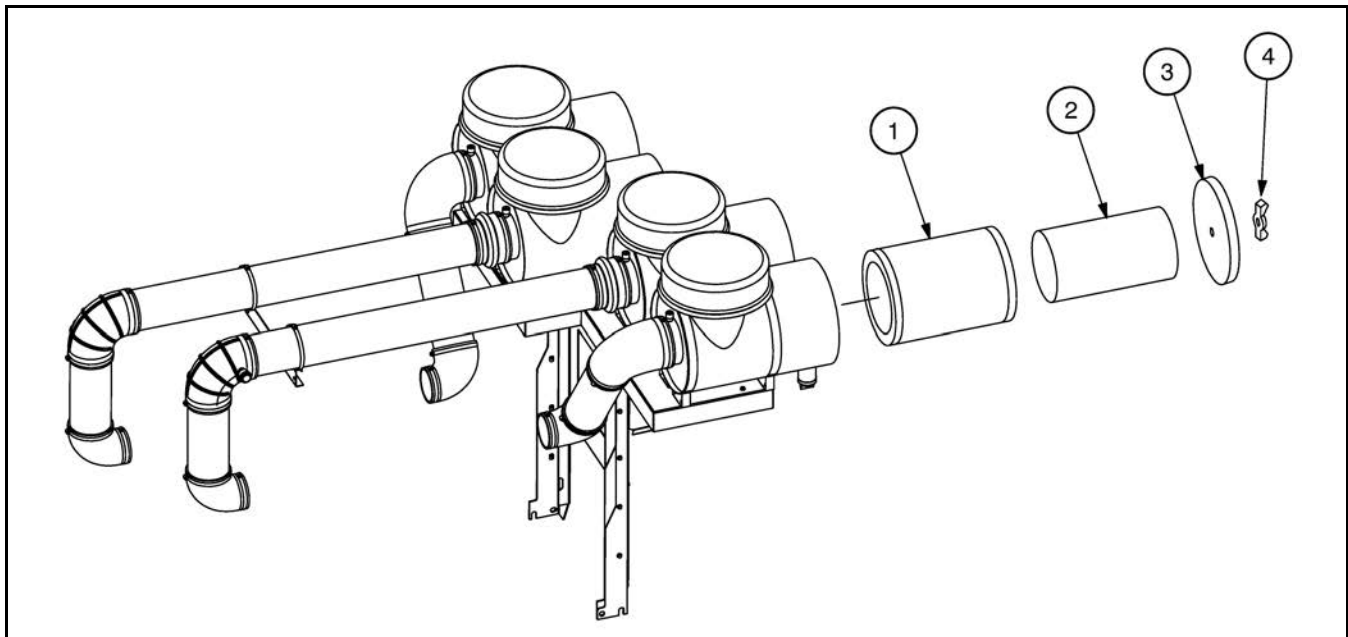

No.	Description	No.	Description
1	Air Cleaner Primary Element	3	End Cap
2	Air Cleaner Inner Safety Element	4	Wing Nut

**FIGURE 72. HEAVY DUTY AIR CLEANER**

### 6.10.3.2 Heavy Duty Air Cleaner Element Installation

Refer to [Figure 72](#).

1. Install the safety element (2) inside the air cleaner primary element (1).
2. Install the air cleaner elements inside the air cleaner canister.
3. Install the end cap (3) and secure it with the wing nut (4).

### 6.10.3.3 Heavy Duty Air Cleaner Maintenance

#### WARNING

##### ***Fall Hazard***

***Falls can result in severe personal injury or death.***

***Make sure that suitable equipment for performing tasks at height are used in accordance with local guidelines and legislation.***

There is a dust ejector valve (DEV) on the bottom of each filter pre-cleaner that should be checked periodically to make sure it is free of dust and dirt.

When there is a filter pre-cleaner, it includes a primary and secondary element that is checked periodically to make sure they are clean. Refer to the *Periodic Maintenance Schedule* table for additional information.

## 6.11 Exhaust System

#### WARNING

##### ***Hot Surfaces***

***Contact with the hot surfaces can cause severe burns.***

***Avoid contact with hot parts. Allow hot parts to completely cool.***

#### WARNING

##### ***Moving Parts***

***Moving parts can cause severe personal injury.***

***Use extreme caution around moving parts. All guards must be properly fastened to prevent unintended contact.***

#### WARNING

##### ***Toxic Gases***

***Substances in exhaust gases have been identified by some state and federal agencies to cause cancer or reproductive toxicity.***

***Do not breathe in or come into contact with exhaust gases.***

While the generator set is in operation, inspect the entire exhaust system visually and audibly including the exhaust manifold, muffler, and exhaust pipe without removing guarding and panels. Check for leaks at all connections, welds, gaskets and joints, and make sure that exhaust pipes are not heating surrounding areas excessively. If any leaks are detected, shut down the generator set (if possible). Contact your authorized distributor and have the leaks repaired immediately.

## 6.12 Generator Set Output - AC Electric System

Check the following while the generator set is operating:

- Frequency: The generator set frequency should be stable and the reading should be the same as the generator set nameplate rating (50 Hz / 1500 RPM or 60 Hz / 1800 RPM).
- AC Voltage: At no load, the line-to-line voltage, or voltages, should be the same as the generator set nameplate rating.

- AC Ammeter: At no load, the current readings should be zero. With a load applied, each line current should be similar.
- Panel Lamps: When the Operating Panel is first connected to the DC supply, the system runs a check, illuminating each of the indicator lamps in turn.

## 6.13 DC Electrical System

### ⚠ WARNING

**Ignition of explosive battery gases can cause severe personal injury. Do not use naked flames, smoke, or cause sparks while servicing batteries.**

1. Check the harness connections. If any harness connections are damaged, contact your service representative.

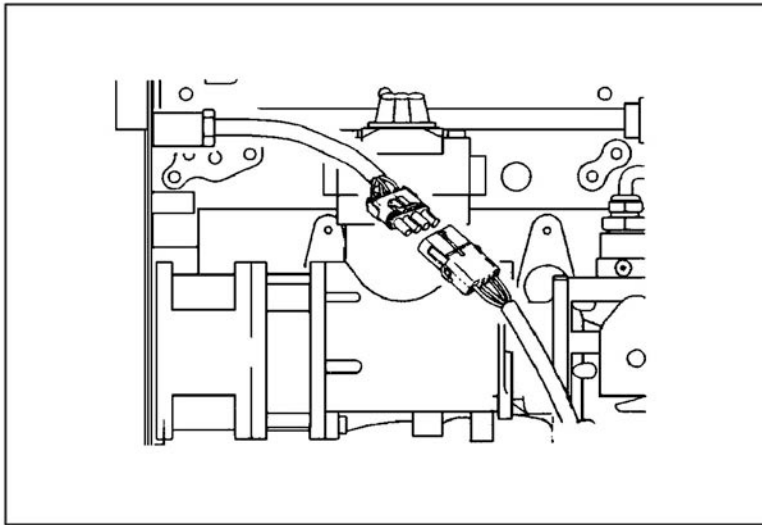

**FIGURE 73. HARNESS CONNECTIONS**

2. Check the terminals on the batteries for clean and tight connections. Loose or corroded connections create resistance, which can hinder starting. Clean and reconnect the battery cables if loose, using an insulated wrench. Always disconnect both ends of the negative battery cable. Reconnect one end of the cable to the negative battery terminal and the other end to ground. This will ensure that any arcing will be away from the battery and least likely to ignite explosive battery gases.
3. Check connections at the battery charging alternator.
4. Visually inspect the alternator belt to make sure it is not loose or cracked.

## 6.14 Batteries

Batteries are an essential part of any standby generator system. Roughly 90% of all generator failures are due to batteries.

It is important that batteries are stored, commissioned, and maintained as detailed here. Refer also to the Battery Manufacturer's instructions.

Always use correct handling techniques when moving or lifting batteries. Batteries can be heavy and may require more than one person to lift and a suitable trolley for transportation.

Batteries are usually supplied with the generator in 'dry-charged' form. In order to commission dry-charged lead-acid batteries, pre-mixed electrolyte of the correct type and specific gravity must be added to the cells of the battery.

Maintenance free batteries supplied with the generator need no maintenance for commissioning.

### 6.14.1 Storage

Batteries must be stored in a cool, dry, well-ventilated place, in the upright position, and with the vent caps securely in place.

Batteries must never be stacked on top of each other and must be protected from the floor by a wooden pallet or suitably thick cardboard sheet.

### 6.14.2 Safety Precautions

Servicing of batteries are to be performed or supervised by personnel knowledgeable of batteries and the required precautions. Keep unauthorized personnel away from batteries.

#### 6.14.2.1 General Precautions

#### WARNING

##### ***Combustible Gases***

***Ignition of battery gases is a fire and explosion hazard which can cause severe personal injury or death.***

***Laying tools or metal objects across the battery can cause arcing. Never lay tools or metal objects across the top of the battery.***

#### CAUTION

##### ***Electrical Shock***

***A battery presents a risk of electrical shock and high short circuit current which can cause minor or moderate injury.***

***Observe the following precautions when working on batteries.***

- Use proper PPE. Remove jewelry such as watches, rings, or other metal objects. Remove any conductive items from pockets. These items can fall into equipment and result in a short circuit, which can cause shock or burning. Refer to local standards for PPE details (in the U.S: see NFPA 70).
- Keep batteries upright to prevent spillage. Electrolyte is a dilute sulphuric acid that is harmful to the skin and eyes.
- Use tools with insulated handles to prevent the risk of electric shock.

### 6.14.2.2 Fire Hazard

#### NOTICE

During the charging of a battery, explosive gases are given off. Keep the battery area well ventilated and away from naked flames and sparks. Do not smoke.

- Before disconnecting a battery, isolate the utility powered battery charger (where fitted).
- To disconnect the battery, use an insulated wrench to disconnect the negative cable first.
- To connect the battery, use an insulated wrench to connect the negative cable last.

### 6.14.2.3 Fluid Hazard

#### ⚠ WARNING

##### *Toxic Hazard*

*Contact with electrolyte can cause severe personal injury.*

*Wear appropriate PPE when handling electrolyte: acid-proof protective apron, goggles, rubber gloves and boots. If electrolyte is splashed on the skin or in the eyes, flush the affected areas immediately with water and seek medical attention.*

#### ⚠ WARNING

##### *Hazardous Liquid*

*Uncontrolled chemical reactions can cause severe chemical burns or death.*

*Never add undiluted sulfuric acid to a battery.*

### 6.14.3 Battery Maintenance

#### ⚠ WARNING

##### *Combustible Gases*

*Ignition of battery gases is a fire and explosion hazard which can cause severe personal injury or death.*

*Do not smoke, or switch the trouble light ON or OFF near a battery. Touch a grounded metal surface first before touching batteries to discharge static electricity. Stop the generator set and disconnect the battery charger before disconnecting battery cables. Using an insulated wrench, disconnect the negative (-) cable first and reconnect it last.*

#### NOTICE

To prevent dangerous arcing, always disconnect the negative (-) ground cable from the battery using an insulated wrench before working on any parts of the electrical system or the engine. Before touching batteries, discharge static electricity from body by first touching a grounded metal surface.

#### NOTICE

Always disconnect a battery charger from its AC source before disconnecting the battery leads. Failure to do so can result in voltage spikes high enough to damage the DC control circuits of the generator set.

**NOTICE**

**Maintenance-free batteries are sealed and do not require the addition of electrolyte. Some manufacturers of maintenance-free batteries provide an 'eye' or some visible means of telling when the battery is discharged or approaching the end of its useful life.**

Batteries require attention at all times, even when not working. A battery will not last if it is neglected. Maintenance is carried out as follows:

1. Keep the battery and the battery area clean and dry. If fitted, make sure that the vent caps are securely screwed down, or pushed home.
2. To avoid contamination of the battery, clean it only when the vent plugs (if fitted) are in place.
3. Keep the battery terminals and connections free from corrosion by lightly coating them with petroleum jelly.
4. Secure the battery(s) to prevent movement and internal damage to plates.
5. Check the condition of the starting batteries. Refer to the Generator Set Maintenance table in [Section 6.2 on page 105](#) for the maintenance interval.

### 6.14.3.1 Cleaning Batteries

**⚠ WARNING*****Toxic Hazard***

***Contact with electrolyte can cause severe personal injury.***

***Wear appropriate PPE when handling electrolyte: acid-proof protective apron, goggles, rubber gloves and boots. If electrolyte is splashed on the skin or in the eyes, flush the affected areas immediately with water and seek medical attention.***

Prevent a buildup of dirt or corrosion by wiping the batteries with a damp cloth. Use a solution consisting of 0.11 kg (1/4 lb) of baking soda added to 0.96 liters (1 quart) of water to neutralize any possible acid. Be sure the vent plugs (if fitted) are tight to prevent any cleaning solution from entering the cells.

After cleaning, make sure the battery and surrounding areas are dry.

After making connections, coat the terminals with a light application of petroleum jelly to retard corrosion. Keep the battery terminals clean and tight. A loose connection can reduce battery standby time and cause battery fires.

### 6.14.3.2 Charging

When generator sets are used infrequently, batteries must be re-charged monthly to maintain a fully-charged condition.

**NOTICE**

**Never allow a battery to become completely flat (fully discharged), or to stand in a discharged condition, or damage will result.**

1. Do not put a filled battery into storage without first giving the battery a commissioning charge.
2. Batteries must be given a further charge every six months at the normal initial charge rate until the voltage ceases to rise.

### 6.14.3.3 Trickle/Boost Charging (Option)

The battery will automatically receive a trickle-charge from the battery charger (when switched ON) to prevent the battery from becoming discharged below its optimum charge level.

During trickle-charging, not all cells in the battery receive the same charge. Over a period of several months, this may affect battery performance. It is, therefore, good practice to give batteries a regular charge at their full rate to return all cells to full capacity. This is referred to as boost-charging, or equalize-charging.

If the charger is fitted with a **Boost Charge** switch, the **Boost** position should be selected at intervals detailed by the battery manufacturer (normally around every 6 months).

#### NOTICE

**Batteries should not be left on Boost Charge for extended periods as this results in excessive water consumption and gassing, and may impair battery performance.**

A boost charge not exceeding twice the bench charge rate may be used, providing that:

- The electrolyte temperature does not exceed 43 °C (109 °F).
- The battery volts do not reach 15 V (for a 12 V battery).

If either of these situations arises, reduce the charge rate to the normal bench rate. For tropical climates the temperature must not exceed 49 °C (120 °F).

#### NOTICE

**The charge period should be extended:**

- **To 8 hours if the battery has been in storage for three months or more at temperatures in excess of 30 °C (86 °F), or if humidity is above 80%.**
- **To 12 hours if the battery has been in storage for twelve months or more.**

At the end of the charging process, the electrolyte levels must be checked and restored if necessary by the addition of electrolyte of the correct SG. The vent caps must then be replaced.

#### NOTICE

**Any further topping-up of the electrolyte must be made using distilled or de-ionized water.**

## 6.14.4 Electrolyte - Specific Gravity and Temperature

Maintenance-free batteries are sealed and do not require the addition of electrolyte. Some manufacturers of maintenance-free batteries provide an 'eye' or other visible means of telling when the battery is discharged or approaching the end of its useful life.

### 6.14.4.1 Checking Electrolyte Level

#### NOTICE

**Never add tap or well water and never allow the battery electrolyte to drop below the top of the plates, otherwise damage will occur.**

**NOTICE**

**Do not add water in freezing weather unless the engine will run long enough (2 to 3 hours) to make sure that water and electrolyte are thoroughly mixed.**

Check the level of the electrolyte (acid and water solution) in the batteries at least every month or 100 hours of operation, whichever occurs first. Maintain the electrolyte to the levels indicated on the battery label. Add distilled water only and recharge. Replace the vent plugs once filling is completed.

If a cell level is low, check the case for leaks.

Keep the battery case clean and dry. An accumulation of moisture will lead to a more rapid discharge and battery failure.

#### 6.14.4.2 Checking Specific Gravity Using a Hydrometer

Use a hydrometer to check the specific gravity (SG) of the electrolyte in each battery cell.

Hold the hydrometer vertically and take the reading.

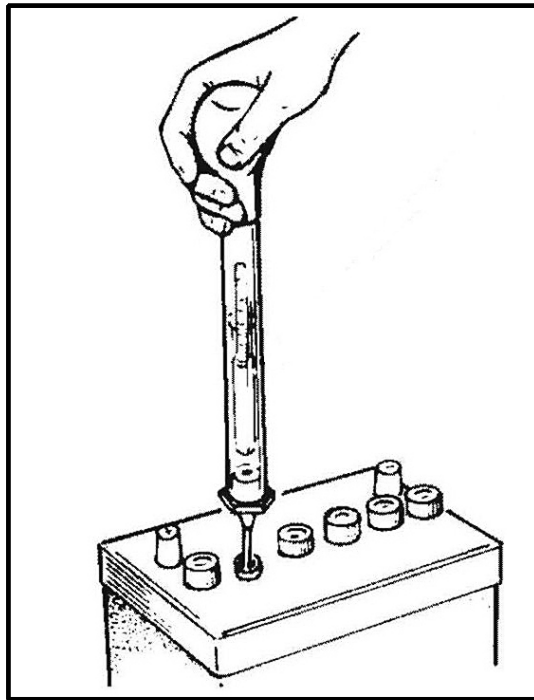

FIGURE 74. CHECKING SPECIFIC GRAVITY

#### 6.14.4.3 Checking Specific Gravity Using an Acid Refractometer

Follow the instructions included with the refractometer. Obtain a small drop of liquid and place it under the clear plastic cover to check the specific gravity (SG) of the electrolyte in each battery cell.

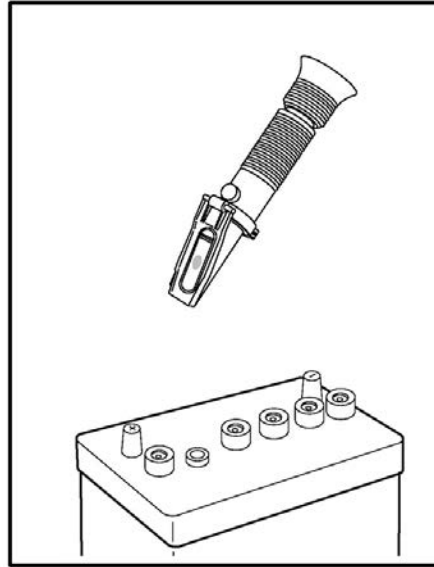

FIGURE 75. TYPICAL BATTERY ACID REFRACTOMETER

#### 6.14.4.4 Specific Gravity Values for Batteries

A fully charged battery will have a corrected specific gravity (SG) of 1.260 at 25 °C (77 °F). Hold the hydrometer vertically and take the reading. Charge the battery if the reading is below 1.215. The table below shows the specific gravity of electrolyte, corrected to 25 °C (77 °F).

TABLE 29. SPECIFIC GRAVITY

Temperature	For Filling New Cells	At End of Charge
Ambient temperature normally below 32 °C (90 °F)	1.270	1.270–1.290
Ambient temperature frequently above 32 °C (90 °F)	1.240	1.240–1.260
Maximum permissible temperature of electrolyte during charge	45 °C (113 °F)	45 °C (113 °F)

Correct the specific gravity reading for other temperatures by subtracting seven gravity points (0.007) for every 10 °C (18 °F) when the electrolyte temperature is above 27 °C (80 °F). Apply the correction formula as follows:

- For every 10 °C (18 °F) above 25 °C (77 °F), subtract 0.007 (7 points)
- For every 10 °C (18 °F) below 25 °C (77 °F), add 0.007 (7 points)

For example: if the specific gravity at 25 °C (77 °F) is 1.260, then the specific gravity at 15 °C (59 °F) is 1.267.

#### 6.14.5 Battery Replacement

##### **⚠ WARNING**

##### ***Combustible Liquid***

***Burning the battery may cause an explosion. Damage to the casing will release electrolytes which is harmful to the skin and eyes.***

***When disposing of a battery, do not mutilate or burn it. Comply with all local health and safety regulations/codes during handling or disposal.***

Always replace the starting battery with the same number and type (e.g., vented, lead acid, maintenance free) as listed in the specifications section of this document. Properly dispose of battery in accordance with local environment agency requirements.

Always use correct handling techniques to lift and move a battery.

## 6.14.6 Battery Type Specification

TABLE 30. BATTERY SPECIFICATION

Electrical System	
Starting Voltage	24 Volts DC
Battery Group Number	8D
Minimum Recommended Battery Capacity Cold Soak at -18 °C (0 °F)	2200 CCA

## 6.14.7 Battery Fault Finding

The following table shows some typical faults and their possible causes and remedies.

TABLE 31. FAULT FINDING

Symptom	Possible Fault	Remedy
Battery completely discharged	Poor battery terminal connection	Clean connections, replace and tighten.
	Charge alternator/ alternator connection fault	Contact your nearest Cummins distributor.
	Mains battery charger/ charger connections fault/ mains supply fault	Contact your nearest Cummins distributor.
	Blown fuse	Contact your nearest Cummins distributor.
	Battery fault	Contact your nearest Cummins distributor.
	Newly installed battery shipped dry	Fill with electrolyte and give commissioning charge.
Battery low charge	Poor battery connection	Clean connections, reconnect and tighten securely.
	Charge alternator/ alternator connection fault	Contact your nearest Cummins distributor.
	Mains battery charger/ charger connections fault	Contact your nearest Cummins distributor.
	Inequality in cell charge	Contact your nearest Cummins distributor.
	Battery fault	Contact your nearest Cummins distributor.

<b>Symptom</b>	<b>Possible Fault</b>	<b>Remedy</b>
Battery overcharged	Charge alternator fault	Contact your nearest Cummins distributor.
	Mains battery charge fault	Contact your nearest Cummins distributor.
	Low battery fluid level	Check the charger; it may not be shutting off when the charge is complete.
Battery terminals getting hot	Poor battery connection	Clean connections, reconnect and tighten securely.
		Contact your nearest Cummins distributor.

This page is intentionally blank.

# 7 Troubleshooting

---

Fault code information, together with warning and shutdown information, is provided in this section to assist in locating and identifying the possible causes of faults in the generator set system.

Refer also to the Operator's engine specific manual. The engine manual contains additional information regarding the running and care of the generator set as well as specific equipment instructions that may differ from the standard generator set.

## 7.1 Control System

The generator set control system continuously monitors engine sensors for abnormal conditions, such as low oil pressure and high coolant temperature. If any of these conditions occur, the control will light a yellow Warning lamp or a red Shutdown lamp and will display a message on the graphical display panel. In the event of an engine shutdown fault (red Shutdown LED), the control will stop the engine immediately.

## 7.2 Safety Considerations

### WARNING

#### *Hazardous Voltage*

*Contact with high voltages can cause severe electrical shock, burns, or death.*

*Make sure that only personnel who are trained and qualified to work on this equipment are allowed to operate the generator set and perform maintenance on it.*

### WARNING

#### *Automated Machinery*

*Accidental or remote starting of the generator set can cause severe personal injury or death.*

*Make sure that the generator set cannot be started accidentally or remotely before starting work on the generator.*

### WARNING

#### *Combustible Gases*

*Ignition of battery gases is a fire and explosion hazard which can cause severe personal injury or death.*

*Do not smoke, or switch the trouble light ON or OFF near a battery. Touch a grounded metal surface first before touching batteries to discharge static electricity. Stop the generator set and disconnect the battery charger before disconnecting battery cables. Using an insulated wrench, disconnect the negative (-) cable first and reconnect it last.*

### CAUTION

#### *Hazardous Voltage*

*Contact with high voltages can cause severe electrical shock, burns, or death.*

*Isolate all external electrical supplies prior to access of the control panel. Internal components have live exposed terminations even when the generator set is not running.*

**NOTICE**

***Isolator switch only:*** Do not open the output box while the generator set is running as the isolator switch will cause the generator set to shut down. Keep the output box covers in place during troubleshooting.

**NOTICE**

Always disconnect a battery charger from its AC source before disconnecting the battery cables. Failure to do so can result in voltage spikes high enough to damage the DC control circuits of the generator set.

**NOTICE**

Ventilate the battery area before working on or near the battery. Wear goggles. Stop the generator set and disconnect the battery charger before disconnecting the battery cables using an insulated wrench. Disconnect the negative (-) cable first and reconnect it last.

All maintenance tasks must be assessed for health and safety risks; the preventive measures identified must be performed. An additional person is required for any task where doing so significantly adds to the safety of the task.

The installation of a generator set can be designed for remote starting. When troubleshooting a generator set that is shut down, make sure that the generator set cannot be accidentally re-started. Refer to the Locking the Generator Set Out of Service section.

## 7.3 Fault Finding

**⚠ WARNING*****Electrical Generating Equipment***

***Incorrect operation and maintenance can result in severe personal injury or death.***

***Make sure that only suitably trained and experienced service personnel perform electrical and/or mechanical service.***

**NOTICE**

Review safety precautions listed within [Chapter 1 on page 1](#) of this manual together with the documentation supplied with the generator set.

Should a fault condition occur during operation, follow the procedures in the following tables to locate and correct the problem. For any symptom not listed, contact your authorized distributor for assistance.

Before starting any fault finding, ensure that the following basic checks are carried out:

- All switches and controls are in their correct positions
- Fuel system is connected and fuel is available
- The lubricating oil level is correct
- The coolant level is correct
- The radiator matrix is free from obstruction
- The battery charge condition is satisfactory and the connections are secure
- The generator set electrics and alternator connections are secure

- The panel connections are secure
- The protection circuits have been reset
- Blown fuses have been replaced
- Tripped contactors or circuit breakers have been reset

## 7.4 Status Indicators - PowerCommand 3.3

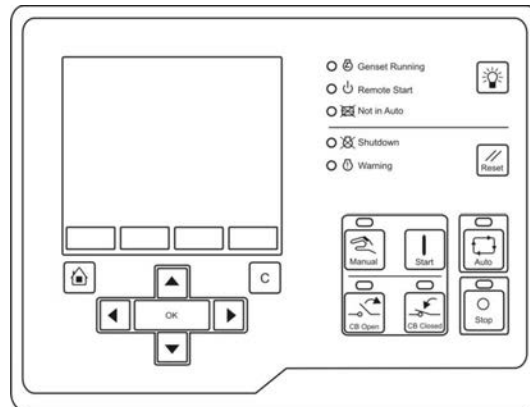

FIGURE 76. OPERATOR PANEL (HMI 320)

### 7.4.1 Not in Auto

This red lamp is lit when the control is not in Auto.

### 7.4.2 Remote Start

This green lamp indicates the control is receiving a **Remote Run** signal. The **Remote Run** signal has no effect unless the generator set is in Auto.

### 7.4.3 Warning

This amber lamp is lit whenever the control detects a Warning condition. This lamp is automatically shut off when the Warning condition no longer exists.

### 7.4.4 Shutdown Status

This red lamp is lit when the control detects a Shutdown condition. The generator set cannot be started when this lamp is on. After the condition has been corrected, the lamp can be reset by first pressing the **Stop** button and then the **Reset** button.

### 7.4.5 Generator Set Running Lamp

The green lamp is lit when the generator set is running at, or near, rated speed and voltage. This is not lit while the generator set is warming up or cooling down.

## 7.5 Fault/Status Codes - PowerCommand 3.3

### ⚠ WARNING

**Troubleshooting procedures.**  
**Troubleshooting procedures present hazards that can result in severe personal injury or death. Only trained and experienced service personnel with knowledge of fuels, electricity, and machinery hazards should perform service procedures.**

### ⚠ WARNING

**Accidental starting.**  
**Accidental starting of the generator set while working on it can cause severe personal injury or death.**  
**Prevent accidental starting by disconnecting the starting battery leads (negative [-] first).**

### NOTICE

**Gaps in the code numbers are for codes that do not apply to this generator set. Some of the codes listed are feature dependent and will not be displayed by this control.**

### 7.5.1 Fault Messages

A Fault message is an indicator of a Warning or Shutdown condition. It includes the fault type (Warning or Shutdown), fault number, and a short description. It also includes where the fault occurred if the generator set control did not detect the fault and is simply reporting the fault.

Active and acknowledged faults may be viewed in the Faults menu.

### 7.5.2 Fault Acknowledgement

Shutdown faults must be acknowledged after the fault has been corrected. If in Auto or Manual mode, the control must be set to Stop mode (Off). Faults are cleared from the control panel display by pressing the **Reset** button.

Faults are also acknowledged when in Auto mode and the remote start command is removed.

Faults are re-announced if they are detected again after being acknowledged.

### 7.5.3 Fault Codes - PowerCommand 3.3

TABLE 32. FAULT CODES

Code	Lamp	Displayed Message
111	Shutdown	Internal ECM Failure
115	Shutdown	Eng Crank Sensor Error
121	Warning	Engine Magnetic Crankshaft Speed or Position Lost One of Two Signals
122	Warning	Manifold 1 Press High
123	Warning	Manifold 1 Press Low
124	Warning	Manifold 1 Press High

<b>Code</b>	<b>Lamp</b>	<b>Displayed Message</b>
135	Warning	High Oil Rifle 1 Pressure
137	Warning	Oil Inlet Pressure Low Error
141	Warning	Low Oil Rifle 1 Pressure
142	Warning	Oil Overpressure
143	Warning	Low Oil Rifle Pressure
144	Warning	High Coolant 1 Temp
145	Warning	Low Coolant 1 Temp
146	Derate	Pre-High Engine Coolant Temperature
151	Shutdown	High Coolant Temp
153	Warning	High Intake Manf 1 Temp
154	Warning	Low Intake Manf 1 Temp
155	Shutdown	High Intake Manf 1 Temp
156	Warning	Intake Manifold Temp 2 OOR High
157	Warning	Intake Manifold Temp 2 OOR Low
158	Shutdown	Intake Manifold Temp 2 High
159	Warning	Intake Manifold Temp 3 OOR High
161	Warning	Intake Manifold Temp 3 OOR Low
162	Shutdown	Intake Manifold Temp 3 High
163	Warning	Intake Manifold Temp 4 OOR High
164	Warning	Intake Manifold Temp 4 OOR Low
165	Shutdown	Intake Manifold Temp 4 High
175	Shutdown	Throttle Control OOR High
176	Shutdown	Throttle Control OOR Low
177	Shutdown	Throttle Control Out of Adjustment
187	Warning	Sensor Supply 2 Low
189	Shutdown	HT Coolant Temperature Cause Unknown
195	Warning	High Coolant 1 Level
196	Warning	Low Coolant 1 Level
197	Warning	Low Coolant Level
212	Warning	High Oil 1 Temperature
213	Warning	Low Oil 1 Temperature
214	Shutdown	High Oil 1 Temp
219	Warning	Eng Oil Level Remote Reservoir: Least Severe Level
221	Warning	Air Pressure Sensor High

<b>Code</b>	<b>Lamp</b>	<b>Displayed Message</b>
222	Warning	Air Pressure Sensor Low
223	Warning	Oil Burn Valve Sol Low
224	Warning	Oil Burn Valve Sol High
227	Warning	Sensor Supply 2 Low
228	Shutdown	Low Coolant Pressure
229	Warning	HT Coolant Pressure Incorrect
231	Warning	High Coolant Pressure
232	Warning	Low Coolant Pressure
233	Warning	HT Coolant Pressure Moderate Low
234	Shutdown	Crankshaft Speed High
235	Shutdown	Low Coolant Level
236	Shutdown	Both Engine Speed Signals Lost
238	Warning	Sensor Supply 3 Low
239	Warning	Main Supply High
244	Warning	Red Stop Lamp Driver OOR Low
245	Warning	Fan Control Low
246	Warning	Exhaust Gas Temp Sensor 1 OOR High
247	Warning	Exhaust Gas Temp Sensor 1 OOR Low
248	Shutdown	Exhaust Gas Temp Sensor 1 High
253	Shutdown	Oil Level Low
254	Shutdown	FSO PWM High Control Error
255	Warning	FSO PWM Low Control Error
259	Warning	Engine Fuel Shutoff Valve Stuck Open
261	Warning	High Fuel Temperature
263	Warning	High Fuel 1 Temperature
265	Warning	Low Fuel 1 Temperature
266	Shutdown	High Fuel Temperature
271	Warning	Low Fuel Pump Press
272	Warning	High Fuel Pump Press
277	Warning	Fuel Control Valve Out of Adjustment
281	Warning	Cylinder Press Imbalance
284	Warning	Eng Speed/Position Sensor: Voltage Below Normal
285	Warning	CAN Mux PGN Rate Error
286	Warning	CAN Mux Calibration Error

<b>Code</b>	<b>Lamp</b>	<b>Displayed Message</b>
287	Warning	CAN Mux Accel Data Error
295	Warning	Key On Air Pressure Error
311	Warning	ACT1 FF Shorted HS TO LS Error
312	Warning	ACT5 Shorted HS TO LS Error
313	Warning	ACT3 RF Shorted HS TO LS Error
314	Warning	ACT6 Shorted HS TO LS Error
315	Warning	ACT2 FT Shorted HS TO LS_Error
319	Warning	RTC PWR Intr: Data Erratic Intermittent or Wrong
321	Warning	ACT4 RT Shorted HS TO LS Error
322	Warning	Inj 1 Solenoid Low Curr
323	Warning	Inj 5 Solenoid Low Curr
324	Warning	Inj 3 Solenoid Low Curr
325	Warning	Inj 6 Solenoid Low Curr
331	Warning	Inj 2 Solenoid Low Curr
332	Warning	Inj 4 Solenoid Low Curr
334	Warning	HT Coolant Temperature Incorrect
341	Warning	Engine Control Module Data Lost
342	Shutdown	Calibration Code Fail
343	Warning	ECM Hardware Failure
346	Warning	Powerdown Data Lost
351	Warning	Injector Supply Failure
352	Warning	Sensor Supply 1 Low
354	Warning	Manifold Absolute Pressure 1 High
355	Warning	Manifold Absolute Pressure 1 Low
359	Shutdown	Fail to Start
378	Warning	Elect Fuel Inj Cntrl Valve Ckt: Curr Below Normal
379	Warning	Elect Fuel Inj Cntrl Valve Ckt: Curr Above Normal
386	Warning	Sensor Supply 1 High
394	Warning	Eng Timing Actuator Driver: Curr Below Normal
395	Warning	Eng Timing Actuator Driver: Curr Above Normal
396	Warning	Fuel Cntl Valve Solenoid Driver 2 Sensor Ckt: OC
397	Warning	Fuel Cntl Valve Solenoid Driver 2 -
398	Warning	Eng Timing Actuator Driver 2 Circuit: OC
399	Warning	Eng Timing Actuator Driver 2: Grounded Ckt

<b>Code</b>	<b>Lamp</b>	<b>Displayed Message</b>
412	Event	J1708 Link Cannot Transmit
414	Event	J1708 Link Not Fast Enough
415	Shutdown	Low Oil Rifle Press
418	Warning	High H2O in Fuel
419	Warning	Intake Manifold Pres Bank Imbalance: Data Erratic
421	Warning	High Oil Temperature
422	Warning	Coolant Level Data Error
425	Warning	Oil Temperature Error
426	Event	SAE J1939 Datalink - Data Erratic, Intermittent, or Incorrect
427	Warning	CAN Data Link Degraded
428	Warning	Water in Fuel Indicator Sensor: Voltage Above Normal
429	Warning	Water in Fuel Indicator Sensor: Voltage Below Normal
433	Warning	Intake Manifold Press Sensor Ckt: Data Erratic
435	Warning	Oil Pressure Switch Error
441	Warning	Low Battery 1 Voltage
442	Warning	High Battery 1 Voltage
449	Shutdown	Inj Metering 1 Press High
451	Warning	Inj Metering 1 Press High
452	Warning	Inj Metering 1 Press Low
453	Warning	Gas Mass Flow High
454	Warning	Gas Mass Flow Low
458	Shutdown	Spark Timing B Error
459	Shutdown	Spark Timing A Error
461	Shutdown	Spark Reference B Error
462	Shutdown	Spark Reference A Error
471	Warning	Sump Oil Level Warning
477	Warning	Isolated Battery Voltage Low
478	Warning	Isolated Battery Voltage High
479	Warning	Exhaust Gas Temperature Data Incorrect
482	Warning	Fuel Press Low: Valid But Below Normal: Mod Severe
488	Derate	High Intake Manf 1 Temp
496	Warning	Eng Speed Sensor 2 Supply Volt: Root Cause Unknown
512	Warning	Throttle Position 1 Feedback OOR High
513	Warning	Throttle Position 1 Feedback OOR Low

<b>Code</b>	<b>Lamp</b>	<b>Displayed Message</b>
515	Warning	Sensor Supply 6 Circuit OOR High
516	Warning	Sensor Supply 6 Circuit OOR Low
546	Warning	Fuel Delivery Press High
547	Warning	Fuel Delivery Press Low
553	Warning	APC Pressure High
554	Warning	APC Pressure Error
555	Warning	Crankcase Pressure High: Above Normal
556	Shutdown	Crankcase Pressure High
557	Shutdown	Fuel Control Valve 2 OOR High
558	Warning	Fuel Control Valve 2 OOR Low
559	Warning	Inj Metering 1 Press Low
561	Shutdown	Heavy Knock Error 1 (A1)
562	Shutdown	Heavy Knock Error 2 (B1)
563	Shutdown	Heavy Knock Error 3 (A2)
564	Shutdown	Heavy Knock Error 4 (B2)
565	Shutdown	Heavy Knock Error 5 (A3)
566	Shutdown	Heavy Knock Error 6 (B3)
567	Shutdown	Heavy Knock Error 7 (A4)
568	Shutdown	Heavy Knock Error 8 (B4)
569	Shutdown	Heavy Knock Error 9 (A5)
571	Warning	Knock Cylinder 1 (A1) OOR Low
572	Warning	Knock Cylinder 2 (B1) OOR Low
573	Warning	Knock Cylinder 3 (A2) OOR Low
574	Warning	Knock Cylinder 4 (B2) OOR Low
575	Warning	Knock Cylinder 5 (A3) OOR Low
576	Warning	Knock Cylinder 6 (B3) OOR Low
577	Warning	Knock Cylinder 7 (A4) OOR Low
578	Warning	Knock Cylinder 8 (B4) OOR Low
579	Warning	Knock Cylinder 9 (A5) OOR Low
584	Warning	High Side DRV3 High Control Error
585	Warning	High Side DRV3 Low Control Error
591	Warning	Exhaust Backpressure High
592	Warning	Exhaust Backpressure Low
595	Warning	Turbo 1 Overspeed Warning Erro

<b>Code</b>	<b>Lamp</b>	<b>Displayed Message</b>
611	Warning	Engine Hot Shut Down
618	Warning	Turbo 1 Inlet Pressure High
619	Warning	Turbo 2 Inlet Pressure High
621	Event	Exhaust Gas Temperature Cylinder 1 Deviation Low: Below Normal
622	Event	Exhaust Gas Temperature Cylinder 3 Deviation Low: Below Normal
623	Event	Exhaust Gas Temperature Cylinder 5 Deviation Low: Below Normal
624	Event	Exhaust Gas Temperature Cylinder 7 Deviation Low: Below Normal
625	Event	Exhaust Gas Temperature Cylinder 9 Deviation Low: Below Normal
626	Event	Exhaust Gas Temperature Cylinder 11 Deviation Low: Below Normal
627	Event	Exhaust Gas Temperature Cylinder 13 Deviation Low: Below Normal
628	Event	Exhaust Gas Temperature Cylinder 15 Deviation Low: Below Normal
631	Event	Exhaust Gas Temperature Cylinder 2 Deviation Low: Below Normal
632	Event	Exhaust Gas Temperature Cylinder 4 Deviation Low: Below Normal
633	Event	Exhaust Gas Temperature Cylinder 6 Deviation Low: Below Normal
634	Event	Exhaust Gas Temperature Cylinder 8 Deviation Low: Below Normal
635	Event	Exhaust Gas Temperature Cylinder 10 Deviation Low: Below Normal
636	Event	Exhaust Gas Temperature Cylinder 12 Deviation Low: Below Normal
637	Event	Exhaust Gas Temperature Cylinder 14 Deviation Low: Below Normal
638	Event	Exhaust Gas Temperature Cylinder 16 Deviation Low: Below Normal
641	Shutdown	Exhaust Temperature 1 (A1) High
642	Shutdown	Exhaust Temperature 3 (A2) High
643	Shutdown	Exhaust Temperature 5 (A3) High
644	Shutdown	Exhaust Temperature 7 (A4) High
645	Shutdown	Exhaust Temperature 9 (A5) High
646	Shutdown	Exhaust Temperature 11 (A6) High
647	Shutdown	Exhaust Temperature 13 (A7) High
648	Shutdown	Exhaust Temperature 15 (A8) High
649	Event	Engine Oil Change Needed
651	Shutdown	Exhaust Temperature 17 (A9) High
652	Shutdown	Exhaust Temperature 2 (B1) High
653	Shutdown	Exhaust Temperature 4 (B2) High
654	Shutdown	Exhaust Temperature 6 (B3) High
655	Shutdown	Exhaust Temperature 8 (B4) High
656	Shutdown	Exhaust Temperature 10 (B5) High

<b>Code</b>	<b>Lamp</b>	<b>Displayed Message</b>
657	Shutdown	Exhaust Temperature 12 (B6) High
658	Shutdown	Exhaust Temperature 14 (B7) High
671	Warning	Exhaust Gas Temperature Cylinder 1 (A1) OOR Low
672	Warning	Exhaust Gas Temperature Cylinder 3 (A2) OOR Low
673	Warning	Exhaust Gas Temperature Cylinder 5 (A3) OOR Low
674	Warning	Exhaust Gas Temperature Cylinder 7 (A4) OOR Low
675	Warning	Exhaust Gas Temperature Cylinder 9 (A5) OOR Low
676	Warning	Exhaust Gas Temperature Cylinder 11 (A6) OOR Low
677	Warning	Exhaust Gas Temperature Cylinder 13 (A7) OOR Low
678	Warning	Exhaust Gas Temperature Cylinder 15 (A8) OOR Low
683	Warning	Turbo 2 Speed Moderate High
684	Warning	Turbo 2 Speed Moderate Low
685	Warning	Turbo 2 Speed Incorrect
686	Warning	Turbo 1 Speed Incorrect
687	Warning	Turbo 1 Speed Low
689	Warning	Crankshaft Speed Error
691	Warning	Turbocharger 1 Compressor Intake Temperature - Voltage above normal
692	Warning	Turbocharger 1 Compressor Intake Temperature - Voltage below normal
697	Warning	ECM Temperature High
698	Warning	ECM Temperature Low
721	Warning	Exhaust Gas Temperature 2 (B1) OOR Low
722	Warning	Exhaust Gas Temperature 4 (B2) OOR Low
723	Warning	Exhaust Gas Temperature 6 (B3) OOR Low
724	Warning	Exhaust Gas Temperature 8 (B4) OOR Low
725	Warning	Exhaust Gas Temperature 10 (B5) OOR Low
726	Warning	Exhaust Gas Temperature 12 (B6) OOR Low
727	Warning	Exhaust Gas Temperature 14 (B7) OOR Low
728	Warning	Exhaust Gas Temperature 16 (B8) OOR Low
731	Warning	Crankshaft Mech Misalign
736	Warning	Starter Air Pressure OOR Low
737	Warning	Starter Air Pressure OOR High
738	Warning	Starter Air Pressure Underpressure Error
741	Warning	Air Filter Restriction Pressure High Error
742	Warning	Air Filter Restriction Pressure Low Error

<b>Code</b>	<b>Lamp</b>	<b>Displayed Message</b>
751	Warning	Gas Mass Flow In Range Error
752	Warning	Exhaust Gas Oxygen In Range Error
757	Warning	All Persistent Data Lost Error
778	Warning	EPS Backup Lost Sync Error
781	Shutdown	CAN Data Link Failure
782	Warning	SAE J1939 Data Link 2 Engine Network No Data Received – Condition Exists
783	Shutdown	Intake Manf 1 Rate Error
831	Warning	Spark Plug 1 (A1) OOR Low
832	Warning	Spark Plug 2 (B1) OOR Low
833	Warning	Spark Plug 3 (A2) OOR Low
834	Warning	Spark Plug 4 (B2) OOR Low
835	Warning	Spark Plug 5 (A3) OOR Low
836	Warning	Spark Plug 6 (B3) OOR Low
837	Warning	Spark Plug 7 (A4) OOR Low
838	Warning	Spark Plug 8 (B4) OOR Low
839	Warning	Spark Plug 9 (A5) OOR Low
841	Warning	Spark Plug 10 (B5) OOR Low
842	Warning	Spark Plug 11 (A6) OOR Low
843	Warning	Spark Plug 12 (B6) OOR Low
844	Warning	Spark Plug 13 (A7) OOR Low
845	Warning	Spark Plug 14 (B7) OOR Low
846	Warning	Spark Plug 15 (A8) OOR Low
847	Warning	Spark Plug 16 (B8) OOR Low
848	Warning	Spark Plug 17 (A9) OOR Low
849	Warning	Spark Plug 18 (B9) OOR Low
891	Warning	Spark Plug 1 (A1) Root Cause Unknown
982	Warning	Spark Plug 2 (B1) Root Cause Unknown
893	Warning	Spark Plug 3 (A2) Root Cause Unknown
894	Warning	Spark Plug 4 (B2) Root Cause Unknown
895	Warning	Spark Plug 5 (A3) Root Cause Unknown
896	Warning	Spark Plug 6 (B3) Root Cause Unknown
897	Warning	Spark Plug 7 (A4) Root Cause Unknown
898	Warning	Spark Plug 8 (B4) Root Cause Unknown
899	Warning	Spark Plug 9 (A5) Root Cause Unknown

<b>Code</b>	<b>Lamp</b>	<b>Displayed Message</b>
911	Warning	Spark Plug 10 (B5) Root Cause Unknown
912	Warning	Spark Plug 11 (A6) Root Cause Unknown
913	Warning	Spark Plug 12 (B6) Root Cause Unknown
914	Warning	Spark Plug 13 (A7) Root Cause Unknown
915	Warning	Spark Plug 14 (B7) Root Cause Unknown
916	Warning	Spark Plug 15 (A8) Root Cause Unknown
917	Warning	Spark Plug 16 (B8) Root Cause Unknown
918	Warning	Spark Plug 17 (A9) Root Cause Unknown
919	Warning	Spark Plug 18 (B9) Root Cause Unknown
1117	Warning	Power Lost With Ignition On
1121	Warning	Fail To Disconnect
1122	Event	Rated To Idle Delay
1124	Warning	Delayed Shutdown
1128	Warning	Mixer Inlet Humidity Sensor: Volt Above Normal
1129	Warning	Mixer Inlet Humidity Sensor: Volt Below Normal
1131	Warning	Battle Short Active
1132	Warning	Controlled Shutdown
1139	Warning	UFD Injector 1 Error
1141	Warning	UFD Injector 2 Error
1142	Warning	UFD Injector 3 Error
1143	Warning	UFD Injector 4 Error
1144	Warning	UFD Injector 5 Error
1145	Warning	UFD Injector 6 Error
1213	Shutdown	Compressor Overboost Error
1219	Warning	Utility Breaker Tripped
1223	Warning	Utility Frequency
1224	Warning	Genset Overvoltage
1225	Warning	Genset Undervoltage
1226	Warning	Genset Frequency
1243	Derate	Engine Derated
1244	Shutdown	Engine Normal Shutdown
1245	Shutdown	Engine Shutdown Fault
1246	Warning	Unknown Engine Fault
1247	Shutdown	Unannounced Engine Shutdown

<b>Code</b>	<b>Lamp</b>	<b>Displayed Message</b>
1248	Warning	Engine Warning
1256	Warning	Ctrl Mod ID In State Error
1257	Shutdown	Ctrl Mod ID In State Fail
1274	Shutdown	Heavy Knock Error 10 (B5)
1275	Warning	Knock Cylinder 10 (B5) OOR Low
1276	Warning	Knock Cylinder 10 (B5) OOR High
1277	Warning	Knock Cylinder 11 (A6) OOR Low
1278	Warning	Knock Cylinder 11 (A6) OOR High
1279	Warning	Knock 12 (B6) High
1281	Shutdown	Heavy Knock Error 12 (B6)
1282	Warning	Knock Cylinder 12 (B6) OOR Low
1283	Warning	Knock Cylinder 12 (B6) OOR High
1284	Warning	Knock 13 (B7) High
1285	Shutdown	Continuous Light Knock Error 13 (A7)
1286	Shutdown	Heavy Knock Error 13 (A7)
1287	Warning	Knock Cylinder 13 (A7) OOR Low
1288	Warning	Knock Cylinder 13 (A7) OOR High
1289	Warning	Knock 14 (B7) High Warning
1291	Shutdown	Heavy Knock Error 14 (B7)
1292	Warning	Knock Cylinder 14 (B7) OOR Low
1293	Warning	Knock Cylinder 14 (B7) OOR High
1294	Warning	Knock 15 (A8) High Warning
1295	Shutdown	Continuous Light Knock Error 15 (A8)
1296	Shutdown	Heavy Knock Error 15 (A8)
1297	Warning	Knock Cylinder 15 (A8) OOR Low
1298	Warning	Knock Cylinder 15 (A8) OOR High
1299	Warning	Knock 16 (B8) High Warning
1311	Shutdown	Heavy Knock Error 16 (B8)
1312	Event	Configurable Input # 2
1317	Event	Configurable Input # 13
1318	Event	Configurable Input # 14
1322	Warning	kW Load Setpoint OOR High
1323	Warning	kW Load Setpoint OOR Low
1324	Warning	kVAR Load Setpoint OOR High

<b>Code</b>	<b>Lamp</b>	<b>Displayed Message</b>
1325	Warning	kVAR Load Setpoint OOR Low
1328	Warning	Genset Breaker Tripped
1336	Shutdown	Cooldown Complete
1338	Warning	Knock Cylinder 18 (B9) OOR Low
1339	Warning	Knock Cylinder 18 (B9) OOR High
1352	Warning	Knock 20 (B10) High Warning
1353	Shutdown	Continuous Light Knock Error 20 (B10)
1354	Shutdown	Heavy Knock Error 20 (B10)
1355	Warning	Knock Cylinder 20 (B10) OOR Low
1356	Warning	Knock Cylinder 20 (B10) OOR High
1357	Warning	Oil Remote Level Low
1362	Warning	Oil Filter Restriction Error
1363	Warning	Intake Manf 1 Press Low
1367	Event	High Prefilter Oil Press
1368	Event	Low Prefilter Oil Press
1369	Event	AUX Temperature 1 Sensor OOR High
1373	Event	Start Enable Device 1: Cause Unknown
1376	Warning	Camshaft Speed Error
1377	Event	Post Oil Filter Pressure OOR High
1378	Event	Post Oil Filter Pressure OOR Low
1383	Event	Intake Manifold 1 Pressure OOR High
1384	Event	Intake Manifold 1 Pressure OOR Low
1385	Event	Intake Manifold 2 Pressure OOR High
1386	Event	Intake Manifold 2 Pressure OOR Low
1411	Warning	High Out Freq Adjust Pot
1412	Warning	High Droop Adjust Pot
1416	Warning	Fail To Shutdown
1417	Warning	Power Down Failure
1418	Warning	High Gain Adjust Pot
1427	Warning	Overspeed Relay Error
1428	Warning	LOP Relay Error
1429	Warning	HET Relay Error
1431	Warning	Pre-LOP Relay Error
1432	Warning	Pre-HET Relay Error

<b>Code</b>	<b>Lamp</b>	<b>Displayed Message</b>
1433	Shutdown	Local Emergency Stop
1434	Shutdown	Remote Emergency Stop
1435	Warning	Low Coolant Temperature
1438	Shutdown	Fail To Crank
1439	Warning	Low Day Tank Fuel Switch
1441	Warning	Low Fuel Level
1442	Shutdown	Weak Battery
1443	Shutdown	Dead Battery
1444	Warning	Overload
1445	Shutdown	Short Circuit
1446	Shutdown	High AC Voltage
1447	Shutdown	Low AC Voltage
1448	Shutdown	Under Frequency
1449	Warning	Over Frequency
1451	Warning	Gen/Bus Voltages Out of Calibration
1452	Warning	Genset Breaker Fail To Close
1453	Warning	Genset Breaker Fail To Open
1454	Warning	Genset Breaker Position Contact
1455	Warning	Utility Breaker Position Contact
1456	Warning	Bus Out Of Synchronizer Range
1457	Warning	Fail To Synchronize
1458	Warning	Sync Phase Rotation Mismatch Overfrequency
1459	Shutdown	Reverse Power
1461	Shutdown	Loss of Field (Reverse kVAR)
1463	Event	Not In Auto
1464	Warning	Load Dump Fault
1465	Event	Ready To Load
1469	Shutdown	Speed/Hz Mismatch
1471	Warning	Over Current
1472	Shutdown	Over Current
1474	Shutdown	ECM Software Mismatch
1475	Warning	First Start Backup
1483	Event	Common Alarm
1517	Shutdown	Failed Module Shutdown

<b>Code</b>	<b>Lamp</b>	<b>Displayed Message</b>
1518	Warning	Failed Module Warning
1519	Warning	At Least One Module Has: Least Severe Fault
1521	Warning	Exhaust Gas Temperature 3 (A2) OOR High
1522	Warning	Exhaust Gas Temperature 5 (A3) OOR High
1523	Warning	Exhaust Gas Temperature 7 (A4) OOR High
1524	Warning	Exhaust Gas Temperature 9 (A5) OOR High
1525	Warning	Exhaust Gas Temperature 11 (A6) OOR High
1526	Warning	Exhaust Gas Temperature 13 (A7) OOR High
1527	Warning	Exhaust Gas Temperature 15 (A8) OOR High
1528	Warning	Exhaust Gas Temperature 17 (A9) OOR High
1529	Warning	Exhaust Gas Temperature 2 (B1) OOR High
1531	Warning	Exhaust Gas Temperature 6 (B3) OOR High
1532	Warning	Exhaust Gas Temperature 8 (B4) OOR High
1533	Warning	Exhaust Gas Temperature 10 (B5) OOR High
1534	Warning	Exhaust Gas Temperature 12 (B6) OOR High
1535	Warning	Exhaust Gas Temperature 14 (B7) OOR High
1536	Warning	Exhaust Gas Temperature 16 (B8) OOR High
1537	Warning	Exhaust Gas Temperature 18 (B9) OOR High
1540	Event	Common Warning
1541	Event	Common Shutdown
1545	Warning	EPS Backup Channel Lost
1546	Warning	EPS Main Channel Lost
1548	Warning	Inj 7 Solenoid Low Curr
1549	Warning	Inj 8 Solenoid Low Curr
1551	Warning	Inj 7 Solenoid Low Curr
1552	Warning	Inj 7 Solenoid Low Curr
1553	Warning	Inj 7 Solenoid Low Curr
1554	Warning	Inj 7 Solenoid Low Curr
1555	Warning	Inj 7 Solenoid Low Curr
1556	Warning	Inj 7 Solenoid Low Curr
1557	Warning	Inj 7 Solenoid Low Curr
1572	Shutdown	Continuous Light Knock Error 19 (A10)
1573	Event	Configurable Input #1
1574	Shutdown	Heavy Knock Error 19 (A10)

<b>Code</b>	<b>Lamp</b>	<b>Displayed Message</b>
1575	Warning	Knock Cylinder 19 (A10) OOR Low
1576	Warning	Knock Cylinder 19 (A10) OOR High
1579	Shutdown	Continuous Light Knock Error 12 (B6)
1581	Shutdown	Continuous Light Knock Error 14 (B7)
1582	Shutdown	Continuous Light Knock Error 16 (B8)
1583	Shutdown	Heavy Knock Error 16 (B8)
1584	Warning	Knock Cylinder 16 (B8) OOR Low
1585	Warning	Knock Cylinder 16 (B8) OOR High
1586	Warning	Knock 17 (A9) High Warning
1587	Shutdown	Continuous Light Knock Error 17 (A9)
1588	Shutdown	Heavy Knock Error 17 (A9)
1589	Warning	Knock Cylinder 17 (A9) OOR Low
1591	Warning	Knock Cylinder 17 (A9) OOR High
1592	Warning	Knock 18 (B9) High Warning
1593	Shutdown	Continuous Light Knock Error 18 (B9)
1594	Warning	Knock 19 (A10) High Warning
1596	Event	Aux Temperature 1 Sensor OOR Low
1597	Event	ECM Device/Component
1618	Warning	Exhaust Gas Temperature, Cylinder 1 (A1) OOR High
1619	Warning	Exhaust Gas Temperature, Cylinder 4 (B2) OOR High
1622	Warning	Inj 9 Solenoid Low Curr
1636	Warning	Intake Manifold Pressure 2 OOR High
1637	Warning	Intake Manifold Pressure 2 OOR Low
1664	Warning	Exhaust After Oxidation Catalyst Missing
1665	Warning	Aftertreatment Exhaust Gas Temp1: Voltage Below Normal
1666	Warning	Aftertreatment Exhaust Gas Temp1: Voltage Above Normal
1674	Warning	Aftertreatment Exhaust Gas Temp2: Voltage Below Normal
1675	Warning	Aftertreatment Exhaust Gas Temp2: Voltage Above Normal
1689	Warning	Real Time Clock Power
1691	Warning	After Oxidation Catalyst Efficiency: Below Normal
1695	Warning	Sensor Supply 5 High
1696	Warning	Sensor Supply 5 Low
1737	Shutdown	CAN Throttle Internal Failure Error
1738	Warning	CAN Throttle Internal Fault Error

<b>Code</b>	<b>Lamp</b>	<b>Displayed Message</b>
1739	Warning	Engine Throttle Control Condition Exists
1741	Warning	CAN Throttle High Temp Warning Error
1742	Warning	CAN Throttle Temperature Limiting Error
1743	Shutdown	Throttle Control 2 OOR High
1744	Shutdown	Throttle Control 2 OOR Low
1745	Shutdown	Throttle Control 2 Incorrect
1746	Shutdown	Throttle Control 2 Out of Adjustment
1747	Shutdown	Throttle Control 2 Bad Device
1748	Warning	Throttle Control 2 Root Unknown
1749	Warning	Throttle Control 2 Condition Exists
1751	Warning	Throttle Control 2 Warning High
1752	Warning	Throttle Control 2 Moderate High
1753	Warning	Fuel Shutoff 2 OOR High
1754	Warning	Fuel Temperature 2 OOR High
1755	Warning	Fuel Temperature 2 OOR Low
1756	Warning	Gas Flow 2 OOR High
1757	Warning	Gas Flow 2 OOR Low
1758	Warning	Gas Flow 2 Incorrect Data
1759	Shutdown	FCV 2 Positive Feedback Incorrect
1761	Shutdown	FCV Actuator Error
1765	Warning	Engine Gas Control Valve Inlet Pressure 2 OOR High
1766	Warning	Engine Gas Control Valve Inlet Pressure 2 OOR Low
1767	Warning	Engine Gas Control Valve Outlet Pressure 2 OOR High
1768	Warning	Engine Gas Control Valve Outlet Pressure 2 OOR Low
1769	Warning	Engine Emergency Shutdown Indication OOR High
1771	Warning	Engine Emergency Shutdown Indication OOR Low
1772	Warning	Engine Derate Request OOR High
1773	Warning	Engine Derate Request OOR Low
1774	Warning	Oil Priming Pump OOR High
1775	Warning	Oil Priming Pump OOR Low
1778	Warning	Engine Heater Control Driver High Error
1779	Warning	Engine Heater Control Driver Low Error
1781	Warning	Shutdown Request OOR High
1782	Warning	Shutdown Request OOR Low

<b>Code</b>	<b>Lamp</b>	<b>Displayed Message</b>
1783	Warning	Coolant Pump Control Driver High Error
1784	Warning	Coolant Pump Control Driver Low Error
1785	Warning	Oil Priming Pump Manual Override Input On
1786	Warning	Oil Priming Pump Stuck On Error
1787	Warning	Post Lube Oil Priming Error
1788	Warning	Maintenance Lube Oil Priming Error
1789	Shutdown	Pre-start Lube Oil Priming Error
1791	Shutdown	Failure To Meet Load Speed Error
1792	Warning	Idle when Circuit Breaker Closed
1794	Shutdown	Fire Detected
1795	Warning	Compressor Bypass Position High Error
1796	Warning	Compressor Bypass Position Low Error
1797	Warning	Compressor Bypass Control OOR High
1798	Warning	Compressor Bypass Control OOR Low
1799	Warning	Circuit Breaker Position Error Status
1811	Warning	High Side Driver 2 High Control Error (VPS)
1812	Warning	High Side Driver 2 Low Control Error (VPS)
1813	Warning	Valve Proving System Test Failed Warning Error
1814	Shutdown	Valve Proving System Test Failed Shutdown Error
1815	Warning	RLY14 High Control Error
1816	Warning	Oil Pre-heater Control OOR Low
1817	Warning	Oil Pre-heater Tripped Error
1818	Warning	Oil Pre-heater Not Warming Error
1819	Warning	Common AC Aux Circuit Breaker Tripped
1821	Shutdown	Minimum FSO Speed Error
1822	Shutdown	LT Coolant Level Low Shutdown Error
1823	Warning	LT Coolant Level Low Warning Error
1824	Warning	Idle Rated Trans Oil Temperature Low Error
1825	Warning	Dirty Oil Level Error
1826	Shutdown	ECM Software Incompatible
1827	Warning	Fuel Inlet Pressure High Error
1828	Warning	Fuel Inlet Pressure Low Error
1829	Shutdown	Vent Gas Valve Error
1831	Shutdown	Upstream FSO Valve Error

<b>Code</b>	<b>Lamp</b>	<b>Displayed Message</b>
1832	Shutdown	Downstream FSO Valve Error
1833	Warning	Engine Heater Trip Error
1834	Warning	Coolant Pump Trip Error
1835	Warning	Oil Priming Pump Tripped Error
1836	Shutdown	LCP (LT) Low Serious Error
1837	Shutdown	Permanent FS Cam Sync Lost Error
1838	Shutdown	Partial Engine Overload Shutdown Error
1839	Warning	Fuel Supply Pressure High Error
1841	Warning	Fuel Supply Pressure Low Error
1842	Warning	Radiator Fan Trip Error
1843	Warning	Crankcase Press High
1844	Warning	Crankcase Press Low
1845	Warning	H2O In Fuel Sens High
1846	Warning	H2O In Fuel Sens Low
1847	Shutdown	Eng Coolant Temp - Shutdown w/Cool
1852	Warning	Pre-High H2O In Fuel
1853	Event	Annunciator Input 1 Fault
1854	Event	Annunciator Input 2 Fault
1855	Event	Annunciator Input 3 Fault
1858	Warning	Exhaust After Inlet O2 OOR High
1859	Warning	Exhaust After Inlet O2 OOR Low
1861	Warning	Exhaust After Inlet O2 Incorrect
1862	Warning	Exhaust After Outlet O2 OOR High
1863	Warning	Exhaust After Outlet O2 OOR Low
1864	Warning	Exhaust After Outlet O2 Incorrect
1866	Warning	EGR DP Autozero Error
1879	Warning	Aftertreatment Particulate Filter Pressure OOR High
1881	Warning	Aftertreatment Particulate Filter Pressure OOR Low
1883	Warning	Aftertreatment Particulate Filter Pressure Incorrect
1885	Warning	Aftertreatment 1 Intake Nox Sensor: Voltage Below Normal
1891	Warning	Change Oil
1893	Warning	CAN EGR Valve Comm
1894	Warning	CAN VGT Comm Error
1895	Warning	EGA DL Mismatch Error

<b>Code</b>	<b>Lamp</b>	<b>Displayed Message</b>
1896	Warning	EGR DL Valve Stuck
1898	Warning	VGT Actuator Controller Out of Calibration
1899	Warning	Low EGR Dif Pressure
1911	Warning	Inj Metering 1 Press High
1912	Warning	Utility Loss Of Phase
1913	Warning	Genset Loss Of Phase
1914	Warning	Utility Phase Rotation
1915	Warning	Genset Phase Rotation
1916	Event	Sync Check OK
1917	Warning	Fuel Level High
1918	Shutdown	Fuel Level Low
1921	Warning	Aftertreatment Particulate Filter Pressure Above Normal
1922	Shutdown	Aftertreatment Particulate Filter Pressure Above Normal Critical
1933	Warning	High EGR Data Link Volt
1934	Warning	Low EGR Data Link Volt
1935	Warning	EGR DL Cmd Source Err
1938	Warning	ECU Power Output Voltage Below Normal
1942	Warning	THD AZ Error
1943	Event	CBR Density Derate Error ID
1944	Warning	HMI 113 Out Config Error
1961	Warning	High EGR DL EDU Temp
1962	Warning	VGT Actuator Driver Temperature Above Normal
1965	Warning	Aftertreatment Ext Gas Temperature 1 Data Above Normal
1966	Shutdown	Aftertreatment Ext Gas Temperature 1 Above Normal Most Severe
1968	Warning	Aftertreatment Ext Gas Temperature 2 Above Normal Severe
1969	Shutdown	Aftertreatment Ext Gas Temperature 2 Above Normal Most Severe
1974	Warning	Crankcase Press High
1978	Warning	Speed Bias OOR High
1979	Warning	Speed Bias OOR Low
1982	Shutdown	Catalyst Over Temperature Data Above Normal Most Severe
1983	Warning	Catalyst Over Temperature Data Above Normal Severe
1984	Warning	Int Man 2 Temperature Moderate High
1985	Warning	Int Man 3 Temperature Moderate High
1986	Warning	Int Man 4 Temperature Moderate High

<b>Code</b>	<b>Lamp</b>	<b>Displayed Message</b>
1992	Shutdown	Crankcase Sensor High
1993	Warning	Aftertreatment Particulate Filter Missing
1999	Warning	Maximum Parallel Time
2111	Warning	Coolant Inlet Temperature (LT) High Error
2112	Warning	Coolant Inlet Temperature (LT) Low Error
2113	Warning	CIT (LT) High Warning Error
2114	Shutdown	CIT (LT) High Serious Error
2115	Warning	LT Coolant Pressure High Error
2116	Warning	LT Coolant Pressure Low Error
2117	Warning	LCP (LT) Low Warning Error
2121	Warning	Exhaust Temperature 1 (A1) High Warning Error
2122	Warning	Exhaust Temperature 3 (A2) High Warning Error
2123	Warning	Exhaust Temperature 5 (A3) High Warning Error
2124	Warning	Exhaust Temperature 7 (A4) High Warning Error
2125	Warning	Exhaust Temperature 9 (A5) High Warning Error
2126	Warning	Exhaust Temperature 11 (A6) High Warning Error
2127	Warning	Exhaust Temperature 13 (A7) High Warning Error
2128	Warning	Exhaust Temperature 15 (A8) High Warning Error
2129	Warning	Exhaust Temperature 17 (A9) High Warning Error
2131	Warning	Exhaust Temperature 2 (B1) High Warning Error
2132	Warning	Exhaust Temperature 4 (B2) High Warning Error
2133	Warning	Exhaust Temperature 6 (B3) High Warning Error
2134	Warning	Exhaust Temperature 8 (B4) High Warning Error
2135	Warning	Exhaust Temperature 10 (B5) High Warning Error
2136	Warning	Exhaust Temperature 12 (B6) High Warning Error
2137	Warning	Exhaust Temperature 14 (B7) High Warning Error
2138	Warning	Exhaust Temperature 16 (B8) High Warning Error
2139	Warning	Exhaust Temperature 18 (B9) High Warning Error
2141	Warning	Start Air Pressure High Error
2142	Warning	Start Air Pressure Low Error
2143	Warning	SAP Overpressure Error
2144	Shutdown	Exhaust Temperature 16 (B8) High Serious Error
2145	Shutdown	Exhaust Temperature 18 (B9) High Serious Error
2146	Warning	EGT 17 (A9) OOR Low

<b>Code</b>	<b>Lamp</b>	<b>Displayed Message</b>
2147	Warning	EGT 18 (B9) OOR Low
2154	Warning	Oil Filter Outlet Pressure High Error
2155	Warning	Oil Filter Outlet Pressure Low Error
2157	Shutdown	Int Man 2 Temp Abnormal Rate
2158	Shutdown	Int Man 3 Tmp Abnormal Rate
2159	Shutdown	Int Man 4 Tmp Abnormal Rate
2184	Warning	Fuel Injection Control Valve Root Cause Unknown
2185	Warning	Sensor Supply 4 High
2186	Warning	Sensor Supply 4 Low
2188	Warning	Exhaust O2 OOR High
2191	Warning	ST Throttle Pressure Error Status
2192	Warning	Exhaust O2 OOR Low
2193	Warning	HT Coolant Level Moderate High
2198	Warning	VGT Actuator Driver Circuit Unknown Cause
2215	Warning	Fuel Pump Press Low
2217	Warning	RAM Image Word Error
2219	Warning	Exhaust O2 Moderate High
2221	Warning	Exhaust O2 Moderate Low
2231	Warning	Knock Cylinder 1 (A1) OOR High
2232	Warning	Knock Cylinder 2 (B1) OOR High
2233	Warning	Knock Cylinder 3 (A2) OOR High
2234	Warning	Knock Cylinder 4 (B2) OOR High
2235	Warning	Knock Cylinder 5 (A3) OOR High
2236	Warning	Knock Cylinder 6 (B3) OOR High
2237	Warning	Knock Cylinder 7 (A4) OOR High
2238	Warning	Knock Cylinder 8 (B4) OOR High
2239	Warning	Knock Cylinder 9 (A5) OOR High
2249	Warning	APC 2 Pressure Low
2261	Warning	Fuel Pump Press High
2262	Warning	Fuel Pump Press Low
2265	Warning	High Fuel Lift Pump Volt
2266	Warning	Low Fuel Lift Pump Volt
2272	Warning	EGR DL POS Sensor Error
2273	Warning	EGR Delta P OOR High Error

<b>Code</b>	<b>Lamp</b>	<b>Displayed Message</b>
2274	Warning	EGR Delta P OOR Low Error
2279	Warning	Knock 11 (A6) High Warning
2281	Shutdown	Knock 11 (A6) Moderate Warning
2282	Shutdown	Knock 11 (A6) Critical Warning
2288	Event	Turbo Charger 1 Speed Above Normal
2292	Warning	APC Flow high
2293	Warning	APC Flow Low
2298	Warning	Fuel Shutoff 2 OOR Low
2311	Warning	EFI Control Valve Fail
2313	Warning	Fuel Control Valve Error
2315	Warning	Red Lamp OOR High
2316	Warning	Amber Lamp OOR High
2317	Warning	Amber Lamp OOR Low
2328	Event	Utility Available
2331	Warning	Utility Undervoltage
2332	Event	Utility Connected
2333	Event	Genset Connected
2335	Shutdown	AC Voltage Sensing Lost (Excitation Fault)
2336	Shutdown	Bad Checksum
2342	Warning	Too Long In Idle
2343	Event	Fuel Filter Pressure High Above Normal
2346	Event	CBR TFC Derate Error ID
2349	Warning	EGR DL Motor Open Error
2351	Warning	EGR DL Motor Short Error
2353	Warning	EGR Valve Control Circuit Current OOR High
2357	Warning	EGR DL Motor Lock Error
2358	Warning	Utility Overvoltage
2359	Warning	EGR Delta P IR High Error
2372	Warning	Fuel Filter Pressure Above Normal
2373	Warning	Exhaust Pressure OOR High
2374	Warning	Exhaust Pressure OOR Low
2375	Warning	EGR Orifice TMPTR OOR High Error
2376	Warning	EGR Orifice TMPTR OOR Low Error
2377	Warning	High Fan Control Voltage

<b>Code</b>	<b>Lamp</b>	<b>Displayed Message</b>
2387	Warning	VGT Actuator Mechanical Sys Not Responding
2396	Warning	Utility Breaker Fail To Close
2397	Warning	Utility Breaker Fail To Open
2427	Warning	Fuel Outlet Pressure High Error
2428	Warning	Fuel Outlet Pressure Low Error
2431	Warning	Knock 1 (A1) High Warning
2432	Warning	Knock 2 (B1) High Warning
2433	Warning	Knock 3 (A2) High Warning
2434	Warning	Knock 4 (B2) High Warning
2435	Warning	Knock 5 (A3) High Warning
2436	Warning	Knock 6 (B3) High Warning
2437	Warning	Knock 7 (A4) High Warning
2438	Warning	Knock 8 (B4) High Warning
2439	Warning	Knock 9 (A5) High Warning
2441	Warning	Knock 10 (B5) High Warning
2442	Warning	Inj Solenoid Driver 1 Calib Error
2443	Warning	Inj Solenoid Driver 2 Calib Error
2444	Warning	Inj Solenoid Driver 3 Calib Error
2445	Warning	Inj Solenoid Driver 4 Calib Error
2446	Warning	Inj Solenoid Driver 5 Calib Error
2447	Warning	Inj Solenoid Driver 6 Calib Error
2448	Warning	Coolant Level Moderately Low
2449	Shutdown	VGT Actuator Controller Out of Calibration
2453	Warning	Total Real Power Circuit OOR High
2454	Warning	Total Real Power Circuit OOR Low
2455	Warning	Speed Bias Low Error
2456	Warning	Speed Bias High Error
2457	Shutdown	Max Total Misfire Error
2458	Warning	Cylinder 2 (B1) Total Misfire Error
2459	Warning	Cylinder 4 (B2) Total Misfire Error
2461	Warning	Cylinder 6 (B3) Total Misfire Error
2462	Warning	Cylinder 8 (B4) Total Misfire Error
2463	Warning	Cylinder 10 (B5) Total Misfire Error
2464	Warning	Cylinder 12 (B6) Total Misfire Error

<b>Code</b>	<b>Lamp</b>	<b>Displayed Message</b>
2465	Warning	Cylinder 14 (B7) Total Misfire Error
2466	Warning	Cylinder 16 (B8) Total Misfire Error
2467	Warning	Cylinder 18 (B9) Total Misfire Error
2469	Warning	Cylinder 1 (A1) Total Misfire Error
2471	Warning	Cylinder 3 (A2) Total Misfire Error
2472	Warning	Cylinder 5 (A3) Total Misfire Error
2473	Warning	Cylinder 7 (A4) Total Misfire Error
2475	Warning	Cylinder 9 (A5) Total Misfire Error
2476	Warning	Cylinder 11 (A6) Total Misfire Error
2477	Warning	Cylinder 13 (A7) Total Misfire Error
2478	Warning	Cylinder 15 (A8) Total Misfire Error
2479	Warning	Cylinder 17 (A9) Total Misfire Error
2482	Shutdown	Start Before Ready Error
2483	Shutdown	Continuous Starter Failure Error
2484	Shutdown	Exhaust Temperature 1 (A1) Abnormal Rate
2485	Shutdown	Exhaust Temperature 3 (A2) Abnormal Rate
2486	Shutdown	Exhaust Temperature 5 (A3) Abnormal Rate
2487	Shutdown	Exhaust Temperature 7 (A4) Abnormal Rate
2488	Shutdown	Exhaust Temperature 9 (A5) Abnormal Rate
2489	Shutdown	Exhaust Temperature 11 (A6) Abnormal Rate
2491	Shutdown	Exhaust Temperature 13 (A7) Abnormal Rate
2492	Shutdown	Exhaust Temperature 15 (A8) Abnormal Rate
2493	Shutdown	Exhaust Temperature 17 (A9) Abnormal Rate
2494	Shutdown	Exhaust Temperature 2 (B1) Abnormal Rate
2495	Shutdown	Exhaust Temperature 4 (B2) Abnormal Rate
2496	Shutdown	Exhaust Temperature 6 (B3) Abnormal Rate
2497	Shutdown	Exhaust Temperature 8 (B4) Abnormal Rate
2498	Shutdown	Exhaust Temperature 10 (B5) Abnormal Rate
2499	Shutdown	Exhaust Temperature 12 (B6) Abnormal Rate
2511	Shutdown	Exhaust Temperature 14 (B7) Abnormal Rate
2512	Shutdown	Exhaust Temperature 16 (B8) Abnormal Rate
2513	Shutdown	Exhaust Temperature 18 (B9) Abnormal Rate
2514	Shutdown	Exhaust Temperature 19 (A10) Abnormal Rate
2515	Shutdown	Exhaust Temperature 20 (B10) Abnormal Rate

<b>Code</b>	<b>Lamp</b>	<b>Displayed Message</b>
2517	Warning	Compressor Outlet Pressure High Error
2518	Warning	Compressor Outlet Pressure Low Error
2521	Shutdown	Bank ID Error
2522	Shutdown	Continuous Light Knock Error 1 (A1)
2523	Shutdown	Continuous Light Knock Error 2 (B1)
2524	Shutdown	Continuous Light Knock Error 3 (A2)
2525	Shutdown	Continuous Light Knock Error 4 (B2)
2526	Shutdown	Continuous Light Knock Error 5 (A3)
2527	Shutdown	Continuous Light Knock Error 6 (B3)
2528	Shutdown	Continuous Light Knock Error 7 (A3)
2529	Shutdown	Continuous Light Knock Error 8 (B4)
2531	Shutdown	Continuous Light Knock Error 9 (A5)
2532	Shutdown	Continuous Light Knock Error 10 (B5)
2539	Warning	High Voltage Bias
2541	Warning	Low Voltage Bias
2454	Shutdown	ECM Overtemperature Error
2545	Warning	Keysw Reset Required
2553	Warning	Engine Oil Level Low Warning Error
2554	Warning	Exhaust Gas Pressure Incorrect
2555	Warning	Low GHC 1 Voltage
2556	Warning	High GHC 1 Voltage
2567	Warning	DG Air Compressor Trip Error
2568	Shutdown	Gas Supply Pressure Critical High
2569	Shutdown	Gas Supply Pressure Critical Low
2586	Event	Spark Plug 1 (A1) High Warning
2587	Event	Spark Plug 2 (B1) High Warning
2588	Event	Spark Plug 3 (A2) High Warning
2589	Event	Spark Plug 4 (BS) High Warning
2591	Event	Spark Plug 5 (A3) High Warning
2592	Event	Spark Plug 6 (B3) High Warning
2593	Event	Spark Plug 1 (A1) Low Warning
2594	Event	Spark Plug 2 (B1) Low Warning
2595	Event	Spark Plug 3 (A2) Low Warning
2596	Event	Spark Plug 4 (B2) Low Warning

<b>Code</b>	<b>Lamp</b>	<b>Displayed Message</b>
2597	Event	Spark Plug 5 (A3) Low Warning
2598	Event	Spark Plug 6 (B3) Low Warning
2619	Warning	Aux101 0 Input 1 Fault
2621	Warning	Aux101 0 Input 2 Fault
2622	Warning	Aux101 0 Input 3 Fault
2623	Warning	Aux101 0 Input 4 Fault
2624	Warning	Aux101 0 Input 5 Fault
2625	Warning	Aux101 0 Input 6 Fault
2626	Warning	Aux101 0 Input 7 Fault
2627	Warning	Aux101 0 Input 8 Fault
2628	Warning	Aux102 0 Expansion Input 9 Fault
2629	Warning	Aux102 0 Expansion Input 10 Fault
2631	Warning	Aux102 0 Expansion Input 11 Fault
2632	Warning	Aux102 0 Expansion Input 12 Fault
2634	Shutdown	VGT Actuator Controller Bad Device/Component
2635	Shutdown	VGT Actuator Driver Condition Exists
2636	Shutdown	VGT Actuator Circuit Abnormal Update Rate
2637	Event	Aftertreatment Catalyst Face Plugged Reason Unknown
2643	Warning	Throttle Position 2 Feedback OOR High
2644	Warning	Throttle Position 2 Feedback OOR Low
2646	Warning	HT Coolant Temperature Condition Exists
2651	Event	Exhaust Gas Temperature Right Manifold OOR High
2652	Event	Exhaust Gas Temperature Right Manifold OOR Low
2653	Warning	Exhaust St 2 Temp High
2654	Shutdown	Exhaust Stack Temp Right Bank Above Sh Threshold
2655	Event	Exhaust Gas Temperature Left Manifold OOR High
2656	Event	Exhaust Gas Temperature Left Manifold OOR Low
2657	Warning	Exhaust St 1 Temp High
2658	Shutdown	Exhaust Stack Temp Left Bank Above Sh Threshold
2661	Shutdown	At Least One Unacknowledged Most Severe Fault 0 Condition Exists
2662	Warning	At Least One acknowledged: Most Severe Fault
2678	Warning	Charging Alternator Fail
2724	Warning	Gas Supply Pressure Moderate High
2725	Warning	Gas Supply Pressure Moderate Low

<b>Code</b>	<b>Lamp</b>	<b>Displayed Message</b>
2727	Warning	Critical CEN Not Accessible Error
2737	Shutdown	Exhaust Gas Temperature Critical High
2738	Warning	Ether INJ Low CTRL Error
2739	Warning	Ether INJ High CTRL Error
2752	Shutdown	Throttle Actuator - Shorted High
2753	Shutdown	Exhaust Gas Recirculation Temperature Above Normal
2754	Warning	Diesel Particulate Filter Int Pressure Above Normal
2765	Event	Engine Inj Bank 1 Barcode Out Of Calibration
2766	Shutdown	Bank A CCD Failed Error
2767	Shutdown	Bank B CCD Failed Error
2768	Shutdown	CAN Parent Communication Incorrect
2769	Shutdown	CAN Child Communication Incorrect
2774	Warning	EGR DP Clogged Tubes Error
2777	Event	Particulate Trap Regen Inhibit Condition Exists
2779	Event	Utility Unloaded Event
2789	Warning	COT Low Error
2793	Shutdown	COT Low Serious Error
2794	Warning	Ignition Shutdown Relay OOR High
2795	Warning	Ignition Shutdown Relay OOR Low
2796	Warning	Partial Engine Overload Warning Error
2797	Warning	Inlet Gas Diff Pressure OOR High
2798	Warning	Inlet Gas Diff Pressure OOR Low
2799	Shutdown	IMOP Compressor Outlet Pressure Delta Error
2811	Shutdown	IMOP Compressor Outlet Pressure Maximum Error
2812	Shutdown	Throttle Control Actuator Error
2814	Shutdown	Genset CT Ratio Low
2815	Warning	Genset CT Ratio High
2816	Shutdown	Genset PT Ratio Low
2817	Warning	Genset PT Ratio High
2818	Shutdown	Bus PT Ratio Low
2819	Warning	Bus PT Ratio High
2821	Warning	Utility PT Ratio Low
2822	Warning	Utility PT Ratio High
2837	Warning	Exhaust Temperature 1 (A1) Deviation Error

<b>Code</b>	<b>Lamp</b>	<b>Displayed Message</b>
2838	Warning	Exhaust Temperature 3 (A2) Deviation Error
2839	Warning	Exhaust Temperature 5 (A3) Deviation Error
2841	Warning	Exhaust Temperature 7 (A4) Deviation Error
2842	Warning	Exhaust Temperature 9 (A5) Deviation Error
2843	Warning	Exhaust Temperature 11 (A6) Deviation Error
2844	Warning	Exhaust Temperature 13 (A7) Deviation Error
2845	Warning	Exhaust Temperature 15 (A8) Deviation Error
2846	Warning	Exhaust Temperature 17 (A9) Deviation Error
2847	Warning	Exhaust Temperature 2 (B1) Deviation Error
2848	Warning	Exhaust Temperature 4 (B2) Deviation Error
2849	Warning	Exhaust Temperature 6 (B3) Deviation Error
2851	Warning	Exhaust Temperature 8 (B4) Deviation Error
2852	Warning	Exhaust Temperature 10 (B5) Deviation Error
2853	Warning	Exhaust Temperature 12 (B6) Deviation Error
2854	Warning	Exhaust Temperature 14 (B7) Deviation Error
2855	Warning	Exhaust Temperature 16 (B8) Deviation Error
2856	Warning	Exhaust Temperature 18 (B9) Deviation Error
2857	Shutdown	Turbo 1 Overspeed Critical Error
2858	Shutdown	Turbo 2 Overspeed Critical Error
2859	Warning	Alt Heater ctrl OOR High
2861	Warning	Alt Heater ctrl OOR Low
2862	Warning	Gen Alternator 1st Start Cond Exists
2863	Shutdown	Genset to Engine Com Incorrect
2864	Shutdown	FSO NON High Control Error
2866	Warning	FCV Position High Error
2867	Warning	FCV Position Low Error
2868	Warning	Engine Heater Over-Temperature Alarm Error
2869	Warning	HT Cool Temp Driver OOR High
2871	Warning	HT Cool Temp Driver OOR Low
2872	Warning	HT Cool Temp Driver Cond Exists
2873	Warning	LT Cool Temp Driver OOR High
2874	Warning	LT Cool Temp Driver OOR Low
2875	Warning	LT Cool Temp Driver Cond Exists
2876	Shutdown	Comp Surge Shutdown Error

<b>Code</b>	<b>Lamp</b>	<b>Displayed Message</b>
2877	Warning	Comp Surge Derate Error
2882	Warning	Aux101 1 Input 1 Fault
2883	Warning	Aux101 1 Input 2 Fault
2884	Warning	Aux101 1 Input 3 Fault
2885	Warning	Aux101 1 Input 4 Fault
2886	Warning	Aux101 1 Input 5 Fault
2887	Warning	Aux101 1 Input 6 Fault
2888	Warning	Aux101 1 Input 7 Fault
2889	Warning	Aux101 1 Input 8 Fault
2891	Warning	Aux102 1 Expansion Input 9 Fault
2892	Warning	Aux102 1 Expansion Input 10 Fault
2893	Warning	Aux102 1 Expansion Input 11 Fault
2894	Warning	Aux102 1 Expansion Input 12 Fault
2895	Warning	PCCNet Device Failed
2896	Shutdown	Critical PCCNet Dev Fail
2912	Shutdown	Voltage Reconnection Switch Operated
2913	Warning	Reconnection Switch Operated
2914	Shutdown	Genset AC Meter Failed
2915	Warning	Gen Bus AC Meter Failed
2916	Warning	Utility AC Meter Failed
2917	Warning	Gen Bus Voltage OOR Hi
2918	Warning	Utility Voltage OOR Hi
2919	Warning	Utility Current OOR Hi
2921	Warning	Gen Bus Current OOR Hi
2922	Warning	High Genset Neutral Curr
2923	Warning	Gen Bus kW OOR Hi
2924	Warning	Gen Bus kVAR OOR Hi
2925	Warning	Gen Bus kVA OOR Hi
2926	Warning	Utility kW OOR Hi
2927	Warning	Utility kVAR OOR Hi
2928	Warning	Utility kVA OOR Hi
2931	Shutdown	Aux101 Device ID Fault
2932	Warning	Aux101 Oil Temperature OOR Hi
2933	Warning	Aux101 Oil Temperature OOR Low

<b>Code</b>	<b>Lamp</b>	<b>Displayed Message</b>
2934	Warning	High Ambient Temp
2935	Warning	Low Ambient Temp
2936	Warning	Fuel Level High
2937	Warning	Fuel Level Low
2938	Warning	Earth/Ground Fault
2939	Warning	Modbus Failure
2941	Event	Remote Shutdown Fault Reset Occurrence
2942	Warning	Shutdown Override Fail
2943	Warning	Manual Sw Config Fail
2944	Warning	Auto Switch Config Fail
2945	Warning	Rupture Basin Switch
2946	Warning	Exhaust St 2 Temp Low
2947	Warning	Exhaust St 1 Temp Low
2948	Warning	Exhaust St 2 Temp High
2949	Warning	Exhaust St 1 Temp High
2951	Warning	Alternator 1 Temp High
2952	Warning	Alternator 1 Temp Low
2953	Warning	Alternator 1 Temp High
2954	Warning	Alternator 2 Temp High
2955	Warning	Alternator 2 Temp Low
2956	Warning	Alternator 2 Temp High
2957	Warning	Alternator 3 Temp High
2958	Warning	Alternator 3 Temp Low
2959	Warning	Alternator 3 Temp High
2961	Event	EGR Torque Derate Error
2962	Warning	EGR RPM Derate Error
2963	Event	HT Coolant Temperature Warning High
2964	Warning	Pre-high Intake Manifold Temperature
2965	Event	Genset Available
2971	Event	Test/Exercise Fault
2972	Shutdown	Field Overload
2973	Warning	Charge Press IR Error
2977	Warning	Low Coolant Level 2 Sw
2978	Warning	Low Intake Manf 1 Temp

<b>Code</b>	<b>Lamp</b>	<b>Displayed Message</b>
2979	Warning	High Alternator Temp Sw
2981	Warning	High Drive Bearing Temp
2982	Warning	Low Drive Bearing Temp
2983	Warning	High Drive Bearing Temp
2984	Warning	High Free Bearing Temp
2985	Warning	Low Free Bearing Temp
2986	Warning	High Free Bearing Temp
2992	Warning	High Intake Manf 1 Temp
2993	Warning	Battery Charger Sw Fail
2994	Shutdown	MC68302 Error
2995	Shutdown	Int Man Pressure 1 Critical High
2996	Shutdown	Int Man Pressure 1 Moderate High
2997	Shutdown	Exhaust O2 Critical Low
3111	Shutdown	Excessive Mech Vibration 1 (A1)
3112	Shutdown	Excessive Mech Vibration 2 (B1)
3113	Shutdown	Excessive Mech Vibration 3 (A2)
3114	Shutdown	Excessive Mech Vibration 4 (B2)
3115	Shutdown	Excessive Mech Vibration 5 (A3)
3116	Shutdown	Excessive Mech Vibration 6 (B3)
3117	Shutdown	Excessive Mech Vibration 7 (A4)
3118	Shutdown	Excessive Mech Vibration 8 (B4)
3119	Shutdown	Excessive Mech Vibration 9 (A5)
3121	Shutdown	Excessive Mech Vibration 10 (B5)
3122	Shutdown	Excessive Mech Vibration 11 (A6)
3123	Shutdown	Excessive Mech Vibration 12 (B6)
3124	Shutdown	Excessive Mech Vibration 13 (A7)
3125	Shutdown	Excessive Mech Vibration 14 (B7)
3126	Shutdown	Excessive Mech Vibration 15 (A8)
3127	Shutdown	Excessive Mech Vibration 16 (B8)
3128	Shutdown	Excessive Mech Vibration 17 (A9)
3129	Shutdown	Excessive Mech Vibration 18 (B9)
3131	Shutdown	Secondary Engine Overspeed
3133	Warning	Aftertreatment Particulate Filter Outlet Pressure OOR High
3134	Warning	Aftertreatment Particulate Filter Outlet Pressure OOR Low

<b>Code</b>	<b>Lamp</b>	<b>Displayed Message</b>
3135	Warning	Aftertreatment Particulate Filter Pressure Data Erratic
3226	Event	Base Load
3227	Event	Peak Shave
3228	Warning	Aftertreatment Intake Nox Sensor: Data Incorrect *
3232	Warning	Aftertreatment Intake Nox Sensor: Abnormal Update *
3245	Warning	Aftertreatment Particulate Filter System: Not Responding *
3251	Shutdown	Aftertreatment Catalyst Intake Temp: Data Valid: Above Normal *
3253	Shutdown	Particulate Filter Int Temp: Above Normal Mod Sev *
3254	Warning	Particulate Filter Int Temp: Above Normal *
3255	Shutdown	Particulate Filter Out Temp: Above Normal Mod Sev
3256	Warning	Particulate Filter Outlet Temp: Above Normal
3262	Event	Spark Plug 7 (A4) High Warning
3263	Event	Spark Plug 7 (A4) Low Warning
3264	Event	Spark Plug 8 (B4) High Warning
3265	Event	Spark Plug 8 (B4) Low Warning
3266	Event	Spark Plug 9 (A5) High Warning
3267	Event	Spark Plug 9 (A5) Low Warning
3268	Event	Spark Plug 10 (B5) High Warning
3269	Event	Spark Plug 10 (B5) Low Warning
3271	Event	Spark Plug 11 (A6) High Warning
3272	Event	Spark Plug 11 (A6) Low Warning
3273	Event	Spark Plug 12 (B6) High Warning
3274	Event	Spark Plug 12 (B6) Low Warning
3275	Event	Spark Plug 13 (A7) High Warning
3276	Event	Spark Plug 13 (A7) Low Warning
3277	Event	Spark Plug 14 (B7) High Warning
3278	Event	Spark Plug 14 (B7) Low Warning
3279	Event	Spark Plug 15 (A8) High Warning
3281	Event	Spark Plug 15 (A8) Low Warning
3282	Event	Spark Plug 16 (B8) High Warning
3283	Event	Spark Plug 16 (B8) Low Warning
3284	Event	Spark Plug 17 (A9) High Warning
3285	Event	Spark Plug 17 (A9) Low Warning
3286	Event	Spark Plug 18 (B9) High Warning

<b>Code</b>	<b>Lamp</b>	<b>Displayed Message</b>
3287	Event	Spark Plug 18 (B9) Low Warning
3288	Warning	Exhaust Aftertreatment Outlet Oxygen Relay OOR High
3289	Warning	Exhaust Aftertreatment Outlet Oxygen Relay OOR Low
3291	Warning	Exhaust Aftertreatment Inlet Oxygen Relay OOR High
3292	Warning	Exhaust Aftertreatment Inlet Oxygen Relay OOR Low
3293	Warning	Exhaust Oxygen Relay OOR High
3294	Warning	Exhaust Oxygen Relay OOR Low
3311	Shutdown	Particulate Filter Int Temp: Above Normal Severe
3312	Shutdown	Particulate Filter Out Temp: Above Normal Severe
3313	Warning	Aftertreatment Catalyst Intake Temperature: Below Normal
3314	Warning	Aftertreatment Catalyst Intake Temperature: Above Normal
3315	Warning	Aftertreatment Catalyst Intake Temperature: Incorrect
3316	Warning	Aftertreatment Particulate Filter Intake Temperature: OOR Low
3317	Warning	Aftertreatment Particulate Filter Intake Temperature: OOR High
3318	Warning	Aftertreatment Particulate Filter Intake Temp: Data Incorrect
3319	Warning	Aftertreatment Particulate Filter Outlet Temp Circuit: OOR High
3321	Warning	Aftertreatment Particulate Filter Outlet Temp Circuit: OOR Low
3322	Warning	Aftertreatment Particulate Filter Outlet Temp Circuit: Data Incorrect
3325	Warning	Aftertreatment Catalyst Intake Temp Swapped: Out Of Cal
3329	Event	J1939 Network 2 Data Incorrect
3331	Event	J1939 Network 3 Data Incorrect
3362	Warning	Power Conservation Control OOR High
3363	Warning	Power Conservation Control OOR Low
3364	Warning	Power Conservation Control Cond Exists
3365	Warning	External Air Pressure Low Warning Error
3384	Warning	Manifold Absolute Pressure 2 High Error
3391	Warning	Manifold Absolute Pressure 2 Low Error
3392	Shutdown	Int Man Pressure 2 Critical High
3393	Warning	Int Man Pressure 2 Moderate High
3397	Shutdown	Low Gearbox Oil Pressure – Condition Exists
3398	Shutdown	High Gearbox Oil Pressure – Condition Exists
3399	Shutdown	Differential Fault – Condition Exists
3411	Warning	DC Power Supply Fault – Condition Exists
3412	Warning	GIB Isolator Open Fault – Condition Exists

<b>Code</b>	<b>Lamp</b>	<b>Displayed Message</b>
3413	Warning	Radiator Fan Trip Fault – Condition Exists
3414	Warning	Ventilator Fan Trip Fault – Condition Exists
3415	Warning	Louvres Closed Fault – Condition Exists
3416	Warning	Start System Fault – Condition Exists
3417	Warning	Alternator Heater Trip Fault – Condition Exists
3457	Warning	Loss of Bus Voltage Sensing
3458	Warning	Knock Engine Derate
3475	Warning	Engine Electronic Fuel Valve #2 OOR High
3476	Warning	Engine Electronic Fuel Valve #2 OOR Low
3477	Warning	Fuel Actuator 2 Control Valve: Out of Adjustment
3479	Shutdown	Start-Inhibit Warning Fault Event
3481	Event	Start-Inhibit Warning Fault Event
3482	Shutdown	Start-Inhibit Shutdown Fault
3483	Shutdown	High Alternator Temperature 1 Shutdown Fault
3484	Shutdown	High Alternator Temperature 2 Shutdown Fault
3485	Shutdown	High Alternator Temperature 3 Shutdown Fault
3486	Shutdown	High Drive End Bearing Temperature Shutdown Fault
3487	Shutdown	High Non-Drive End Bearing Temp Shutdown Fault
3489	Warning	Compressor Bypass Actuator Error
3491	Shutdown	Oil Filter Restriction High
3499	Shutdown	Throttle Actuator 2- Special Instruction
3511	Shutdown	Throttle Actuator 2- Shorted High
3512	Shutdown	Throttle Actuator 2- Shorted Low
3513	Warning	Negative Sequence Overcurrent
3514	Shutdown	Throttle Actuator - Shorted Low
3515	Shutdown	Throttle Actuator - Special Instruction
3521	Warning	Throttle Actuator - Temperature Low
3522	Warning	Throttle Actuator 2- Temperature Low
3584	Shutdown	Engine Derate: Special
3585	Warning	Generator Total Real Power: Root Cause Unknown
3586	Warning	Generator Total Real Power: Data Incorrect
3587	Warning	Methane Percent Signal: Below Normal Least Severe
3588	Shutdown	Methane Percent Signal: Below Normal Most Severe
3589	Warning	Methane Percent Signal: Data Incorrect

<b>Code</b>	<b>Lamp</b>	<b>Displayed Message</b>
3591	Shutdown	Methane Percent Signal: Special
3592	Warning	Methane Percent Signal: Current Above Normal
3593	Warning	Methane Percent Signal: Current Below Normal
3594	Warning	Engine Emissions Closed Loop Fueling Adjust: Condition Exists
3595	Shutdown	Engine Emissions Closed Loop Fueling Adjust: Root Cause Unknown
3599	Warning	Ground Current OOR Warning
3611	Warning	Custom Overcurrent Fault
3629	Warning	Device Calibration Update Recommended
3631	Shutdown	Device Calibration Update Required
3641	Shutdown	Start Enable Line 1 Disabled
3642	Shutdown	Start Enable Line 2 Disabled
3643	Shutdown	Start Enable Line 3 Disabled
3644	Shutdown	Intake Manifold Temperature: Special
3645	Shutdown	Intake Manifold 2 Temperature: Special
3646	Shutdown	Intake Manifold 3 Temperature: Special
3647	Shutdown	Intake Manifold 4 Temperature: Special
3682	Warning	Aftertreatment Intake Nox: Power Supply Data Incorrect
3694	Warning	Gain Adjust Potentiometer Circuit: OOR Low
3695	Warning	Frequency Adjust Potentiometer Circuit: OOR Low
3696	Warning	Droop Adjust Potentiometer Circuit: OOR Low
3697	Shutdown	RAM Refresh Error
3718	Warning	Aftertreatment Intake Nox Sensor: Out of Cal
3724	Warning	Battery 1 Voltage: Below Normal
3727	Event	Common Rail Fuel Press Relief Valve: Not Resp
3728	Shutdown	Engine Throttle Control Actuator: Network Error
3741	Warning	Common Rail Fuel Pressure: Above Normal
3846	Warning	Fuel Actuator Control: Data Above Normal Least Severe
3847	Warning	Fuel Actuator Control: Data Below Normal Least Severe
3848	Shutdown	Fuel Actuator Control: Special
3849	Shutdown	Fuel Actuator Control: Bad Device
3851	Shutdown	Fuel Actuator Control: Network Error
3852	Warning	Fuel Actuator 2 Control Valve: Data Above Normal Least Severe
3853	Warning	Fuel Actuator 2 Control Valve: Data Below Normal Least Severe
3854	Shutdown	Fuel Actuator 2 Control Valve: Special

<b>Code</b>	<b>Lamp</b>	<b>Displayed Message</b>
3855	Shutdown	Fuel Actuator 2 Control Valve: Bad Device
3856	Shutdown	Fuel Actuator 2 Control Valve: Network Error
3857	Warning	Fuel Actuator 2 Control Valve: Root Cause Unknown
3858	Warning	Engine Turbocharger Compressor: Above Normal Least Severe
3859	Warning	Engine Turbocharger Compressor: Below Normal Least Severe
3861	Warning	Engine Turbocharger Compressor: Root Cause Unknown
3862	Warning	Engine Turbocharger Compressor Bypass Actuator: Special
3863	Shutdown	Engine Turbocharger Compressor Bypass Actuator: Bad Compressor
3864	Warning	Engine Turbocharger Compressor Bypass Actuator: N/W error
3869	Warning	LVRT Device Error
3871	Warning	LVRT Engine Governing Message Lost Error
3872	Warning	LVRT Count Warning Error
3873	Shutdown	LVRT Count Serious Error
3874	Warning	LVRT Stuck On Error
3875	Warning	LVRT Detection Error
3931	Shutdown	Inducement Fault: Impact on Engine Emissions
4135	Warning	Inducement Approaching: Performance is Active
4285	Shutdown	LVRT Shutdown Fault
4358	Shutdown	Setup Mode Shutdown
4437	Event	J1939 Network 4 Data Incorrect
4615	Shutdown	Fuel Delivery Pressure Above Normal
4642	Shutdown	Water In Fuel Above Normal
4643	Warning	Injector Solenoid Driver 7 Calib Error
4644	Warning	Injector Solenoid Driver 8 Calib Error
4645	Warning	Injector Solenoid Driver 9 Calib Error
4646	Warning	Injector Solenoid Driver 10 Calib Error
4647	Warning	Injector Solenoid Driver 11 Calib Error
4648	Warning	Injector Solenoid Driver 12 Calib Error
4649	Warning	Injector Solenoid Driver 13 Calib Error
4651	Warning	Injector Solenoid Driver 14 Calib Error
4652	Warning	Injector Solenoid Driver 15 Calib Error
4653	Warning	Injector Solenoid Driver 16 Calib Error
4696	Warning	Crankcase Pressure 2 OOR High
4697	Warning	Crankcase Pressure 2 OOR Low

<b>Code</b>	<b>Lamp</b>	<b>Displayed Message</b>
4698	Event	Crankcase Pressure 2 Above Normal
4699	Warning	Crankcase Pressure 2 Moderate High
4711	Event	Crankcase Pressure 2 Below Normal
4761	Shutdown	Genset Voltage Sensing MCB Protection
4766	Warning	Customer Gas Valve Close Warning
4767	Shutdown	Customer Gas Valve Close Shutdown
4872	Warning	System Network Failure
4873	Warning	Genset Failed to Come Online
4874	Warning	Load Demand Version Incompatibility
4875	Event	Genset Ineligible For Load Demand
4876	Warning	Genset Lost On System Network
4877	Warning	System Settings Not Synchronized
4878	Warning	Check System Network Installation
4879	Warning	Load Demand Setup Error
4881	Warning	System Genset ID Conflict
4882	Warning	Genset Bus Overload
4883	Warning	Prelube Cycle Failed
4884	Warning	Prelube Pump Stuck ON
4885	Shutdown	Fuel Supply Pump Not Responding
4886	Warning	Fuel Pump Voltage Moderate Low
4887	Shutdown	Fuel Supply Voltage Below Normal
4888	Shutdown	Fuel Supply Temperature: Moderate High
4889	Shutdown	Fuel Supply Temperature Critical High
4891	Warning	Fuel Supply Pump Root Unknown Cause
4982	Warning	Fuel Supply Pump Update Rate Error
4893	Warning	Fuel Filter Press Moderate High
4894	Warning	Fuel Supply Pump Calib Error
4927	Warning	Fuel Valve 1 Bad Device
4928	Warning	Fuel Valve 1 Power Supply Data Incorrect
4929	Warning	Fuel Valve 1 Power Supply OOR High
4931	Warning	Fuel Valve 1 Power Supply OOR Low
4932	Event	Fuel Valve 1 Temp Above Normal
4933	Event	Fuel Valve 1 Position Data Error
4934	Warning	Fuel Valve 1 Voltage OOR High

<b>Code</b>	<b>Lamp</b>	<b>Displayed Message</b>
4935	Warning	Fuel Valve 1 Voltage OOR Low
4936	Warning	Fuel Valve 1 Unknown Cause
4937	Warning	Fuel Valve 1 Calib Error
4941	Warning	Starter Control Voltage OOR High
4942	Warning	Starter Control Voltage OOR Low
4943	Warning	Failed To Crank Condition Exists
4944	Warning	Failed To Start Condition Exists
4945	Warning	Uncommanded Crank Cond Exists
4946	Event	Engine Crank Without Prelube Condition Exists
4958	Warning	Fuel Valve 1 Data Incorrect
4959	Event	Fuel Valve 1 Condition Exists
4961	Event	Fuel Valve 1 Update Rate Error
5119	Warning	Fuel Pump Oil Pressure Sensor OOR High
5121	Warning	Fuel Pump Oil Pressure Sensor OOR Low
5122	Warning	Fuel Pump Oil Pressure Sensor Data Incorrect
5123	Warning	Injector Solenoid 19 Low Current
5124	Warning	Injector Solenoid 20 Low Current
5135	Shutdown	Genset Overload
5145	Warning	Load Demand Genset Bus Failure
5148	Warning	Allow Start Override Active Condition Exists
5149	Warning	Prelube Cycle failed during Non-Emergency Start
5151	Warning	Intake air restriction indicator 1 active
5152	Warning	Intake air restriction indicator 2 active
5153	Warning	Intake air restriction indicator 3 active
5154	Warning	Intake air restriction indicator 4 active
5155	Warning	Low Battery 1 Voltage
5156	Warning	Low Battery 2 Voltage
5157	Warning	Low Battery 3 Voltage
5158	Warning	Low Battery 4 Voltage
5159	Warning	Weak Battery 1
5161	Warning	Weak Battery 2
5162	Warning	Weak Battery 3
5163	Warning	Weak Battery 4
5164	Warning	Battery Charger 2 Failed Fault

<b>Code</b>	<b>Lamp</b>	<b>Displayed Message</b>
5165	Warning	Battery Charger 3 Failed Fault
5166	Warning	Battery Charger 4 Failed Fault
5178	Warning	Crankcase Pressure 2 Data Incorrect
5182	Warning	AUX101 0 Input 1 Fault
5283	Warning	High Battery 1 Voltage
5284	Warning	High Battery 2 Voltage
5285	Warning	High Battery 3 Voltage
5286	Warning	High Battery 4 Voltage
5287	Warning	Starter Air Supply Pressure Low
5288	Warning	Starter Air Tank Volume Low
5377	Warning	AUX101-3 Communication Lost Fault
5378	Warning	AUX101-4 Communication Lost Fault
5397	Shutdown	L-N Short Circuit Shutdown
5398	Shutdown	L-L Short Circuit Shutdown
5399	Event	AmpSentry Maintenance Mode Active
5531	Shutdown	Cam Position Frequency Mismatch
8632	Warning	DC Box F18 Fuse Blown
9945	Warning	Injector 6 Circuit 2 Error
9946	Warning	Injector 5 Circuit 2 Error
9947	Warning	Injector 4 Circuit 2 Error
9948	Warning	Injector 3 Circuit 2 Error
9949	Warning	Injector 2 Circuit 2 Error
9951	Warning	Injector 1 Circuit 2 Error
9971	Event	ECM Derate Fault
9973	Event	Watchdog Reset Occurence

## 7.5.4 Troubleshooting Procedures for Fault Codes

TABLE 33. TROUBLESHOOTING PROCEDURES FOR FAULT CODES

Fault Code	Corrective Action – (if in doubt, call your authorized service technician)
CODE: <b>143</b> LAMP: <b>Warning</b> MESSAGE: <b>Low Oil Rifle Pressure</b>	Indicates engine oil pressure has dropped below the warning trip point. If the generator set is powering critical loads and cannot be shut down, wait until the next shutdown period and then follow the fault code 415 procedure.
CODE: <b>144</b> LAMP: <b>Warning</b> MESSAGE: <b>High Coolant 1 Temp</b>	Indicates the engine has begun to overheat and engine coolant temperature has risen to an unacceptable level. Increase in load or higher ambient temperature may cause a High Coolant Temp (151) shutdown. Review fault code 151 correction list for other possible causes.
CODE: <b>145</b> LAMP: <b>Warning</b> MESSAGE: <b>Low Coolant 1 Temp</b>	Engine coolant temperature is below the low coolant temperature warning threshold. If the generator set is powering critical loads and cannot be shut down, wait until the next shutdown period and then follow the fault code 1435 procedure.
CODE: <b>146</b> LAMP: <b>Derate</b> MESSAGE: <b>Pre-High Engine Coolant Temperature</b>	Indicates the engine is operating near cooling system capacity. Increase in load or higher ambient temperature may cause a High Coolant Temp (151) shutdown. Review fault code 151 correction list for other possible causes.
CODE: <b>151</b> LAMP: <b>Shutdown</b> MESSAGE: <b>High Coolant Temp</b>	Indicates the engine has overheated (coolant temperature has risen above the shutdown trip point or coolant level is low). Allow the engine to cool down completely before proceeding with the following checks: <ol style="list-style-type: none"> <li>1. Look for possible coolant leakage points and repair if necessary. Check the coolant level and replenish if low.</li> <li>2. Check for obstructions to cooling airflow and correct as necessary.</li> <li>3. Check the fan belt and repair or tighten if necessary.</li> <li>4. Check the blower fan and circulation pumps on remote radiator installations.</li> <li>5. Reset the control and restart after locating and correcting the problem.</li> </ol>
CODE: <b>155</b> LAMP: <b>Shutdown</b> MESSAGE: <b>High Intake Manf 1 Temp</b>	Indicates the engine has overheated (intake manifold temperature has risen above the shutdown trip point). Large load or high ambient temperature may be the cause. Review fault code 151 correction list for other possible causes.
CODE: <b>196</b> LAMP: <b>Warning</b> MESSAGE: <b>Low Coolant 1 Level</b>	Indicates engine coolant level has fallen below the trip point. If the generator is powering critical loads and cannot be shut down, wait until the next shutdown period. If the engine can be stopped, allow the engine to cool down completely before proceeding: <ol style="list-style-type: none"> <li>1. Look for possible coolant leakage points and repair if necessary.</li> <li>2. Check coolant level and replenish if low.</li> <li>3. Reset the control and restart after locating and correcting the problem.</li> </ol>

Fault Code	Corrective Action – (if in doubt, call your authorized service technician)
CODE: 197	Indicates the engine coolant level has fallen below the trip point. If the generator is powering critical loads and cannot be shut down, wait until the next shutdown period. If the engine can be stopped, allow the engine to cool down completely before proceeding:
LAMP: <b>Warning</b>	
MESSAGE: <b>Low Coolant Level</b>	
CODE: 235	Low Coolant Level input is active and the threshold response is set to Shutdown. Allow the engine to cool down completely before proceeding:
LAMP: <b>Shutdown</b>	
MESSAGE: <b>Low Coolant Level</b>	
CODE: 359	Indicates a possible fault with the control or starting system (engine cranks but fails to start). Allow the engine to cool down completely before proceeding with the following checks:
LAMP: <b>Shutdown</b>	
MESSAGE: <b>Fail To Start</b>	
CODE: 415	Indicates the engine oil pressure has dropped below the shutdown trip point. Allow the engine to cool down completely before proceeding with the following checks:
LAMP: <b>Shutdown</b>	
MESSAGE: <b>Low Oil Rifle press</b>	
CODE: 427	Communication between the engine control (ECM) and the PCC is severed. Allow the engine to cool down completely before proceeding:
LAMP: <b>Warning</b>	
MESSAGE: <b>CAN Data Link Degraded</b>	
CODE: 441	Indicates battery voltage is below 24 VDC and is approaching a low level at which unpredictable operation will occur. If the engine can be stopped, allow the engine to cool down completely before proceeding:
LAMP: <b>Warning</b>	
MESSAGE: <b>Low Battery 1 Voltage</b>	
CODE: 442	Indicates the battery voltage to the control is approaching a high level (exceeding 32 VDC) at which damage to the control can occur. If the engine can be stopped, allow the engine to cool down completely before proceeding:
LAMP: <b>Warning</b>	
MESSAGE: <b>High Battery 1 Voltage</b>	

Fault Code	Corrective Action – (if in doubt, call your authorized service technician)
CODE: <b>488</b> LAMP: <b>Derate</b> MESSAGE: <b>High Intake Manf 1 temp</b>	Indicates the engine has overheated (intake manifold temperature has risen above the shutdown trip point). Large load or high ambient temperature may be the cause. Review fault code 151 correction list for other possible causes.
CODE: <b>611</b> LAMP: <b>Warning</b> MESSAGE: <b>Engine Hot Shut Down</b>	Indicates that an engine hot shutdown has occurred (cooldown timers were bypassed). This condition will occur when the operator presses the Emergency Switch or presses the <b>Stop</b> button before the generator set completes the cooldown operation. (Generator set should run at 10% or less load for three minutes before engine shutdown). This type of hot shutdown should be avoided; it can cause possible loss of performance and engine damage.
CODE: <b>781</b> LAMP: <b>Shutdown</b> MESSAGE: <b>CAN Data Link Failure</b>	Communication between the engine control (ECM) and the PowerCommand® 3.3 control has been severed.  1. Ensure the E-Stop button is not active. Reset the Local/Remote Emergency Stop.
CODE: <b>1131</b> LAMP: <b>Warning</b> MESSAGE: <b>Battle Short Active</b>	Indicates that the control is in Battle Short mode (used to bypass several fault shutdowns therefore allowing generator set operation during emergencies).  1. If possible, investigate any fault codes that are being bypassed.
CODE: <b>1312, 1317, and 1318</b> LAMP: <b>Event</b> MESSAGE: <b>Configurable Input #2, 13, and 14</b>	The nature of the fault is an optional customer selection – configurable input #. Example inputs: Low Fuel Day Tank, Water In Fuel, Ground Fault, etc. Each of the fault functions can be programmed using InPower service tool or by accessing the Setup menu. If the engine can be stopped, allow the engine to cool down completely before proceeding:  1. Check the Input # requirements and correct if possible.
CODE: <b>1416</b> LAMP: <b>Warning</b> MESSAGE: <b>Fail To Shutdown</b>	Records (in the Fault History log) a bypassed shutdown fault while the generator set was in Battle Short mode (this is used to bypass several critical fault shutdowns therefore allowing generator set operation during emergencies).  1. Event/fault 1416 has been activated as a result of another active shutdown fault while the PowerCommand® 3.3 control is operating in Battle Short mode. If possible, troubleshoot this shutdown fault that is causing the generator set to shut down.
CODE: <b>1433/1434</b> LAMP: <b>Shutdown</b> MESSAGE: <b>Local Emergency Stop/Remote Emergency Stop</b>	Indicates a local or remote Emergency Stop has been activated. Emergency Stop shutdown status can be reset only at the local control panel. Allow the engine to cool down completely before proceeding with the following checks:  1. After locating and correcting problem, reset the local/remote Emergency Stop button as follows: <ol style="list-style-type: none"> <li>a. De-activate (disable) the <b>Emergency Stop</b> button.</li> <li>b. Press the <b>Stop</b> button.</li> <li>c. Press the <b>Reset</b> button.</li> <li>d. Select the desired operating mode (manual or auto).</li> </ol> 2. Check the Emergency Stop button is working correctly

Fault Code	Corrective Action – (if in doubt, call your authorized service technician)	
CODE: 1435	<p>Indicates the engine coolant heater is not operating or is not circulating coolant. If the engine can be stopped, allow the engine to cool down completely before proceeding with the following checks:</p> <ol style="list-style-type: none"> <li data-bbox="435 338 1393 394">1. The coolant heater is not connected to a power supply. Check for a blown fuse or disconnected heater cable and correct as required.</li> <li data-bbox="435 405 1084 432">2. Look for possible coolant leaks and repair as required.</li> <li data-bbox="435 443 1065 470">3. Check for low coolant level and replenish if required.</li> </ol> <p>Generator set is not operating. This warning occurs when the engine coolant temperature is 21 °C (70 °F) or lower.</p>	
LAMP: <b>Warning</b>		
MESSAGE: <b>Low Coolant Temperature</b>		<div style="background-color: #0070C0; color: white; text-align: center; padding: 5px;"><b>NOTICE</b></div> <p><b>In applications where the ambient temperature falls below 4 °C (40 °F), Low Coolant Temp may be indicated even though the coolant heaters are operating.</b></p>
CODE: 1438	<p>Indicates a possible fault with the control, speed sensing, or starting system. Allow the engine to cool down completely before proceeding with the following checks:</p> <ol style="list-style-type: none"> <li data-bbox="435 831 1450 888">1. Indicates a possible fault with the control, speed sensing, or starting system. See code 441 for corrective action</li> <li data-bbox="435 898 1040 926">2. Ensure the Emergency Stop button is disengaged.</li> </ol>	
LAMP: <b>Shutdown</b>		
MESSAGE: <b>Fail To Crank</b>		
CODE: 1439	<p>Indicates the day tank fuel supply is running low. If the engine can be stopped, allow engine to cool down completely before proceeding with the following checks:</p> <ol style="list-style-type: none"> <li data-bbox="435 1020 1045 1050">1. Look for possible fuel leaks and repair as required.</li> <li data-bbox="435 1060 1024 1087">2. Check for low fuel level and replenish if required.</li> </ol>	
LAMP: <b>Warning</b>		
MESSAGE: <b>Low Day Tank Fuel Switch</b>		
CODE: 1441	<p>Indicates the fuel level has gone below the threshold setting for the low fuel level against the time setting. If the engine can be stopped, allow the engine to cool down completely before proceeding with the following checks:</p> <ol style="list-style-type: none"> <li data-bbox="435 1230 1045 1260">1. Look for possible fuel leaks and repair as required.</li> <li data-bbox="435 1270 1024 1297">2. Check for low fuel level and replenish if required.</li> </ol>	
LAMP: <b>Warning</b>		
MESSAGE: <b>Low Fuel Level</b>		
CODE: 1442	<p>Indicates that, during cranking, the battery voltage is at, or below the weak battery warning trip point for a time greater than, or equal to the weak battery set time. If the engine can be stopped, allow the engine to cool down completely before proceeding with the following checks:</p> <ol style="list-style-type: none"> <li data-bbox="435 1451 643 1478">1. See code 441.</li> </ol>	
LAMP: <b>Warning</b>		
MESSAGE: <b>Weak Battery</b>		
CODE: 1443	<p>During cranking, the battery voltage has dropped below the operating voltage of the PowerCommand® 3.3 control, which resets the PowerCommand® 3.3 control. After three consecutive resets, event/fault code 1443 becomes active. If the engine can be stopped, allow the engine to cool down completely before proceeding with the following checks:</p> <ol style="list-style-type: none"> <li data-bbox="435 1640 643 1667">1. See code 441.</li> </ol>	
LAMP: <b>Shutdown</b>		
MESSAGE: <b>Dead Battery</b>		
CODE: 1448	<p>Indicates that the generator set frequency has dropped below 90 % of nominal for approximately ten seconds. Allow the engine to cool down completely before proceeding with the following checks:</p> <ol style="list-style-type: none"> <li data-bbox="435 1797 727 1824">1. Check the fuel supply.</li> <li data-bbox="435 1835 789 1862">2. Check the air intake supply.</li> <li data-bbox="435 1873 938 1900">3. Check the load and correct any overload.</li> </ol>	
LAMP: <b>Shutdown</b>		
MESSAGE: <b>Under Frequency</b>		

CODE: <b>1449</b>	Indicates that the generator set frequency has exceeded the Over Frequency threshold for the set time parameter. Allow the engine to cool down completely before proceeding with the following checks:  1. Check the fuel supply. 2. Check the air intake supply. 3. Check the load and correct any overload.
LAMP: <b>Shutdown</b>	
MESSAGE: <b>Over Frequency</b>	
CODE: <b>1852</b>	Indicates that the water in the fuel is above normal and has reached the warning trip point. If the engine can be stopped, allow the engine to cool down completely before proceeding with the following checks:  1. Check fuel in tank (local or remote). 2. Drain and re-fill if necessary. Be aware of all Health and Safety, and environmental issues if draining tank.
LAMP: <b>Warning</b>	
MESSAGE: <b>Pre-High H2O In Fuel</b>	
CODE: <b>2977</b>	Indicates the engine coolant level, in the second radiator, has fallen below the trip point. If the generator is powering critical loads and cannot be shut down, wait until the next shutdown period. If the engine can be stopped, allow the engine to cool down completely before proceeding:  1. Look for possible coolant leakage points and repair if necessary. Check coolant level and replenish if low. 2. Reset the control and restart after locating and correcting the problem.
LAMP: <b>Warning</b>	
MESSAGE: <b>Low Coolant 2 Level</b>	
CODE: <b>3416</b>	Refer to fault codes 359 and 1438
LAMP: <b>Warning</b>	
MESSAGE: <b>Start System Fault – Condition Exists</b>	

## 7.6 Line Circuit Breaker

A line circuit breaker is mounted in the generator output box. If the load exceeds the circuit breaker current rating, the line circuit breaker will open, preventing the generator set from being overloaded. If the circuit breaker trips, locate the source of the overload or short circuit, and correct/eliminate the fault. Manually reset the breaker. Clear any fault messages and when safe to do so, reconnect the load to the generator.

### 7.6.1 Circuit Breaker Location

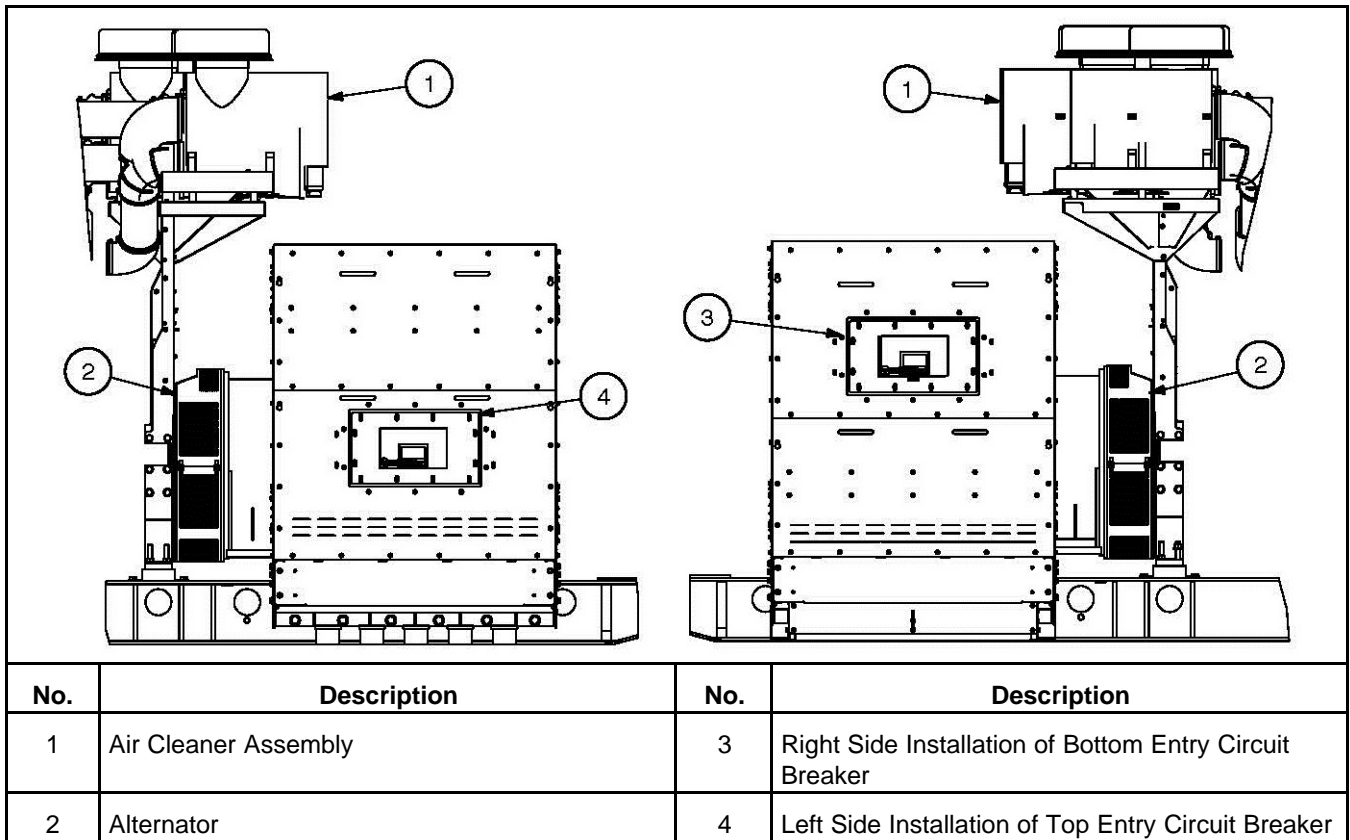

**FIGURE 77. CIRCUIT BREAKER LOCATION**

# 8 Battery Charger

---

## 8.1 Battery Charger - 15 Amp/12 Volt and 12 Amp/24 Volt

There are two types of 15/12-Amp PowerCommand battery chargers. All 15/12-Amp battery chargers have a 20 Amp DC circuit breaker switch on the front of the battery charger. The 120, 208, and 240 VAC battery chargers include two 10 Amp AC circuit breaker switches, all other models include two AC fuse holders.

Refer to the battery charger Owner Manual (901-0107) for more information.

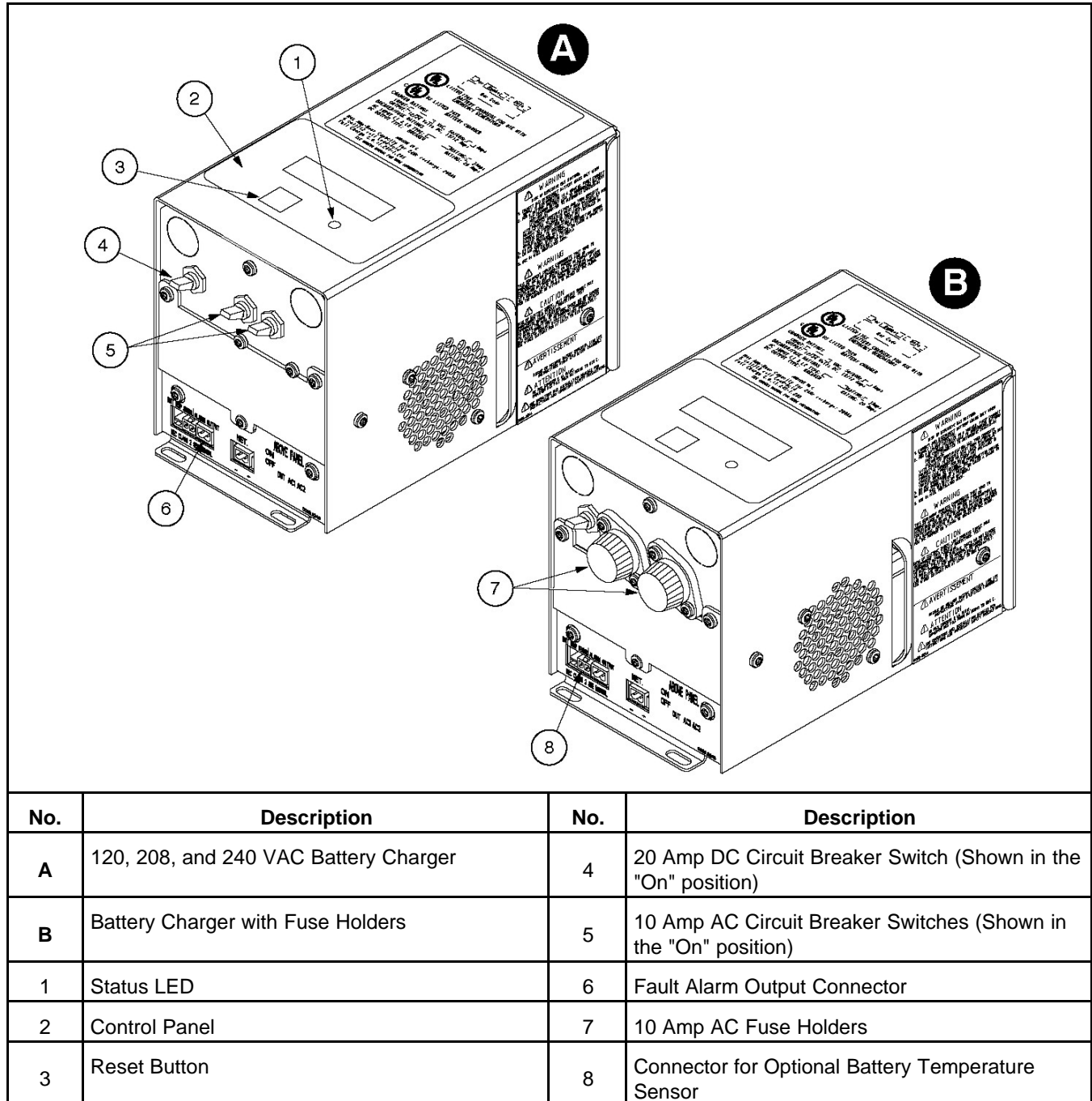

FIGURE 78. 15/12-AMP POWERCOMMAND BATTERY CHARGERS

### 8.1.1 Battery Charger Control Panel

The 15/12-amp charger control panel includes a digital display, a Reset button, and an LED status indicator.

- The 2-line x 16-character digital display displays menus and faults.
- The Reset button is used to select menu options and to clear fault messages.

- The status LED displays the appropriate color for the following conditions.
  - **Green** - On solid indicates unit is charging.
  - **Amber** - On solid indicates equalizing.
  - **Red** - On solid indicate a fault condition. The fault number is shown on the digital display.

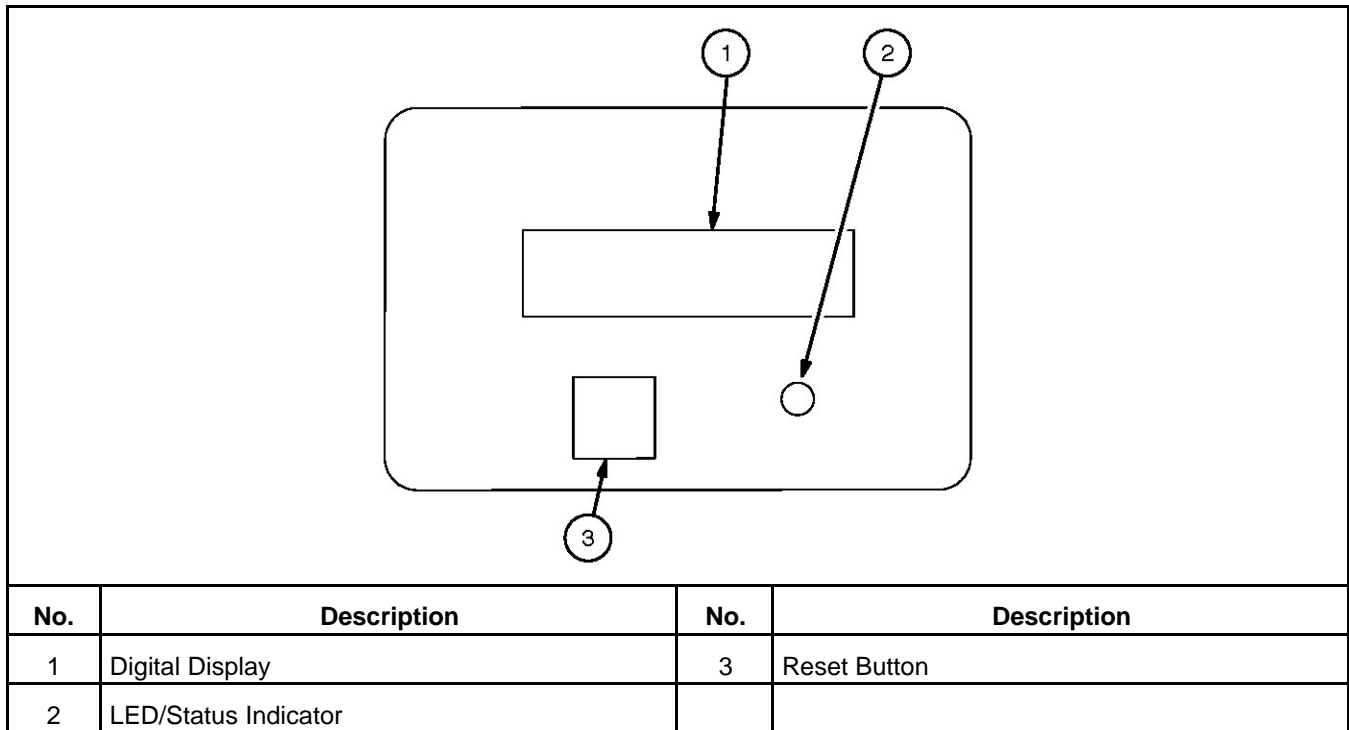

FIGURE 79. CONTROL PANEL

### 8.1.2 Battery Charger Configuration

The **RESET** button on the control panel is used to configure the battery charger. More information on the Setup menus is included in the Battery Charger Operator Manual (901-0107).

- **Battery Voltage and Type** - The battery charger must be correctly configured, using the Setup menus, for the correct battery voltage and type before it is connected to the battery. The battery voltage can be set for 12 or 24 VDC (default = 12 VDC). The battery type can be set for Lead-Acid, Gel, or AGM batteries (default = Lead-Acid).

**NOTICE**

**A factory installed battery charger is set up for the proper DC battery voltage requested on the production order, with the Lead-Acid battery type selected as the default.**

- **Float Voltage** - Various float voltages can be configured using the Setup menus. Consult your battery datasheet for the best possible choice.
- **Battery Equalization** - Battery equalization is available for Lead-Acid batteries that are completely charged, using the Equalize Battery screen in the Setup menus. When battery equalization is in process, the LED status indicator turns amber.

### 8.1.3 Battery Temperature Sensor

A connector for the battery temperature sensor option is located on the front of the battery charger. When used to monitor battery temperature, this sensor is connected from the battery charger to the positive terminal of the battery. A fault message (fault code 2263) is displayed if the battery temperature is too high (reaches 55 °C [131 °F]).

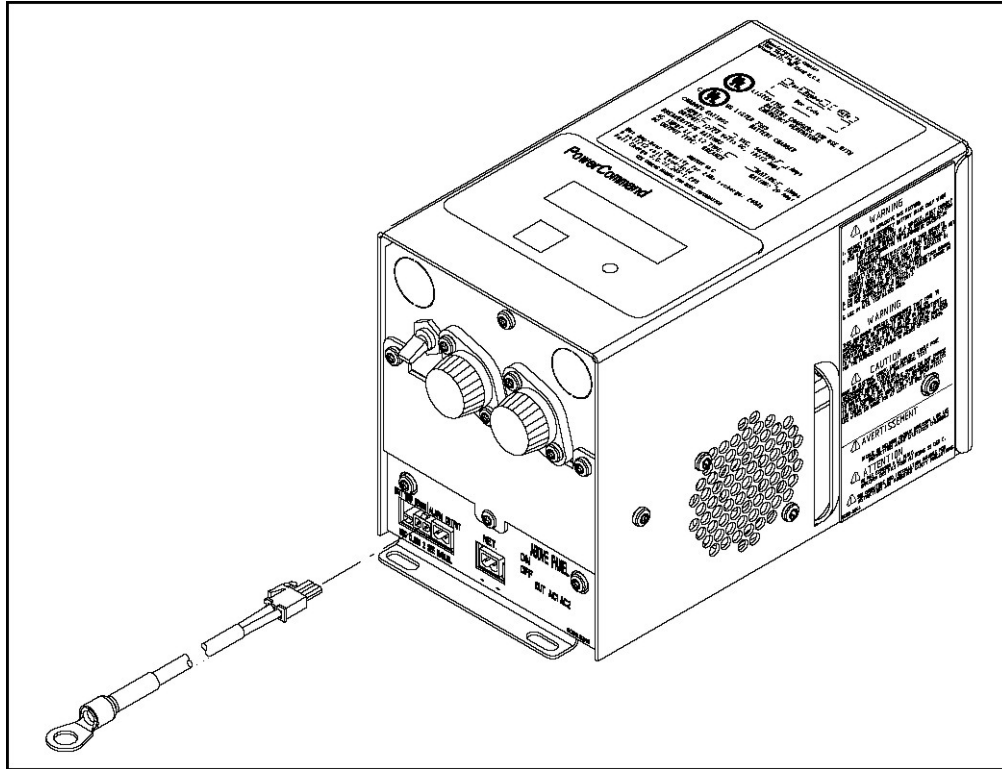

FIGURE 80. TEMPERATURE SENSOR

## 8.2 Battery Circuits

For generator set specific information, refer to the drawings and circuit diagrams provided with your generator set.

# 9 Manufacturing Facilities

<b>U.S. and CANADA</b>	<b>EMEA, CIS</b>	<b>EMEA, CIS</b>
Cummins Inc. 1400 73rd Ave. NE Minneapolis, MN 55432 USA	Cummins Inc. Columbus Avenue Manston Park Manston, Ramsgate Kent CT12 5BF United Kingdom	Cummins Inc. Royal Oak Way South Daventry Northamptonshire NN11 8NU United Kingdom
Toll Free 1-800-CUMMINS™ (1-800-286-6467) Phone +1 763-574-5000 Fax +1 763-574-5298	Phone +44 1843 255000 Fax +44 1843 255902	Phone +44 1327 88-6453 Fax +44 1327 88-6125
<b>BRAZIL</b>	<b>CHINA</b>	<b>INDIA</b>
Rua Jati, 310, Cumbica Guarulhos, SP 07180-900 CNPJ: 43.2201.151/0001-10 Brazil	Cummins Inc. No.118 South Quanli Road , Wuhan Economic& Technological Development Zone , Hubei, P.R.China 430058	Cummins Inc. Plot No B-2, SEZ Industrial Area, Village-Nandal & Surwadi, Taluka- Phaltan Dist- Satara, Maharashtra 415523 India
Phone 0800 286 6467	Phone + 86 (27) 8421 4008 Fax + 86 (27) 8421 4804	Phone +91 021 66305514
<b>LATIN AMERICA</b>	<b>MEXICO</b>	<b>ASIA PACIFIC</b>
3350 Southwest 148th Ave. Suite 205 Miramar, FL 33027 USA	Eje 122 No. 200 Zona Industrial San Luis Potosi, S.L.P. 78395 Mexico	Cummins Sales and Service Singapore Pte Ltd 85 Tuas South Avenue 1 Singapore 637419
Phone +1 954 431 551 Fax +1 954 433 5797	Phone +52 444 870 6700 Fax +52 444 824 0082	Fax +65 6265 6909

This page is intentionally blank.



[power.cummins.com](http://power.cummins.com)

Copyright © 2019 Cummins Inc. All rights reserved.

Cummins, the "C" logo, PowerCommand, AmpSentry, and InPower are trademarks of Cummins Inc.

Other company, product, or service names may be trademarks or service marks of others.

Specifications are subject to change without notice.

